

Universal Safety Controller HUB™

“Control reliable” Category 4 safety center replaces multiple safety relays/modules and seamlessly integrates many safety devices, outputs and control logic functions.

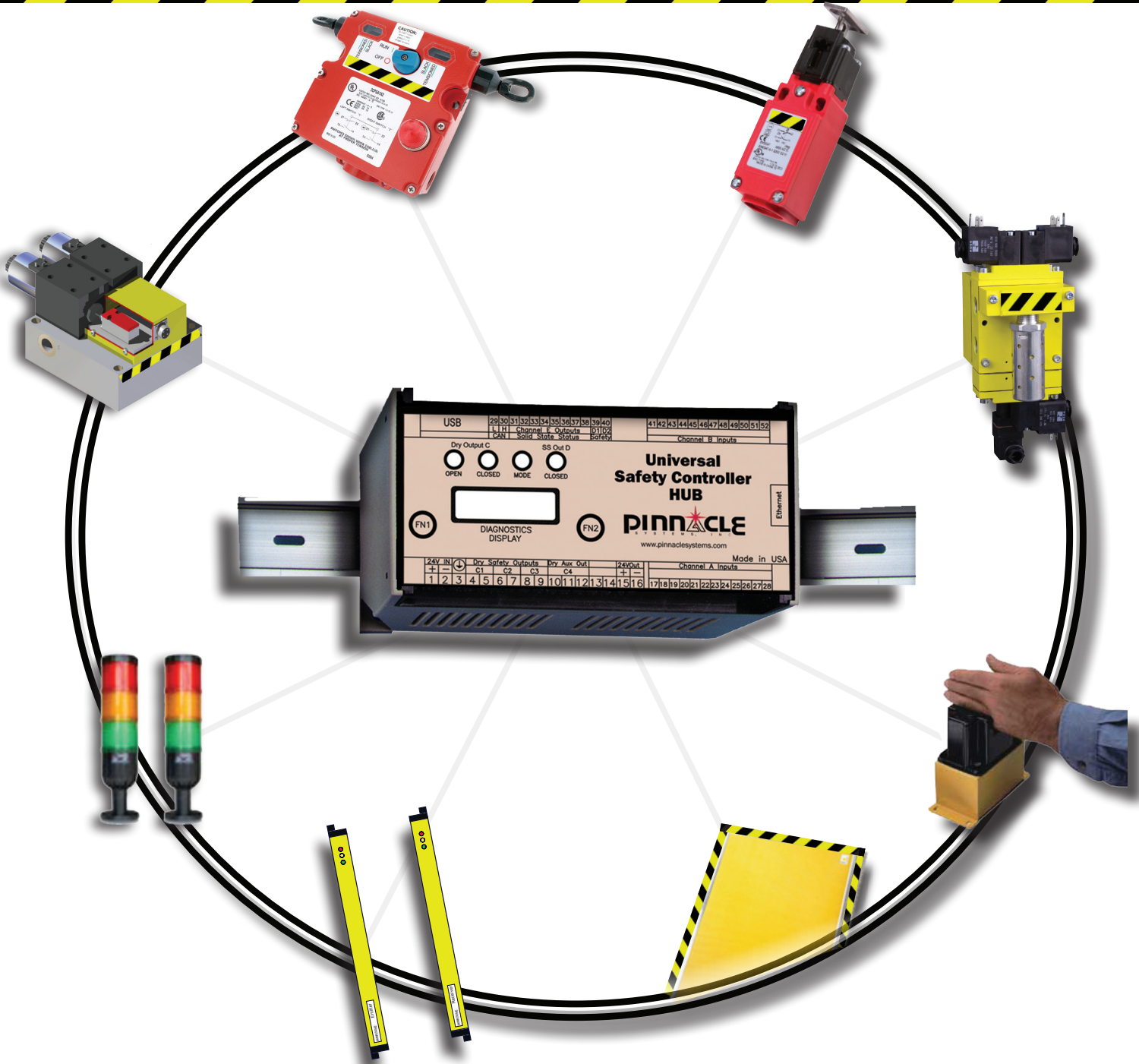

Installation Manual

Manual Revision History				
Revision Number	Revision Date	Authorized Name	Description	Filename
1.0		DK	Creation of New Manual	25-151R0_Universal_Safety_Hub_Manual.PDF
1.1	7/9/2009	DK	Page 2: Item 3 Page 3: Addition of Foot Pedal and Complimentary Input Devices Page 6: lwwc rev and Example rev	25-151R1.1_Universal_Safety_Hub_Manual.PDF
1.2	8/19/2009	DK	Page 7: Rev 28-154 Diagram Page 8: Rev 28-154-2 Diagram	25-151R1.2_Universal_Safety_Hub_Manual.PDF
1.3	4/1/2010	DK	Cover: Updated Art Page 2: Updated Inputs Page 3: Updated Outputs Page 11: Added How to use the Diagnostics Display Page 12: Added #xx has activated display Page 16: Relocated Programming Update	25-151R1.3_Universal_Safety_Hub_Manual.PDF
1.4	9/29/2010	DK	Page 5: Addition of Determining Safety Level EN-954-1	25-151R1.4_Universal_Safety_Hub_Manual.PDF
1.5	10/4/2011	DK	Page 2: Added a Note and rows 20-23 Page 7: Revised Programming / Ordering page, added Input and Output Device Types Charts Pages 8 and 9: Revised Charts	25-151R1.5_Universal_Safety_Hub_Manual.PDF



Universal Safety Controller HUB™

Pinnacle Systems, Inc.
3715 Swenson Avenue
St. Charles, IL 60174
P/N: 28-151R1.5

Customer Service: 630-443-8542 (CST)
(Please have Model #, Serial #, and Software Rev # Available)

Sales and Marketing: 800-569-7697 (EST)

Proper Usage and Limitations

The information disclosed herein includes proprietary rights of the manufacturer. Neither this document nor the information disclosed herein shall be reproduced or transferred to other documents, used or disclosed to others for manufacturing purposes, or for any other purposes, except as specifically authorized in writing by the manufacturer. If this manual is supplied in connection with the sale or delivery of manufacturer's equipment, it is to be used solely for maintenance, repair, or installation of such equipment. The Universal Safety Controller HUB has manufactured in the United States. The Installation Manual was printed in the United States.

You must read and fully understand the following information pertaining to the proper use and limitations of your Universal Safety Controller HUB:

- The Universal Safety Controller HUB must be installed by qualified personnel only.
- The Universal Safety Controller HUB must NOT be used on full revolution presses or any machine that cannot be commanded to stop at any time.
- You must NOT wire the Safety Output contacts of the Universal Safety Controller HUB to an external relay unless you use the External Relay Checking feature.
- The mechanical power press on which the Universal Safety Controller HUB is installed must meet ANSI B11.1-1988 and OSHA 1910.217 regulations. These include inspection and maintenance procedures that must be followed to comply with the regulations. The manufacturer will NOT take responsibility for improperly maintained machinery.
- Point of operation safeguarding is defined in ANSI B11.19-2003. This regulation is used to determine a safe distance to place your Universal Safety Controller HUB. The manufacturer takes no responsibility for injury as a result of improper safeguarding or improper safe distances.
- The Universal Safety Controller HUB may not be able to safely stop a press which has a faulty stopping mechanism. The manufacturer cannot be held responsible for an improperly maintained or faulty stopping mechanism.
- The Universal Safety Controller HUB must be checked before put into operation. Follow instructions provided in this manual for procedures on how to do this.
- The Universal Safety Controller HUB should never be modified or repaired except by qualified personnel and upon authorization of the manufacturer. Never operate machinery that is not in full working order.

- Make sure that all maintenance people, machine operators, die-setters, foreman, and supervisors have read and understood this manual and all procedures have been and will be followed.
- All procedures in this manual must be followed. The manufacturer cannot take responsibility for operation if all procedures and warnings in this manual are not followed.

Warranty

Manufacturer warrants that this product will be free from defects in material and workmanship for a period of two years from the date of shipment thereof. Within the warranty period, the manufacturer will repair or replace (at our discretion) any product that is disclosed as defective upon examination by the manufacturer and is returned with shipping charges prepaid. This warranty will not apply to any product that has been subjected to misuse, negligence, accident, restriction, and use not in accordance with manufacturer's instructions or which will have been altered or repaired by persons other than the authorized agent or employees of the manufacturer.

Disclaimer

The provisions of the warranty are the sole obligations of the manufacturer and exclude all other warranties of merchantability, expressed or implied. Further, there are no warranties that extend beyond the above warranty.

Limitation of Liability

In the event of any claim for breach of any obligations of the manufacturer under any order, whether expressed or implied, and particularly in the event of any claim of a breach of the warranty or warranties contained in the paragraph "Warranty" or of any other warranties, expressed or implied which might despite the paragraph entitled "Disclaimer," be determined to be incorporated in any order, the company shall under no circumstances be liable for any consequential or special damages, either in law or in equity, or for losses or expenses or claims for the same arising from the use of, or inability to use, the products of the manufacturer for any purpose whatsoever.

We have designed our equipment to the very highest performance and safety standards known to the current technological state of the art. However, the installation, usage, suitability, and fitness of our equipment for any purpose, known or unknown, is interdependent upon the performance of other equipment not manufactured, installed, or secured or maintained by the manufacturer. We cannot and do not accept responsibility for any overall system performance when factors, such as these, are beyond our control.

Table of Contents

Introduction.....	1
The System	1
Safety Features	1
Specifications	1
INPUTS (Channels A,B) Device List.....	2
OUTPUTS (Channels C,D,E) Device List.....	3
Input Devices.....	4
Determining Safety Level EN-954-1	5
Output Devices.....	5
Programming / Ordering.....	7
Wiring Diagrams	8-9
Control Dimensions	10
Installation Procedure.....	11
Operation.....	11
How to use the Diagnostics Display	11
Diagnostics Display	12
Troubleshooting.....	13
Fault Codes	13-15
Programming Update Procedure.....	16
Warranty	18
Disclaimer.....	18
Limitation of Liability	18

Introduction

The Pinnacle Universal Safety Controller HUB (HUB) is a control-reliable safety device that provides a convenient way to run all safety and non-safety devices back to a single point. The HUB combines 24 optically coupled Inputs, 8 optically coupled solid-state Outputs for status, 2 Safety Relays with 3 N.O. (held closed) Dry Outputs, and 2 Safety solid-state N.O. (held closed) Outputs. Control-Reliability is achieved by using redundant Input and Output chains along with redundant CPU's, but running different software to cross check each other. Safety Outputs are controlled via hardware watchdog timers as well as both CPU's, allowing either CPU to shut down the Safety relays if a fault occurs.

The System

The Universal Safety Controller HUB (HUB) is a Din-Rail mountable controller unit capable of being expanded (via the CAN data network option) and monitored (via Ethernet option). The HUB Din-Rail controller is 24vdc powered and self contained with its own mechanical Safety Relays, optically coupled inputs & outputs, function buttons for control, and 2 line x 16 character Diagnostics display.

Safety Features

Two mechanical Safety Relays provide up to 3 dry N.O. (held closed) ESTOP circuit outputs with 8A ratings. 2 Solid-State opto relays provide 2 +24vdc N.O. (held closed) ESTOP circuit outputs with 1/2A ratings with automatic resetting fuses that can drive 2 external Safety relays (with external relay monitoring EDM).

Specifications

Input Power

24vdc +/- 20% (7watts max)

Fuse

Input: F1 1A slow-blo nano fuse

Output Channel D F2, F3 1/2A resetable

Relay Outputs

Channel C: PN# 32-098 3 pole 8A contact rating

Channel D: 1/2A Solid State opto with resetable fuse (1A SS opto optional)

Status Outputs

Channel E: 1/2A Solid State resetable fuse (1A SS opto optional)

Channel C4: 5A @250vac dry contact (status for Channel C1-3)

Indicators

Diagnostics Display: 18-010 2 line x 16 character backlit LCD

Channel C: Open (RED), Closed (GRN)

Channel D: Closed (GRN)

Mode: ON (Yel)

Construction & Dimensions

Din-Rail mountable polycarbonate housing providing IP40 protection, UL94V-1

Internal RF shielding (nickel paint)

5.87" L x 2.95" W x 4.33", 35.5mm (1.4") din-rail mounting

Environmental

0 to 50°C (up to 95% humidity, non-condensing)

Response Time

Note: Response time of the Universal Safety Controller HUB (HUB) does not include response time of your devices signalling this HUB.

Fault detection: 500uSec

Input device detection (open/closed): 500uSec per device

Channel C: 5mSec open time

Channel D: <1mSec open time

INPUTS (Channels A,B) Device List

Note:

--All STOP devices default as N.C./N.C. Select complimentary N.C./N.O. logic by adding the letter B after the Device#

--All RUN devices default as N.O./N.O. Select complimentary N.C./N.O. logic by adding the letter B after the Device#

--All devices default as SOURCING (+24v inputs). Select SINKING (ground inputs) by adding the letter G before the Device# for SINKING 1 input, or after the Device# for both.

--Mute-Out devices default as complimentary inputs (see page 4 for instructions).

--Specify optional Timer function to allow time limits by adding T to the device #

1)	2 Wire	RUN/STOP Device	Dual Channel	Signaling device used to START or STOP operation. This device# will not fault the Safety Hub if the 2 signals differ from each other.
2)	2 Wire	Light Curtain	Dual Channel	Light Curtain or ESTOP used to STOP operation. Blocking the Curtain will require a restart of any RUN device
3)	2 Wire	Foot Pedal	Dual Channel	Foot pedal used as RUN device. Opening of any Safety Device will require you to release/reapply Foot.
4)	3 WireP	ESTOP	Dual Channel	2 N.C circuit ESTOP device which gets 1 pulsed 24vdc signal from the Safety Hub.
5)	reserved			
6)	4 WireP	ESTOP	Dual Channel	2 N.C. circuit ESTOP device which gets 2 pulsed 24vdc signals from the Safety Hub.
7)	2 Wire	Palm Buttons	Dual Channel	2 Hand No Tie Down (THNTD) RUN control function for a set of Palms. (Note: You can have multiple Palm Button Stations).
8)	4 Wire	Safety Mat	Dual Channel	4-wire Safety Mat STOP function. Special jumper settings (always uses A27-28, B51-52)
9)	2 Wire	Limit Switch	Dual Channel	Mechanical Limit or Pressure Switch function.
10)	2 Wire	RST Button	Channel C	Resets a latched Channel C output (if you do not want a automatically resetting Channel C output)
11)	2 Wire	RST Button	Channel D	Resets a latched Channel D output (if you do not want a automatically resetting Channel C output)
12)	2 Wire	CI		Channel C Cincinnati Interface
13)	2 Wire	CI		Channel D Cincinnati Interface
14)	2 Wire	Mute-Out	Channel C	Dual circuit Mute-out (each input must be in opposite states)
15)	2 Wire	Mute-Out	Channel D	Dual circuit Mute-out (each input must be in opposite states)
16)	2 Wire		EDM	Channel C External Device monitor input
17)	2 Wire		EDM	Channel D External Device monitor input
20)	2 Wire	By-Pass	Dual Channel	Key Switch By-Pass (used to bypass other devices)
21)	2 Wire	Prox Sensor	Dual Channel	Prox Sensor Input (1/4" pinch point)
22)	2 Wire	Mute-Out	Dual Channel	Mute-Out bypass for Foot Switch 3
23)	4 Wire	Palm Buttons	Dual Channel	2 Hand No Tie Down (THNTD) RUN control function for a set of Palms (uses N.O. & N.C. contacts)

OUTPUTS (Channels C,D,E) Device List

0)	No Output Device Selected		
1-8)	Channel E1-8	Solid State opto Relays (8)	Provides 8 +24vdc outputs (NOT monitored). 1/2A@24vdc resistive load (optional 1A@24vdc). (E1 is always used as a status indicator for Channel D1-2 [E1 active when D1/D2 active])
16)	Channel C	Mechanical Safety relays	For any Device to control C output. C1, C2, C3 are mechanically linked.
32)	Channel D	Solid-State Safety relays	For any Device to control D output. D1, D2 require EDM option if linked to external mechanical relays.
64)	Channel C4-6	on 2 nd Safety Hub	Channel C Safety Outputs found on 2 nd Safety Hub
128)	Channel D3-4	on 2 nd Safety Hub	Channel D Solid-State Safety outputs found on 2 nd Safety Hub
240)	Channel C	Timer ON	Timer function used to hold Output C ON
241)	Channel C	Timer OFF	Timer function used to hold Output C OFF
242)	Channel D	Timer ON	Timer function used to hold Output D ON
243)	Channel D	Timer OFF	Timer function used to hold Output D OFF
251)	Channel C/D		For Run Devices to Latch output C ON, D OFF
252)	Channel C/D		For RUN or Limit Switch devices Latch output D ON, and C OFF.
253)	Channel C/D		For RUN or Limit Switch devices to shut down both C and D outputs.
254)	Channel C/D		For ESTOP Devices to Control both C & D outputs
255)			Faults all Outputs (shuts down) when this Device OPENS.

Input Devices

Safety Devices must always have dual stop circuits in either 2,3 or 4 wire format. These devices must drive Channel C or Channel D. Channel C & D are Monitored Safety Outputs (Channel E is not a monitored). The Installer must determine which wire format meets the safety category required for the job.

- Solid-State Output Safety Devices that provide 24vdc outputs are 2 wire devices.
- Dry Contact Safety Devices that do NOT provide 24vdc outputs are 2, 3 or 4 wire devices depending on Safety Category Level.

Input Sourcing (default) / Sinking. By default all inputs are Sourcing (require +24vdc to close). All inputs can be sinking or sourcing by configuring internal Jumpers within the Universal Safety Controller HUB. Both 3 and 4 Wire Input Types can only be Sourcing.

Internal Jumpers JA1-JA12 and JB1-JB12:

Pins 1-2 = Sinking (GND) input

Pins 2-3 = Sourcing (+24vdc) input

(see diagram for location of jumpers)

Input Wire Types.

- The 4 wire system meets the highest Safety Level (Category 4). This is achieved by providing the Safety Device with Dual pulsed 24vdc signals. This enables the HUB to check for shorts between the Dual Channels.
- The 3 Wire system saves a Terminal, but still provides a pulsed 24vdc signal to the passive Safety Device.
- The 2 Wire (pulsed input) system requires the Safety Device to pulse its output as a check for shorts between Dual Channels.
- The 2 Wire (standard) system requires the Safety Device to check itself for shorts between the Dual channels.

(see page 4)

Palm Button Station. Software inside the Universal Safety Controller HUB provides the anti-tie-down and concurrent operation checking. When either Button is activated you have 1/4 second to activate the other Button. When 1 Button is released, the other is required to be released to re-activate. Standard Inputs activate when both Channels close. Optionally, Output activates when Channel A closed & Channel B open. Output not active when Channel A open & Channel closed. (see page 4)

MATS / Bumpers / Edges. The last 2 Terminals of Channel A (A27-28) and Channel B (B51-52) can be configured (Internal Jumpers JA21, JA22 & JB13, JB14) for use with 4 Wire Mats, Bumpers, Edges. If you have more than 1 of these devices, then all these devices must be wired in series.

- Pins 1-2 = Terminals used as standard inputs
- Pins 2-3 = Terminals are used for Mats, Bumpers, Edges.
(see page 4)
(see diagram for wiring example)

Cincinnati Interface. The Cincinnati Press will cycle inputs every press cycle. When the inputs open, the specific Channel output will also cycle. This is to prove the Safety Outputs can still open and are still being monitored. (See diagram on page 8 for wiring example.)

Mute-Out. Dual Signals must always be in opposite states or a fault will occur. The Universal Safety Controller HUB cannot turn on in a Muted condition or a fault will occur.

Channel	A	B
Guard	closed	open
Mute	open	closed
Fault	open	open
Fault	closed	closed

(see diagram for wiring example)

Foot Pedal. When the Foot Pedal Device is programmed into the HUB, the corresponding Output is controlled by Foot Pedal. When the Foot Pedal is Closed, the Output is closed, unless any safety devices on the same Output are Opened. If any safety device is opened, the Output will remain open even after all the safety devices are once again closed. You must take your foot off of the Foot Pedal to reset the Output. At this point, you may re-engage the Foot Pedal to Close the Output.

Complimentary Input Devices. Any device can be wired into the HUB as a complimentary input device (N.C./N.O.) as opposed to the standard input device (N.C./N.C.). By adding the letter "C" to the device number, the HUB will program the device as a complimentary device. Mute-Out devices are automatically complimentary.

Limit Switch / Pressure Switch Devices. If this device is used as a STOP device, then select a standard output. If this device is used as a Limit switch, then select one of the special outputs that control the C or D outputs used in Press control functioning.

Device Latching. By selection special Output device #'s you can allow a Input Device to latch an output. This is not Relay Latching as described in the Output Section.

Determining Safety Level EN954-1

Category Level will determine the type of E-Stop Circuit(s) used.

- Category #2 2 Wire
- Category #3 3 Wire
- Category #4 4 Wire

Solid-State Output Light Curtains can use the 2 Wire configuration in a Category #4 installation as long as the Light Curtains Outputs are Self-Checking. (The Microguard Model SS Light Curtain has Self-Checking Outputs)

S1	Severity of injury – Slight (i.e. cut or bruise)
S2	Severity of injury – Serious (i.e. hospital treatment to fatal)
F1	Frequency of exposure to hazard – seldom or often but short exposure
F2	Frequency of exposure to hazard – continuous or frequent with long exposure
P1	Possibility of avoiding hazard – possible or slow moving hazard
P2	Possibility of avoiding hazard – not possible or fast moving hazard
⊗	Possible category requiring further measures
☑	Preferred category
☑☑	Measures exceeding requirements for risk involved

Output Devices

Channel C1-3 and Channel D1&2 are the only Safety Output Devices.

Latching Relay Output. To force a Safety Output Channel to latch upon opening of any Safety device, you must add a RST Button device. To then Reset a Safety Output Channel, you must cycle the RST Button (see diagram for wiring example).

External Device Monitoring (EDM). EDM is required if you want to add external mechanical Safety Relays to either Channel C or Channel D. Most likely EDM will find use with Channel D, since Channel C already has monitored Safety Relays built in.

EDM is wired in series through N.C. Contacts of both external Safety Relays. EDM inputs should be closed when the output is OFF (open). The EDM inputs should be open when the Output is ON (closed). (see diagram for wiring example)

Status Outputs. Solid-State Channel E outputs 1-8 provide non-safety status. Channel E1 is always indicating the Status of Output Channel D. (E1 on = Channel D on). The remaining 7 outputs can be tied to any particular Input Device. The Auxiliary Dry contact Channel C4 output can be used as a status Channel C.

Auxiliary Channel C4 Dry Relay Contact. A non-monitored form C N.O. & N.C. dry 5A relay contact is provided as Channel C4 and can be used to indicate status of the Channel C outputs.

Timers. Use a Timer to hold an output On or Off for a user programmable amount of time. See Page 11of18 for Timer programming.

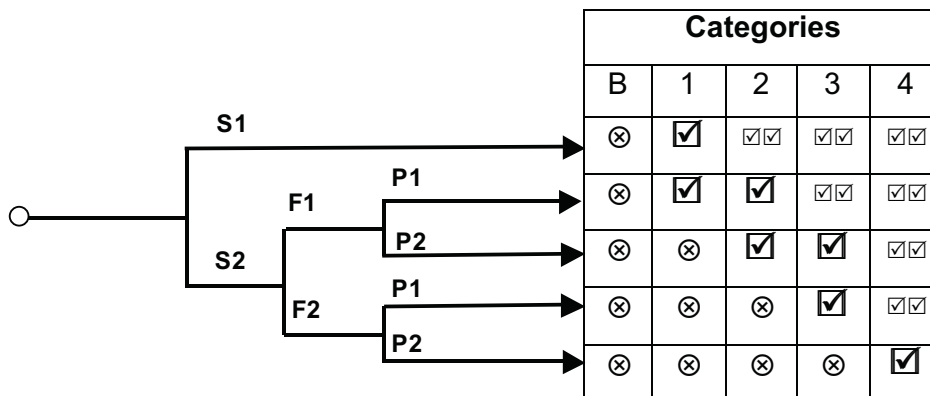

Programming / Ordering

The Universal Safety Controller Hub is programmed by the factory, but can be modified in the field by contacting the factory (via email). (see page 16)

Terminals fill out terminals started from the left side (A17 and B41) and work right (except for mats which always use A27/28 & B51/52)

A Hub Model# is composed of a list of device and there functions. Page 8 illustrates an example of a common safety guarding application. Page 9 illustrates an example of a sophisticated press control application (that also includes guarding).

For more sophisticated applications, email the factory with a full description of each device required and its function (what does it control and when). The factory will convert this into a Model#

The full Model# format can include not only the device# but the output you wish to control.

Ordering/Pricing Procedure

Format Model#: SH-XX(YY)-XX(YY)-XX(YY)- ...
(where XX is the Input device type, where YY is an OPTIONAL Output device type)

Example Model#: SH-2-2-6-10-2-2D-6D-8C
(2 light curtains + 1 ESTOP tied to C with latching RESET, 1 light curtain + mat tied to C with no latching, 1 light curtain + 1 ESTOP tied to D with no latching)

Current List of Input Device Types

XX	Terminals used	Input Device Type
1(T)	2	START or STOP or CANCEL button inputs
2	2	CAT 4 Light curtain or CAT 2 ESTOP
3	2	Foot Pedal
4	3	Cat 3 ESTOP input
5		Reserved
6	4	Cat 4 ESTOP input
7(T)	2	Palm button station (2 palm buttons) N.O. from each button
8	4	NSD Safety Mat or any 4-wire pressure sensor device
9(T)	2	Limit Switch (mechanical or Pressure)
10(T)	2	Reset Button for Channel C
11(T)	2	Reset Button for Channel D
12(T)	2	Cincinnati Interface for Channel C
13(T)	2	Cincinnati Interface for Channel D
14(T)	2	Mute-Out bypass for Channel C
15(T)	2	Mute-Out bypass for Channel D
16(T)	2	EDM (External Device Monitor) for Channel C
17(T)	2	EDM (External Device Monitor) for Channel D
18		Reserved
19		Reserved
20(T)	2	Key Switch bypass (used to bypass other devices)
21(T)	2	Prox sensor input (1/4" pinch point)
22(T)	2	Mute-Out bypass for Foot Switch device #3
23(T)	4	Palm button station (2 palm buttons) N.O. and N.C. from each button

Current List of Output Device Types

YY	Channel output	Output Device Type
	C	Assume Devices use Channel C if left blank Assume Device Status tied to each Channel E output
E	E	Device Status Output (default)
C	C	Devices tie to Channel C mechanical relays
D	D	Devices tie to Channel D solid state relays
240C	C	Timer function to hold Channel C ON
241C	C	Timer function to hold Channel C OFF
242D	D	Timer function to hold Channel D ON
243D	D	Timer function to hold Channel D OFF
251CD	C/D	Devices Latch C ON and D OFF
252CD	C/D	Devices Latch D ON and C OFF
253CD	C/D	Devices Latch both C & D OFF
254CD	C/D	ESTOP devices turn C & D OFF both
255CD	C/D	Devices turn C & D OFF both

Universal Safety Hub

MUTE-OUT: only bypasses the light curtain

SH-2-14-6-6-23D

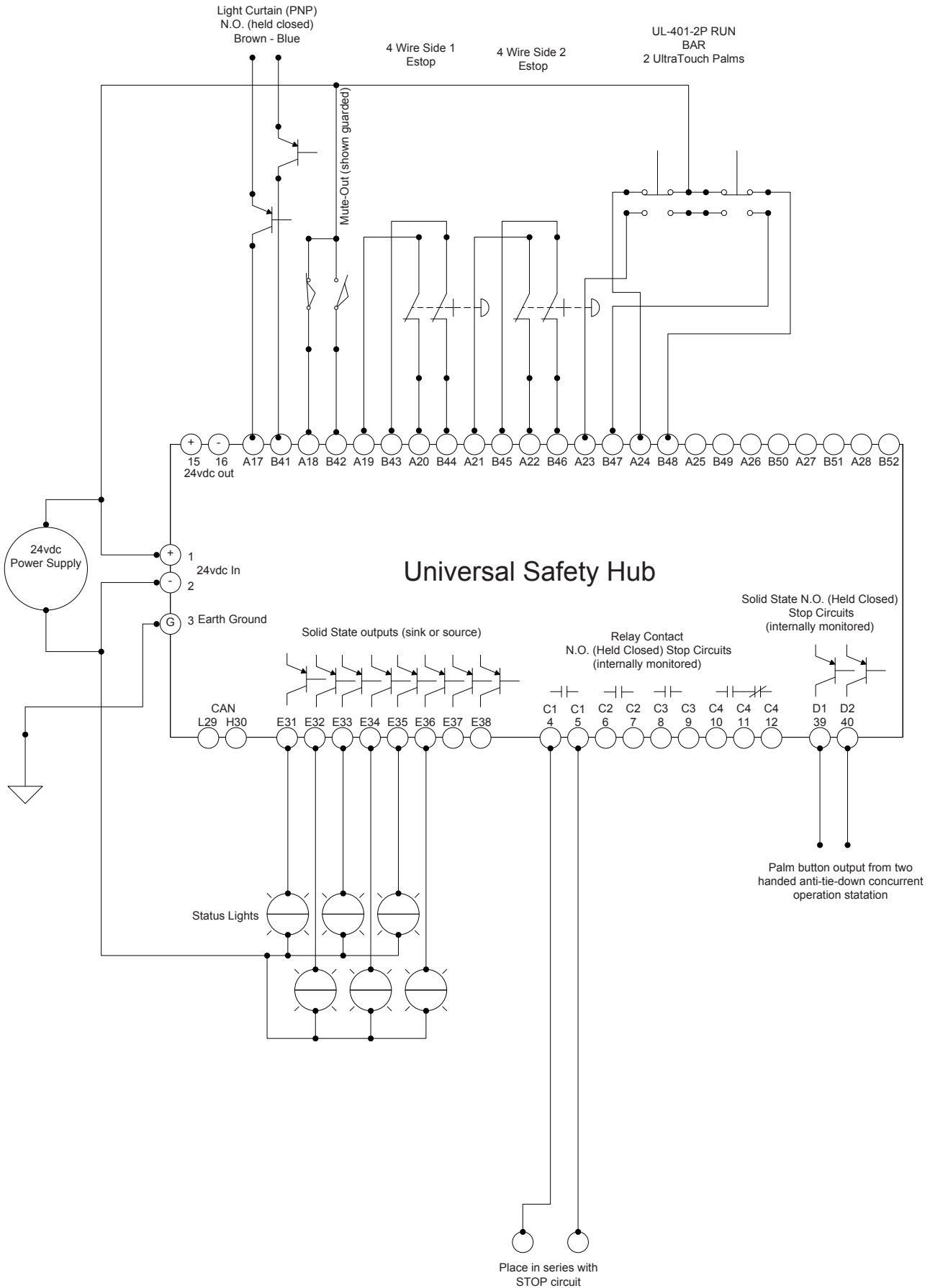

Universal Safety Hub

Model# SH-23(251)-2(254)-6(254)-2(250,3)-9(252,2)-9(253,2)-17(32)

Internal Jumper:
 JA1-JA12: Bottom 2 pins each
 JB1-JB12: Bottom 2 pins each
 Except JB7 = Top 2 pins

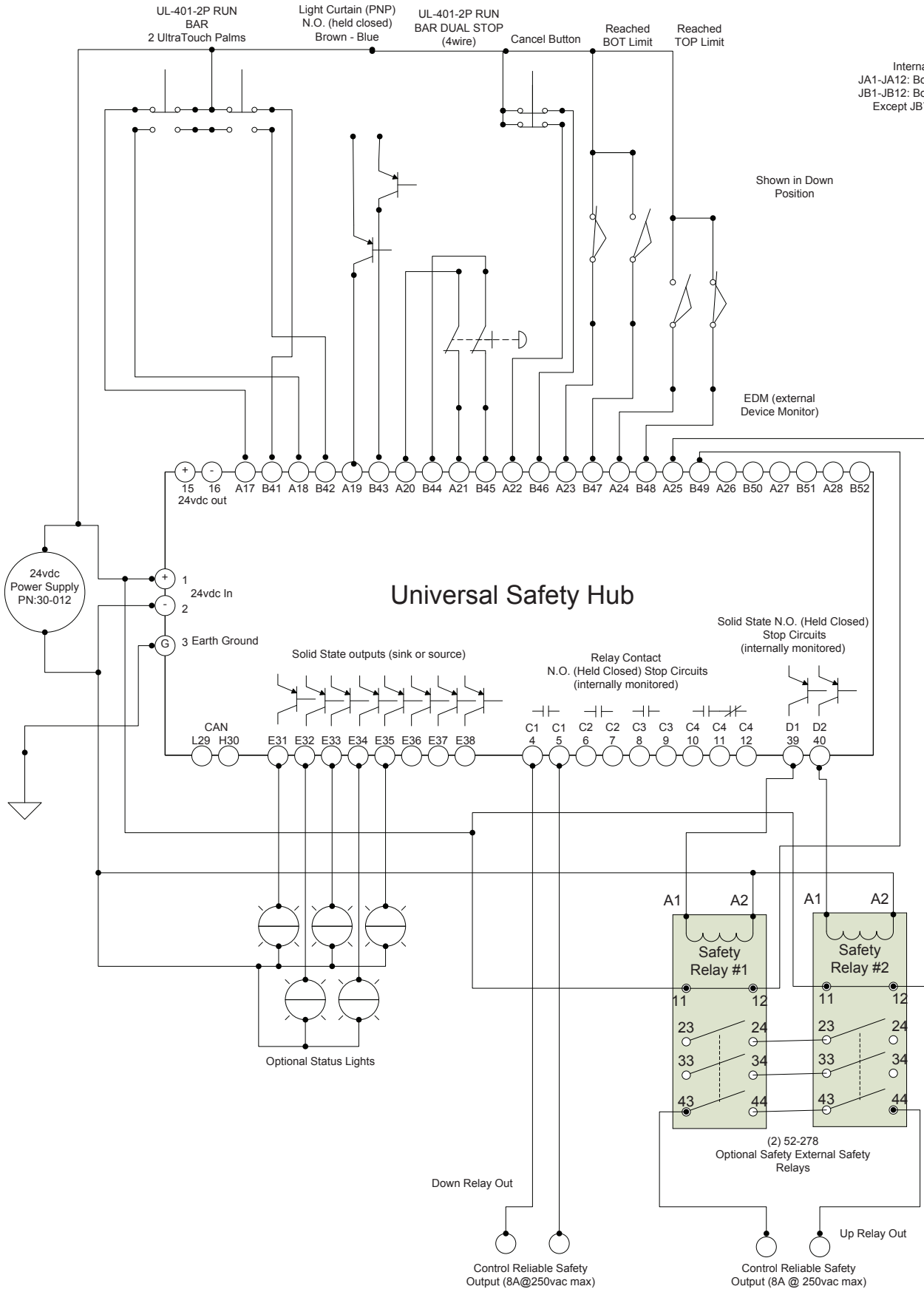

Control Dimensions

The Controller Module can be either Din-Rail mounted or screwed down. Be sure to allow space for wiring to top of box (both sides).

Enclosure: Gray polycarbonate with clear cover. Provides IP40, UL94V-1

Enclosure Dimensions: 5.87" (149 mm) length x 4.33" (110 mm) depth x 2.95" (75 mm) height.

Enclosure Mounting: 35mm DIN-rail mountable or Mounting screws on corners of enclosure requiring two combo-head screws (3.5 x 0.6mm x 14 mm or #6 x .5).

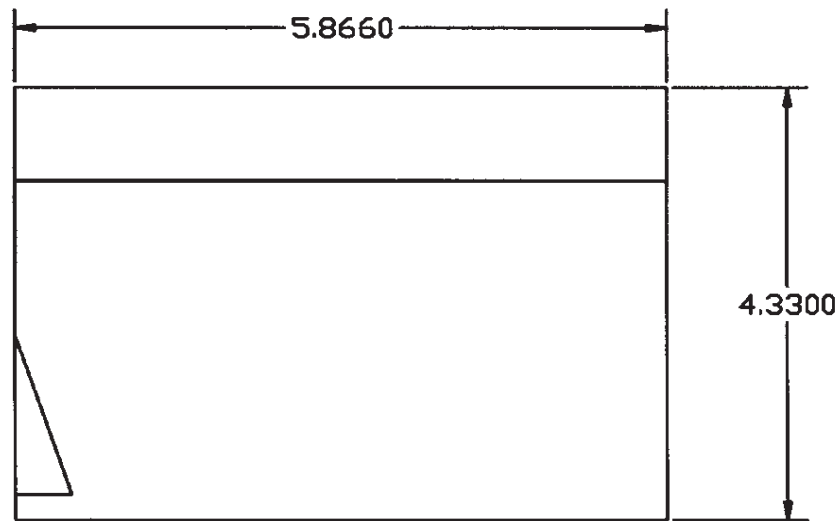

Front View

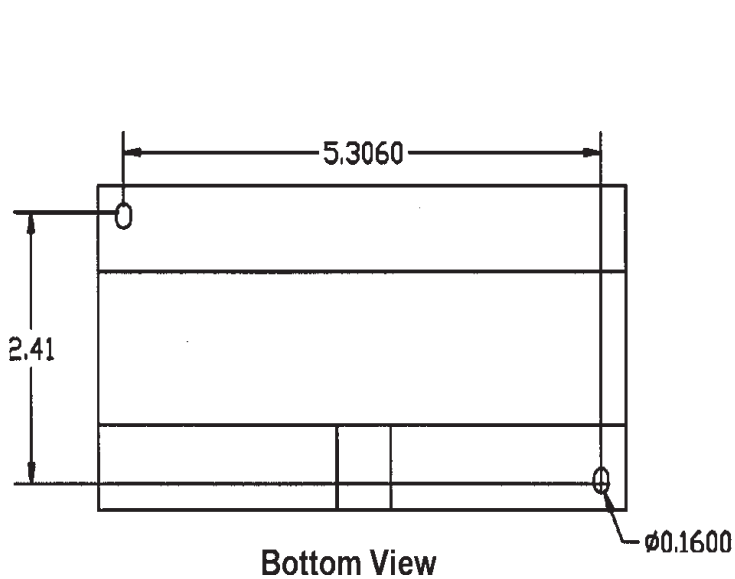

Bottom View

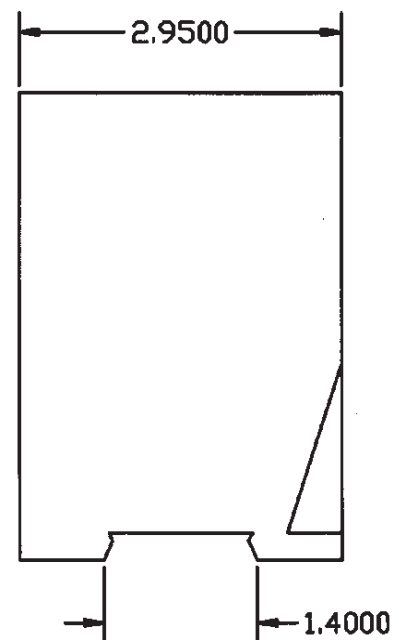

Side View

Note: The Universal Safety Controller HUB should be examined on a daily basis for correct operation. Malfunctioning units should be removed from further operation.

How to use the Diagnostics Display

Operational Status: Shows current status of all devices, showing the first device found that is opposite its NORMAL status.

(Press FN1 one time)

Terminal Status: Shows status of each Terminal on both the A and B side of the Safety Hub. 0=open, 1=closed. You cannot see the Terminal status of 3 or 4 wire devices since they are pulsed (Press FN2 to scroll through all Terminals)

(Press FN1 one time)

Device Status: Shows status of each Device as determined by the Master and Slave computers. A=Slave & B=Master. 1=active (Press FN2 to scroll through all Devices)

(Press FN1 one time)

A/D Status: Analog inputs status for Mat devices only (Press FN2 to scroll through all channels of A/D)

(Press FN1 one time to return to Operational Status if no TIMERS are active)

Device Timer Value: Shows current Timer setting if 1/10th of seconds. (Press FN2 to scroll through all timer available)

(PROGRAM MODE: Press FN1 & FN2 together, now FN1 = +, FN2 = -, when finished Press FN1 & FN2 together again)

(Press FN1 one time to return to Operational Status)

Installation Procedure

1. Determine the mounting location for the Universal Safety Controller HUB (HUB). It should be located in a protective panel as far away from electrical noise as possible.
2. Provide a 24vdc power supply with enough capability to power the HUB and any 24v devices you attached to it.
3. Determine the devices that will be wired to the HUB and wire them up to the HUB in the same order as the Model# states. (See page 6 and example wiring pages for additional information.)

Operation

1. Upon power up, the Software Rev# will come up for a short time.
2. The 2 computers (Master & Slave) communicate with each other to check for faults.
3. If no Faults are detected, the Universal Safety Controller HUB will operate as normal.

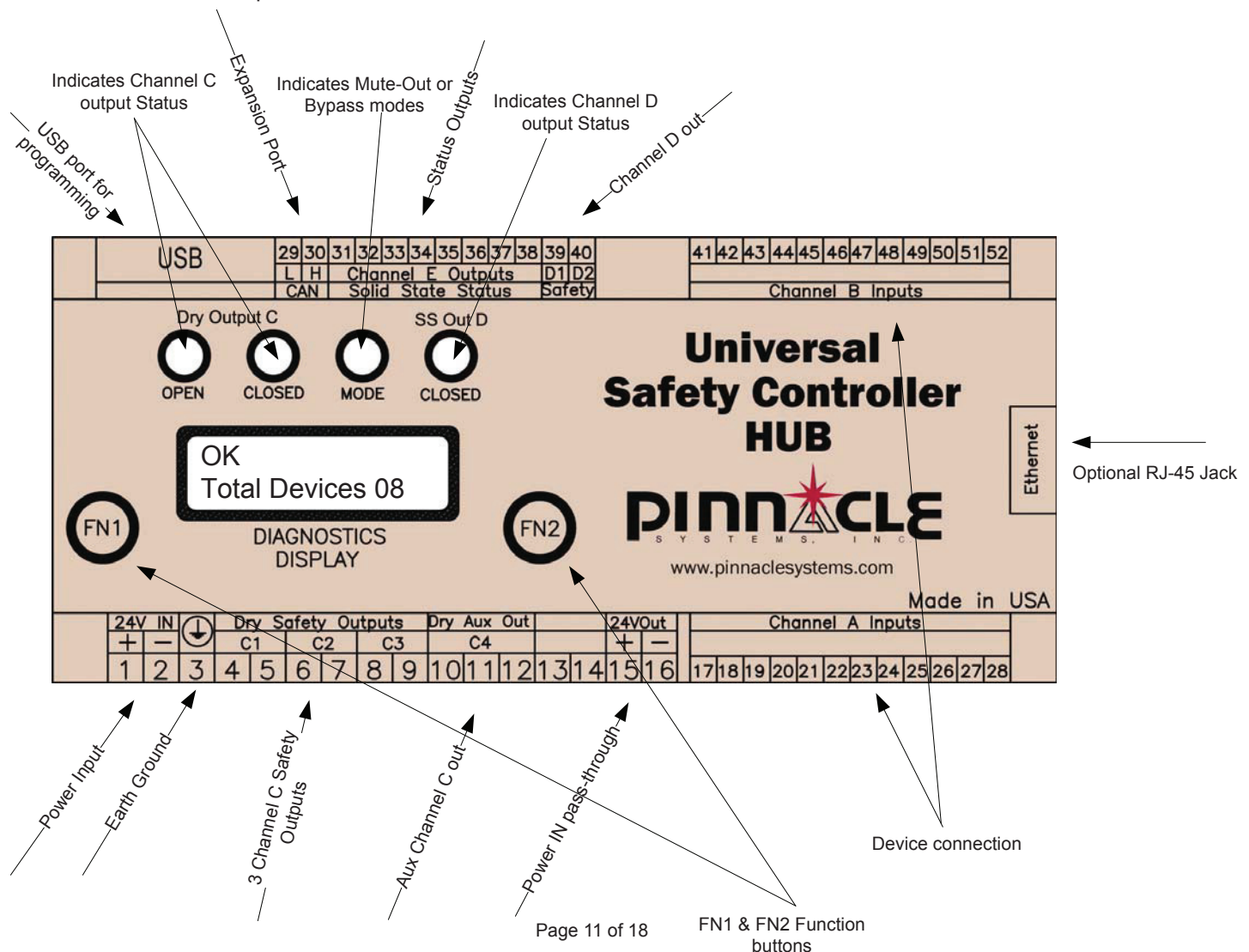

Diagnostics Display

```
OK
Total Devices xx
```

```
OK  ETHERNET
Total Devices xx
```

If all devices attached are in their normal state (i.e. E-Stop devices closed, Palm buttons OFF, Mute-out in guarded condition, reset buttons in OFF) then the Diagnostics Display will read "OK" and show the total number of devices programmed into the HUB. If ETHERNET appears on the display, this indicates that you have the ETHERNET option and someone is currently accessing that particular HUB device.

```
ESTOP-2W DEV#xx
Term#  Ayy - Bzz
```

Indicates 2 wire device #xx has opened up. The Terminal numbers that this device is connected to are shown on the second line.

```
ESTOP-3W DEV#xx
Trm#  Aww Byy Bzz
```

```
ESTOP-3W DEV#xx
Trm#  Aww Ayy Bzz
```

Indicates 3 wire device #xx has opened up. The Terminal numbers that this device is connected to are shown on the second line.

```
ESTOP-4W Dev#xx
T#  Avv-ww Byy-zz
```

Indicates a 4 wire device #xx has opened up. The Terminal numbers that this device is connected to are shown on the second line.

```
On Mat  Dev#xx
T#  Avv-ww Byy-zz
```

Indicates the 4 wire Mat(s) circuit is shorted (on mat) and the Device number. The Terminal numbers that this device is connected to are shown on the second line.

```
Limit SW DEV#xx
Term#  Ayy - Bzz
```

Indicates 2 wire device #xx has activated. The Terminal numbers that this device is connected to are shown on the second line.

```
Mute ON RLY C
Dev#xx T#Ayy-Bzz
```

```
Mute ON RLY D
Dev#xx T#Ayy-Bzz
```

Indicates Mute-Out device for Relay C or D now active (MUTED). The Device# and the Terminal numbers that this device is connected to are shown on the second line.

```
Palms Active
Dev#xx T#Ayy-Bzz
```

Both Palm devices activated together within 1/4 second of each other and held down. The Device number and the Terminal numbers that this device is connected to are shown on the second line.

```
Palm time out
Dev#xx T#Ayy-Bzz
```

Both Palms were NOT activated with 1/4sec of each other. To clear this fault both palms must be released (opened). The Device number and the Terminal numbers that this device is connected to are shown on the second line.

```
RST pushd RLY C
Dev#xx T#Ayy-Bzz
```

```
RST pushd RLY D
Dev#xx T#Ayy-Bzz
```

Latching Relay Reset Button for Relay C or D was pushed (cycled open/closed). To further reset relay outputs, you must clear (open) the device back up). The Device number and the Terminal numbers that this device is connected to are shown on the second line.

```
CI active RLY C
Dev#xx T#Ayy-Bzz
```

```
CI active RLY D
Dev#xx T#Ayy-Bzz
```

Cincinnati Interface device for checking Relay C or D is active (Relay output turned OFF). This Device must open before the Relay output will attempt to turn back on. The Device number and the Terminal numbers that this device is connected to are shown on the second line.

Troubleshooting

The Universal Safety Controller HUB has built in Diagnostics Troubleshooting features found by pushing the FN1 and FN2 buttons.

Diagnostics Screen

Standard Status: (as described on the previous page).

Terminal Status:

```
Terminal Status
A18 = 0, B42 = 0
```

Shows the current open/closed status of each pair of terminals starting with A17-B41 and going up to A28-B52. Pressing the "FN1" 1 time from the "Standard Status screen" activates this mode. Pressing the "FN2" button cycles through the Terminals. NOTE: 3 and 4 wire devices will not show Terminal Status as they receive pulsed signals, you must use Device Status.

Device Status:

```
Device Status
Dev# 01 A=1, B=1
```

Show the current Active/not active status of each Device scanned by the HUB. Pressing the "FN1" button 2 times from the "Standard Status screen" activates this mode. Pressing the "FN2" button cycles through the Device list.

Analog Status:

```
A/D Input #0
A/D Value:1023
```

Shows the analog voltage status (for use with Mats). Input#0 should read over 1000, Input#1 is the Mat and should read between 300-400 OFF the mat and between 0-40 ON the mat., Input#2 should read between 500-600, Input#3-7 should read around 0. Pressing the "FN1" button 3 times from the "Standard Status screen" activates this mode. Pressing the "FN2" button cycles through the Analog channels.

Fault Codes

```
FAULT
(blank 2nd line)
```

Indicates the Master processor is in a Fault condition and waiting for a message from the Slave processor.

```
(blank 1st line)
FAULT
```

Indicates the Master processor is in a Fault condition and received a message from the Slave processor.

```
Mstr/Slv no talk
Serial Failure
```

```
Slv/Mstr no talk
Serial Failure
```

Master processor cannot talk to Slave processor.

Slave processor cannot talk to Master processor.

This HUB contains 2 computers (Master and a Slave).

```
Mstr Inputs 0-7
Too Noisy
```

```
Slv Inputs 0-7
Too Noisy
```

Master indicates noise on inputs B41-48.

Slave indicates noise on inputs A17-24.

Check for bad connection, wrong voltage levels.

```
Mstr Inputs 7-15
Too Noisy
```

```
Slv Inputs 7-15
Too Noisy
```

Master indicates noise on inputs B49-52.

Slave indicates noise on inputs A25-28.

Check for bad connection, wrong voltage levels.

IIC bus failure
Master

IIC bus failure
Slave

Master or Slave internal communications with external devices lost. Could be fault circuits.

A/D Failure
Master

A/D Failure
Slave

Master or Slave analog voltage readings out of specification.

Master Fault
Shut down all

Slave Fault
Shut down all

Master or Slave shut down for unknown reason.

K1 Relay
Not Energizing

K2 Relay
Not Energizing

K1 or K2 Relay Fault condition. Not turning ON when asked to. This is the Safety Relay for Channel C. This could indicate a faulty circuit. K1 is monitored by the Slave, K2 is monitored by the Master.

K1 Relay
Stuck ON (fault)

K2 Relay
Stuck ON (fault)

K1 or K2 Relay Fault condition. Appears as ON, and will not turn OFF. This is the Safety Relay for Channel C. This could indicate a welded relay contact or faulty circuit or fault relay. K1 is monitored by the Slave, K2 is monitored by the Master.

K3 Relay
Not Energizing

K4 Relay
Not Energizing

K3 or K4 Relay Fault condition. Not turning ON when asked to. This is the Safety Opto Relay for Channel D. This could indicate a faulty circuit or the fuse is blown. K3 is monitored by the Slave, K4 is monitored by the Master.

K3 Relay
Stuck ON (fault)

K4 Relay
Stuck ON (fault)

K3 or K4 Relay Fault condition. Appears as ON, and will not turn OFF (voltage appears on the D output). This is the Safety Opto Relay for Channel D. This could indicate a shorted Opto or faulty circuit. K3 is monitored by the Slave, K4 is monitored by the Master.

Mstr On/Slv Off
Dev#xx , Term#yy

Slv On/Mstr Off
Dev#xx, Term#yy

A Device attached to the HUB has faulted out where the Master indicated ON (B channel), but the Slave indicated OFF (A channel), OR the Slave indicated ON (A channel), but the Master indicated OFF (B channel). Check the wiring of your Device# or the output from your device to find the disparity between the A and B channels.

Mstr Off/Slv ON
Dev# ,Term#

Slv Off/Mstr ON
Dev# ,Term#

A Device attached to the HUB has faulted out where the Master indicated OFF (B channel), but the Slave indicated ON (A channel), OR the Slave indicated OFF (A channel), but the Master indicated ON (B channel). Check the wiring of your Device# or the output from your device to find the disparity between the A and B channels.

False volt Fault
Dev# ,Term#

A 3 or 4 wire device# that requires a pulsed 24vdc output from Channel A or B was checked as incorrect. This maybe due to incorrect wiring or the device attached is conflicting with the A or B output of the HUB.

Device # fault
No such Device

Universal Safety Controller HUB was incorrectly programmed or corrupted.

Mstr Mat Fault
above limit

Slv Mat Fault
above limit

Master or Slave Mat circuit detected an incorrect voltage on the Mat terminals. Possibly incorrect wiring or jumper configuration.

EDM K1K2 Fault
On should be Off

EDM K1K2 Fault
Off should be On

External Device Monitoring (external Relay checking) found in wrong condition. Check wiring through external relays (N.C. contacts).

Mute Fault
K1K2 Master

Mute Fault
1K2 Slave

Master or Slave detected that the Mute-out Inputs (for Channel C) were not in opposite states as required. Check your Mute-Out signals and timing of them.

Mute Fault
K3K4 Master

Mute Fault
K3K4 Slave

Master or Slave detected that the Mute-out Inputs (for Channel D) were not in opposite states as required. Check your Mute-Out signals and timing of them.

Programming Update Procedure

Changes to the programming in the field can be done via EMAIL and the USB port on the HUB. The Factory can EMAIL a zip file containing the Master and Slave computer programs for a specific Device setup. Below is a procedure:

1. Email Factory (service@pinnaclesystems.com), following the Programming Model # on the previous page, with the new model# you want the HUB to run.
2. The Factory will EMAIL you back with the Master file SHM.s19 and the Slave file SHS.s19.
3. Attach a standard USB cable between your HUB and PC
4. The “first time” you will need to insert the CD that came with the HUB. This CD contains the Driver for the USB connection. Let your PC search the CD to find the proper Driver.
5. Run “Hyperterminal” that comes with Windows XP, but is also included on the CD if you are running Windows Vista.
6. The “first time” you will need to setup “Hyperterminal”. You need to make sure the USB cable is connected between the PC and the Safety Hub before you run “Hyperterminal”. Set up “Hyperterminal” to connect using the COM port that wasn’t listed before you connected the USB cable to the HUB. Then Select configure and set the bits/second baud of 230400. Save the configuration you just created for use if you need it next time.
7. Turn power ON to the HUB (you have 3 seconds to hit the “SPACE BAR” on the PC keyboard. Otherwise the HUB will power up for normal operation).
8. If you succeeded with step 7), you will see a menu appear on the Terminal window.

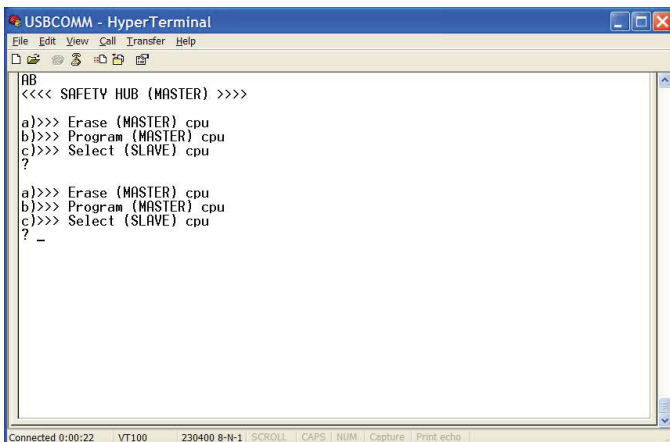

9. Type in ‘a’ to erase, ‘b’ to start to program, then click “Transfer” and click “Send text file”. The file for the Master is shm.s19. Wait until the menu re-appears.

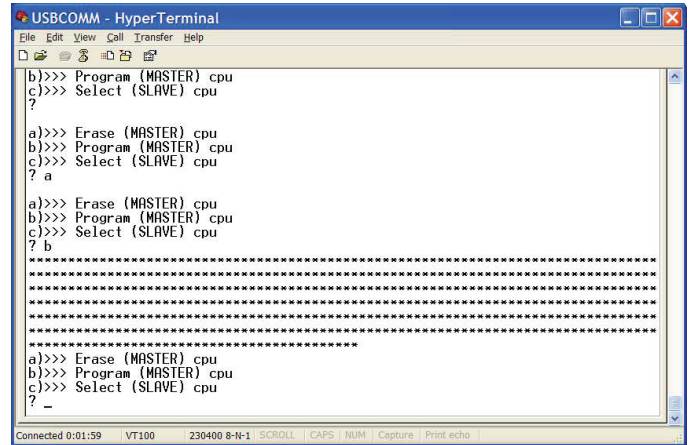

10. Now, Type in ‘c’ to switch to the Slave, ‘d’ to erase, ‘e’ to start to program, then send the text file shs.s19. Wait until the menu re-appears.

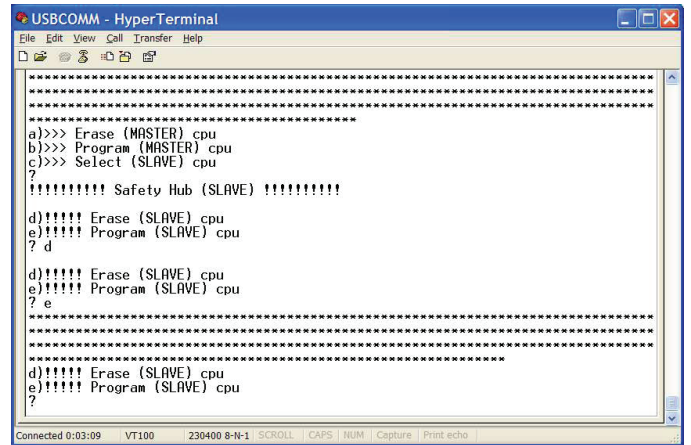

11. Cycle the power and the new configuration will be running.

WARRANTY

Manufacturer warrants that this product will be free from defects in material and workmanship for a period of two years from the date of shipment thereof. Within the warranty period, manufacturer will repair or replace such products which are returned to it with shipping charges prepaid and which will be disclosed as defective upon examination by the manufacturer. This warranty will not apply to any product which will have been subject to misuse, negligence, accident, restriction, and use not in accordance with manufacturer's instructions or which will have been altered or repaired by persons other than the authorized agent or employees of the manufacturer.

DISCLAIMER

The provisions of the paragraph "Warranty" are the sole obligations of the manufacturer and exclude all other warranties of merchantability, expressed or implied. Further, there are no warranties which extend beyond the above warranty.

LIMITATION OF LIABILITY

In the event of any claim or breach of any obligations of manufacturer under any order, whether expressed or implied, and particularly in the event of any claim or a breach of the warranty or warranties contained in the paragraph "Warranty" or of any other warranties, expressed or implied which might, despite the paragraph entitled "Disclaimer," be determined to be incorporated in any order, the company shall under no circumstances be liable for any consequential or special damages, either in law or in equity, or for losses or expenses or claims for the same arising from the use of, or inability to use, the products of the manufacturer for any purpose whatsoever.

WARNING: The entire machine safety system must be tested at the start of every shift. Machine testing should include: (1) proper machine operation and stopping capability; and (2) verification of proper installation and settings of all point of operation guards and devices before the operation is released for production.



Sales and Marketing Offices

United States

Pinnacle Systems, Inc.
P.O. Box 100088
Pittsburgh, PA 15233

Toll Free Number: 800-569-7697
Direct Number: 412-262-3950
Fax: 412-262-4055

Canada

Pinnacle Systems, Inc.
8-1734 Orangebrook Court
Pickering, Ontario L1W 3G8

Toll Free Number: 888-285-8885
Direct Number: 905-831-1111
Fax: 905-831-40

Customer Service: (630) 443-8542

We have designed our equipment to the very highest performance and safety standards known to the current technological state of the art, as evidenced by our U.S.A. and foreign patents issued and pending. However, the installation, usage, suitability, and fitness of our equipment for any purpose, known or unknown, is interdependent upon the performance of other equipment not manufactured, installed, secured or maintained by Pinnacle Systems, Inc.

We cannot and do not accept responsibility for any overall system performance when factors, such as these, are beyond our control.

www.pinnaclesystems.com

sales@pinnaclesystems.com
service@pinnaclesystems.com