

# Model CA

Cascading Safety Light Curtain

# Installation Manual

**PINNACLE**  
S Y S T E M S , I N C.

[www.pinnaclesystems.com](http://www.pinnaclesystems.com)

Manual Revision History				
Revision Number	Revision Date	Authorized Name	Description	Filename
1.0	12/3/2009	DK	Creation of Manual	Model CA _28-156.pdf
1.1	4/20/2010	DK	Page A-3: addition of Figure 2c and corresponding chart Page A-17: Revision of Figure 12a and 12b Page D-2: Revision of Table 7a and 7b Page D-3: Revision of Table 8a and 8b Page F-1: Revision/addition of part numbers	Model CA _28-156R1.1.pdf
1.2	5/25/2010	DK	Page A-10: Table 2a, Terminal #4 Revision	Model CA _28-156R1.2.pdf
1.3	8/19/2010	DK	Page A-5: Shock/Vibration Paragraph Addition	Model CA _28-156R1.3.pdf
1.4	8/27/2010	DK	Page A-2: Paragraph addition to Manual Latching Reset Appendix A: Message additions to Tables 7a, 8a and 8b.	Model CA _28-156R1.4.pdf
1.5	6/7/2011	DK	Page A-4: Additional Remote Status Display information added	Model CA _28-156R1.5.pdf

# **Model CA**

# **Cascading Safety Light Curtain**

## **Installation Manual**

**Pinnacle Systems, Inc.**  
3715 Swenson Avenue  
St. Charles, IL 60174

P/N: 28-156R1.5

## Proper Usage and Limitations

The information disclosed herein includes proprietary rights of the manufacturer. Neither this document nor the information disclosed herein shall be reproduced or transferred to other documents, used or disclosed to others for manufacturing purposes, or for any other purposes, except as specifically authorized in writing by the manufacturer. If this manual is supplied in connection with the sale or delivery of manufacturer's equipment, it is to be used solely for maintenance, repair, or installation of such equipment.

The Model CA was manufactured in the United States. The Installation Manual was printed in the United States.

You must read and fully understand the following information pertaining to the proper use and limitations of your Model CA:

- The Model CA must be installed by qualified personnel only.
- The Model CA must NOT be used on full revolution presses or any machine that cannot be commanded to stop at any time.
- **Model CA OUTPUT CIRCUITS 1 & 2 MUST BE USED WITH EITHER "CONTROL RELIABLE" PLC INPUT CIRCUITS OR A SAFETY RELAY MODULE.**
- The mechanical power press on which the Model CA is installed must meet ANSI B11.1-1988 and OSHA 1910.217 regulations. These include inspection and maintenance procedures that must be followed to comply with the regulations. The manufacturer will NOT take responsibility for improperly maintained machinery.
- Point of operation safeguarding is defined in ANSI B11.19-2003. This regulation is used to determine a safe distance to place your Model CA. The manufacturer takes no responsibility for injury as a result of improper safeguarding or improper safe distances.
- The Model CA may not be able to safely stop a press which has a faulty stopping mechanism. The manufacturer cannot be held responsible for an improperly maintained or faulty stopping mechanism.
- The Model CA must be checked before put into operation. Follow instructions provided in this manual for procedures on how to do this.
- The Model CA should never be modified or repaired except by qualified personnel and upon authorization of the manufacturer. Never operate machinery that is not in full working order.

- Make sure that all maintenance people, machine operators, die-setters, foreman, and supervisors have read and understood this manual and all procedures have been and will be followed.
- All procedures in this manual must be followed. The manufacturer cannot take responsibility for operation if all procedures and warnings in this manual are not followed.

## Warranty

Manufacturer warrants that this product will be free from defects in material and workmanship for a period of one year from the date of shipment thereof. Within the warranty period, the manufacturer will repair or replace (at our discretion) any product that is disclosed as defective upon examination by the manufacturer and is returned with shipping charges prepaid. This warranty will not apply to any product that has been subjected to misuse, negligence, accident, restriction, and use not in accordance with manufacturer's instructions or which will have been altered or repaired by persons other than the authorized agent or employees of the manufacturer.

## Disclaimer

The provisions of the warranty are the sole obligations of the manufacturer and exclude all other warranties of merchantability, expressed or implied. Further, there are no warranties that extend beyond the above warranty.

## Limitation of Liability

In the event of any claim for breach of any obligations of the manufacturer under any order, whether expressed or implied, and particularly in the event of any claim of a breach of the warranty or warranties contained in the paragraph "Warranty" or of any other warranties, expressed or implied which might despite the paragraph entitled "Disclaimer," be determined to be incorporated in any order, the company shall under no circumstances be liable for any consequential or special damages, either in law or in equity, or for losses or expenses or claims for the same arising from the use of, or inability to use, the products of the manufacturer for any purpose whatsoever.

We have designed our equipment to the very highest performance and safety standards known to the current technological state of the art. However, the installation, usage, suitability, and fitness of our equipment for any purpose, known or unknown, is interdependent upon the performance of other equipment not manufactured, installed, or secured or maintained by the manufacturer. We cannot and do not accept responsibility for any overall system performance when factors, such as these, are beyond our control.

We will not supply individual component parts of any circuit board but will supply the individual circuit board complete. Individual detectors or emitters are available as a complete tested unit.

**WARNING:** The entire machine safety system must be tested at the start of every shift. Machine testing should include: (1) proper machine operation and stopping capability; and (2) verification of proper installation and settings of all point of operation guards and devices before the operation is released for production.

**FILL THIS INFORMATION OUT IMMEDIATELY**

Purchase Date: \_\_\_\_\_

Model No.: \_\_\_\_\_

Options: \_\_\_\_\_

Purchased From: \_\_\_\_\_

Serial No.: \_\_\_\_\_

Microprocessor Revision No.: \_\_\_\_\_

**This information will be needed in the event you need assistance.**

# Table of Contents

## Introduction

Theory of Operation .....	iii
The System.....	iii
System Safety .....	iii
Safety Features.....	iii

Specifications .....	A-1
----------------------	-----

## Standard Features

Solid State Outputs (OSSD) .....	A-2
Digital CAN data Network .....	A-2
External Device Monitor (EDM) .....	A-2
Manual Latching Reset (MLR) .....	A-2

## Optional Features

Remote Status Display (RSD) .....	A-3
Auto Blank.....	A-5
Floating Blank .....	A-5
Safety Relay Module.....	A-5

## Installation Procedures

System Check.....	A-6
Aligning Pylons .....	A-7
Aligning Mirrors .....	A-7
Operations .....	A-8
ANSI Standard B11.19.2003.....	A-9
Safeguarding with Mechanical Guards .....	A-10
Light Curtain Test Procedure.....	A-10
Wiring.....	A-11

## Safety Relay Module

Solid State Safety Relay Interface .....	B-1
Description and Function .....	B-1
Operating Modes/System Functions.....	B-1
Proper Use.....	B-2
Installation.....	B-3
Specifications.....	B-4

## Accessories

Cornering Mirrors.....	C-1
Pedestal Mounting .....	C-2
Swing-Arm Mounting Bracket .....	C-2

## Appendix A: Diagnostics & Troubleshooting

Emitter Pylon - Master .....	D-2
Emitter Pylon - Slave .....	D-2
Receiver Pylon - Master.....	D-3
Receiver Pylon - Slave.....	D-3

## Appendix B: Regulations and Guidelines

OSHA Regulations .....	E-1
Machine Control Reliability Requirements .....	E-1
Safety Guidelines and Management	
Operational Safety .....	E-2
Power Press Guarding .....	E-2
Power Press Care through Inspection and Maintenance .....	E-3
Safety Enforcement .....	E-3
Supervisor Training .....	E-3
Operator Training .....	E-3

## Appendix C: Replacement Parts

Pylons .....	F-1
--------------	-----

## Figures

Figure 1: Standard RSD .....	A-3
Figure 2a: Floating Blank .....	A-3
Figure 2b: Auto Blank .....	A-3
Figure 2c: 52-260 RSD and corresponding chart .....	A-3
Figure 3: Mirror Alignment .....	A-7
Figure 4: Minimum Object Sensitivity and D(pf) .....	A-9
Figure 5: Wiring Diagram with EDM .....	A-12
Figure 6: Wiring Diagram .....	A-13
Figure 8: Swivel Bracket Dimensions .....	A-14
Figure 9: Swivel Bracket Dimensions, pylon dimensions (by model), and additional cable information .....	A-15
Figure 10: Swivel Bracket Dimensions CE, pylon dimensions (by model), and additional cable information .....	A-16
Figure 11: Fixed Bracket Dimensions, pylon dimensions (by model), and additional cable information .....	A-17
Figure 12a: RSD Plate with Floating or Auto Blank Dimensions .....	A-18
Figure 12b: RSD Plate - No Blanking .....	A-18
Figure 13: Installation Pressure Electrical .....	B-3
Figure 14: Installation Pressure Electrical .....	B-3
Figure 15: Solid State Safety Relay Installation .....	B-5
Figure 16: Cornering Mirror Dimensions .....	C-1
Figure 17: Pedestal Dimensions .....	C-2
Figure 18: Swing-Arm Mounting Bracket .....	C-2

## Tables

Table 1: Mechanical Guards .....	A-10
Table 2a: Emitter Pylon Wiring .....	A-11
Table 2b: Receiver Wire Colors .....	A-11
Table 2c: Optional RSD .....	A-11
Table 3: Function Diagram .....	B-2
Table 4: Safety Relay Wiring Table .....	B-3
Table 5: Specifications .....	B-4
Table 6: Cornering Mirror Dimensions .....	C-1
Table 7a: Emitter Pylon Master .....	D-2
Table 7b: Emitter Pylon Slave .....	D-2
Table 8a: Receiver Pylon Master .....	D-3
Table 8b: Receiver Pylon Slave .....	D-3

# Introduction

## Model CA Product Overview

Cascading safety light curtains provide the user the ability to connect additional sets of light curtains by daisy chaining multiple emitters and receivers together. The interconnecting cables are factory supplied and the user defines length. The cascading of safety light curtains provides multiple areas of guarding in any plane (X, Y, Z), while utilizing the control reliable dual safety outputs from the Category 4 safety device for the safety outputs to the machine control. The ability to guard multiple areas on irregular shaped machines by cascading safety light curtains reduces wiring and provides a lower cost yet effective machine guarding solution.

The Model CA Cascading Safety Light Curtain is an infrared safety light curtain that is designed to the IEC 61496 standard. When properly installed, it protects the machine operator by passing an invisible infrared light beam across an area to be guarded and examining whether or not the light beam(s) are blocked. If the light beam(s) are blocked, monitored solid state outputs will open, issuing a "STOP" command to the machines normally closed (N.C.) "STOP" circuit. The Model CA System is composed of transmitting units (EMITTERS), and receiving unit (RECEIVERS). The entire system is control reliable Category 4 (per IEC 61496). A single fault anywhere within the Model CA will not prevent at least one of the solid state outputs from opening up, (allowing a "STOP" command) when either a beam is broken or an internal fault occurs.

### **Theory of operation.**

The Model CA Cascading Safety Light Curtain protects an area by projecting a curtain of infrared light. The infrared emitters and receivers face each other across the field to be protected. Each LED pair is spaced along the length of the pylons at regular intervals from .5" (12mm), up to 8" (203mm) depending on the application. The smaller spacing are for finger guarding, the larger spacing are for body protection. The emitter/receiver pairs are scanned sequentially (one at a time) by a very short pulse of infrared light starting from bottom (cable end), and working up to the end, until every beam pair has been scanned. Two 16 bit computers in the first emitter pylon and two 16 bit computers in the first receiver pylon control the operation, as well as cross check each pylon.

### **The System.**

The Model CA Cascading Safety Light Curtain employs infrared technology in a small sealed NEMA 4 (IP 67) aluminum housing with an infrared passing (daylight filtering) acrylic lens. This system provides harmless invisible protection and an unobstructed view of the guarded area. There are two parts to the Model CA: An Emitter pylon and a Receiver pylon. The Emitter pylon has no outputs. The Receiver pylon contains two monitored solid state 24vdc outputs. Both pylon sets are synchronized to each other electronically as they are connected together with the interconnect cables to the top and bottom of the next set of pylons.

### **System Safety.**

The Model CA Cascading Safety Light Curtain incorporates redundant, and diverse technology that provides a backup for every system that could cause an unsafe condition.

### **External Device Monitoring (EDM).**

A method in which the Model CA Category 4 cascading safety light curtain logic monitors the state of various external control devices. The control devices are external and not part of the Model CA light curtain pylons. A lockout or stop signal will result if an unsafe state is detected in an external device. The External Device Monitoring (EDM) is an optional function of the Model CA safety light curtain for monitoring the status of external devices such as gate and door switches, safety switches or the main control element of the drive (MPCE). Solid state outputs are turned on separately to be checked and to assure neither output has been shorted, before fully turning on.

### **Design Criteria.**

Designed to meet IEC 61496-1 & 2, UL 1998, UL subject 491, OSHA, ANSI, CSA, ANSI-RIA R15.06-1999

Microprocessor redundancy for both Emitter and Receiver pylons

Redundant, monitored, 24vdc solid state outputs (PNP)

Watchdogs on CPU's and outputs prevent unintentional output during lockups.



# Specifications

## Model CA Cascading Safety Light Curtain

### **Input Power**

*Emitter pylon:* 24vdc @ .125A

*Receiver pylon:* 24vdc @ .125A (solid state outputs are PNP which may draw up to .25A additional)

### **Internal fuses**

*Emitter Pylon:* F1 @ 1A

*Receiver Pylon:* F1 @ 1A, F2 @ 1/2A, F3 @ 1/2A

### **Outputs (OSSD)**

*Receiver pylon:* monitored, 2 outputs, solid state PNP (24vdc when GREEN, float when RED/off). Max .25A draw each.

### **Indicators**

*Emitter pylon:* Yellow, Red, Green.

*Receiver pylon:* Yellow, Red, Green.

### **Construction**

Painted aluminum extrusion with Acrylic IR lens and Viton Seals providing NEMA 12,13 protection.

Optional Polycarbonate tubes (sleeves) over the pylons provides NEMA 4 protection.

Cables are both 21' (6400mm) long with an in-line connector 1' (305mm) from the base of each pylon.

*Emitter pylon:* Four conductor 24AWG

*Receiver pylon:* Six conductor 24AWG

Pylons: Yellow

Cables: Black

### **Temperature**

0 to 50c (up to 95% humidity, non-condensing)

### **Dimensions**

1.45" (36.8mm) square X selected length (see tables for lengths)

### **Beam Spacing & Minimum Object Sensitivity (MOS)**

.5" (12.7mm) .55" (14mm) MOS

1" (25.4mm) 1.18" (30mm) MOS

4" (101.6mm) 5"

(special order, 4" (101.6mm) active area followed by a 4" gap) 8" (203.2mm)

(special order, 4" (101.6mm) active area followed by a 8" (203.2mm) gap)

### **Response Time and Scanning Frequency**

< 30 mSec total, 10 khz

### **Shock**

Tested to withstand high vibration (using shock mounts)

### **Self-Checking**

Every 15mSec

### **Scanning Distance**

From 1' to 20' (305mm-6,096mm) standard (depending on model ordered)

From 21' to 50' (6400mm-15,240mm) extended range (optional)

The range is stated as a two digit number within the Model #

# Standard Features

## Model CA Cascading Safety Light Curtain

### Solid State Outputs (OSSD)

**Description:**

Two optically isolated solid state PNP outputs (.25A output max each). Each output is monitored to assure that 24vdc is not present when the output is turned OFF, and is present when turned ON.

**Output Configuration:**

Same States: Output1 (blue wire) & Output2 (brown wire) are both 24vdc PNP N.O. "held closed" (24vdc when Green).

**Operation:**

Same States: When the guard is GREEN, both Outputs are ON (24vdc out). When the guard is RED, Faulted, or not powered, both Outputs are OFF.

**Output Testing:**

Same States: Before the guard goes GREEN, Output1 is turned ON first and Output2 (which is still OFF) is monitored for voltage on its output. If Output2 is found OFF, then Output2 is turned ON. This takes ~20mSec between Output1 and 2 turning back ON.

**IMPORTANT: OUTPUTS 1 & 2 MUST BE USED WITH EITHER "CONTROL RELIABLE" PLC INPUT CIRCUITS OR A SAFETY RELAY MODULE.**

**WARNING: NEVER USE OUTPUTS 1 & 2 TO CONTROL RELAY(S) OR VALVE(S).**

### Digital CAN data network

**Description:** Twisted pair data network designed for high electrical noise environments. Allows the Receiver pylon to talk to a remote operating device as well as the Emitter pylon. You should link the Emitter and Receiver pylon via CAN if you are powering up both pylons from the same supply. This eliminates the need for a sync channel (the bottom beam used to synchronize the pylons).

**Operation:** When the Emitter and Receiver pylons are connected together via this network, the Emitter pylon becomes digitally linked to the Receiver pylon. The Emitter pylon synchronizes via the CAN data network to the Receiver pylon instead of using the bottom beam (beam closest the cable). Pylon status is displayed on both pylons.

### External Device Monitor (EDM)

**Description:**

Allows the CA to monitor a pair of low cost external Safety Relays as opposed to the more expensive Safety Relay Module (SSSR).

**Wiring:**

Wire the N.C. force-guided contact of each of the pair of Safety Relays in series. Wire Ground to one side and the other to the CA EDM input wire (ORANGE). (See 28-141 Drawing for details).

**Operation:**

The CA EDM input must be at GROUND when the curtain is RED (blocked or faulted), and OPEN when the curtain is GREEN (clear). If either external Safety Relay output contact remains closed, the CA EDM input will remain Open and a fault will occur when the curtain is RED. This fault will open up the remaining Safety Relay contact and lockout.

### Manual Latching Reset (MLR)

**Description:**

When this feature is activated, the guard will stay in a RED condition when blocked, even when the blockage is removed.

**Wiring:**

Wire a N.O. push button between GROUND and the CA MLR input wire (PINK) (see 38-040 Drawing)

**Operation:**

Clear the guard of blockage and push/release the MLR button. This will reset the guard as long as the curtain is properly aligned (no blockage) and no faults.

To temporarily disable the built-in latching option (for alignment purposes) you need to plug in the optional Remote Status Display (RSD) with AutoBlank device. Cycling the AutoBlack key from OFF to Mode 3 and back to OFF will disable Latching. Unplugging the RSD will restore Latching.

### Remote Status Display (RSD)

**Description:** Allows AutoBlank and/or FloatingBlank optional features to be added to the Model SS. Includes a four character diagnostics / status display.

**Operation:**

Allows you to view current feature modes and status as well as fault conditions.

The Yellow status light indicates when you are in any blanking mode.

**Manual Latching Reset:**

Install jumper on the left 2 vertical pins of J2, to enable Manual latching reset feature.

Install a N.O. push button between J4 (right terminal) and +24vdc.

To reset after blocking the guard, you must clear the guard then push the N.O. button.

**Cincinnati Interface (manual output Test):**

If you apply +24vdc to Pin 1 of J4 (left terminal), the display will show a "CINN" and force the "RED" shutting down both outputs 1 & 2.

This allows a remote device to manually check that both outputs can and will shut OFF.

Figure 1: Standard RSD

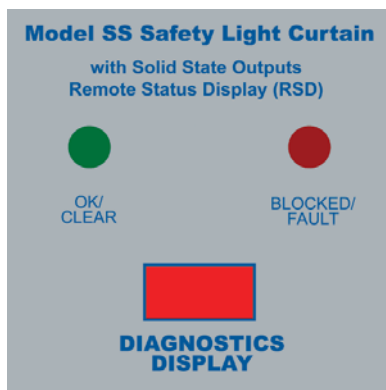

Figure 2a: Floating Blank

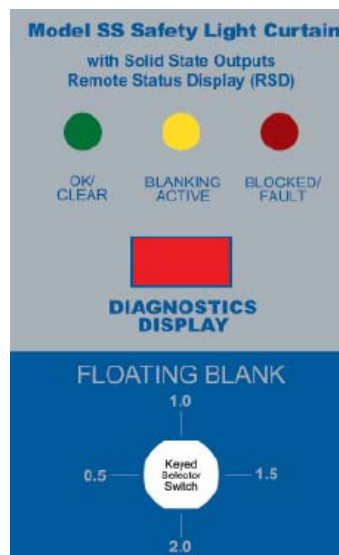

Figure 2b: Auto Blank

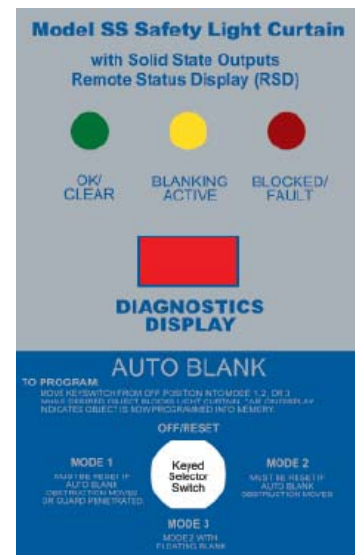
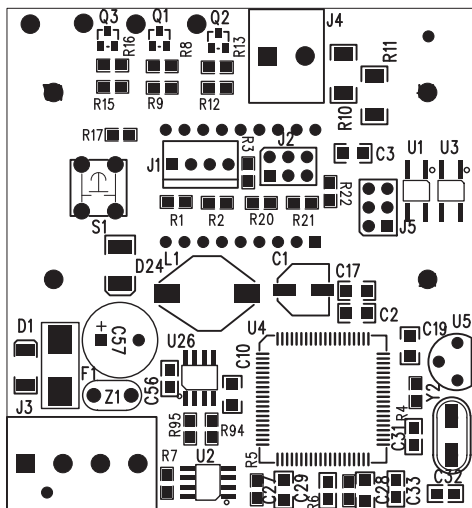

Figure 2c: 52-260 RSD and corresponding chart



J1	For AB/FB keyswitch	
J2	Left set of pins	Activates Latching Outputs when jumpered
J2	Center set of Pins	Factory Use only
J2	Right set of pins	Activates Cincinnati Interface when jumpered
J3	1	+24vdc power input (0.1A)
J3	2	Ground
J3	3	CAN_H (Green wire)
J3	4	CAN_L (White wire)
J4	1	Input from Cincinnati Interface Press
J4	2	Input from Latching Output Reset button
J5	Factory Use only	

= Terminal #1

J Designators = Connectors

F Designators = Fuses

F1 = 1A slo-blo fuse

# Optional Features

## Model CA Cascading Safety Light Curtain

### Remote Status Display (RSD) Continued

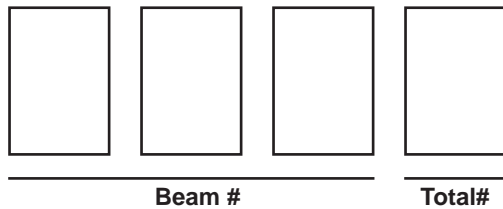

The first three numbers displayed represent the first problem beam on the guard starting from the cable end of the pylon. The fourth number represents the total number of beams blocked on the guard. Depending if your beam spacing is 0.5" or 1.0" you can determine which board in the pylon is bad.

#### Definitions

- BEAM #:** Indicates first blocked beam (from cable end). (i.e. 64 = 64" up with 1.0" beam spacing, or 32" up with 0.5" spacing)
- TOTAL #:** Indicates total number of blocked beams on the curtain. (i.e., 1 to 9 beams then A to F = 10 to 15 beams)

The Diagnostics Display has two modes of operation: Status and Fault. If a fault occurs, the display will scroll the fault message until the power is removed.

#### Status Display Messages

##### Normal Operation

- TEST** Testing internal systems
- RST** Unit waiting for Push of FN1 (located on control module power supply board middle left hand side)
- RDY** Normal operation

##### Obstruction

- 03 >** 15 or more beams blocked starting 3 beams up from cable end
- 153** 3 beams out starting 15 beams up from cable end

#### Floating Blank

- FB1** 1 beam float maximum
- FB2** 2 beams float maximum
- FB21** 2 beams float maximum, 1 beam is blocked
- OBST** More than 2 separate objects detected in curtain

#### Auto Blank

- AB3** 3 beams programmed in as an Auto Blank object
- PENT** Mode 1 penetration into guard
- SIZE** Total number of allowable blanked beams exceeded during programming
- MOVE** Auto Blank object(s) moved, uncovering beam(s)

#### Cincinnati Interface

- CINN** Guard has de-energized safety relays, forcing a false blockage mode

#### MULTI-PYLON (MP)

##### Description:

Multiple sets of light curtains operating independently can be modified to operate together to prevent infrared interference between each other, and optionally to provide a single Dual Safety Output.

##### Wiring:

The Pink wire of each Receiver pylon must be connected together as well as the White wires connected together.

##### Operation:

Standard= Each curtain uses its own Safety Outputs, but do not interfere with each other.

Single Output: Blocking 1 curtain will shut down the Safety Outputs of all connected light curtains.

## AutoBlank

**Description:** Allows a permanent obstruction (i.e. conveyer) to be programmed into the light curtains field of view.

If the obstruction moves, the outputs will turn off.

**WARNING:** Do not program in obstructions that allow the operator to reach around (i.e. obstructions that do not span from Emitter pylon to Receiver pylon).

**NOTE:** When the AB KEY is moved into a MODE, a new learned AB pattern is stored in non-volatile memory inside the Model CA Receiver (RX) pylon. If the KEY remains in the same MODE during future power-ups, the previous learned AB pattern is loaded in automatically. Once the AB KEY is moved back to OFF, the previous AB pattern is lost.

**Application:** To program out a conveyer that maybe within the field of view of the curtain.

**Operation:** With an obstruction in place, turn the key-switch from "OFF" to any mode of operation.

The computers in the Receiver pylon will learn the obstruction pattern and store it (while the power remains on). If the obstruction moves, the outputs will turn off and remain off until the obstruction is replaced in the exact location, or the AB is turned back to "OFF"

### Mode Description:

- |                  |                                                                                                                                                                                                                                                        |
|------------------|--------------------------------------------------------------------------------------------------------------------------------------------------------------------------------------------------------------------------------------------------------|
| <b>OFF/RESET</b> | AB turn off (resets obstruction pattern back to CLEAR)                                                                                                                                                                                                 |
| <b>Mode #1</b>   | Mode #2 with output Latching. Acts like Mode #2 and in addition when the curtain is blocked, the outputs will remain OFF (even if you are no longer blocking the curtain) until the key switch is first moved to "OFF" then back to Mode #1.           |
| <b>Mode #2</b>   | The obstruction in the curtain at the time the keyswitch is moved into this position is programmed into memory. The curtain will turn GREEN (outputs turn ON) as long as the permanent obstruction is not moved and no additional obstructions appear. |
| <b>Mode #3</b>   | Mode #2 with one beam Float. Acts like Mode#2 but allows one additional beam to be blocked while remaining GREEN.                                                                                                                                      |

## FloatingBlank

**Description:** Allows a particular number of beams to be blocked while allowing the outputs to remain ON (GREEN)

**Application:** When the part being manufactured must protrude into the curtains field of view.

**Operation:** Set the keyswitch to the lowest number of FB beams needed to do the job.

**WARNING:** The Penetration Depth Factor D(pf) must be determined to account for any FloatingBlank beams

### Floating Blank - (8K) Option

The "Floating Blank" option provides the flexibility necessary to effectively guard all types of equipment that require multiple floating beams. This is quite common in the fabricating industry where the work piece moves.

The "Floating Blank" permits work pieces to be formed vertically or horizontally through the guarded area without shutting down the machine. Entry into the protected area by the operator or passerby will prevent the start or, if the machine is in motion, will provide a signal to stop the machine.

The "Floating Blank" is controlled by a keyed selector switch that will allow a work opening of 2" (51mm) based on 1/2" (13mm) increments (shown left). This information is displayed on the message display of the controller. Blanking adjustments required when die heights change are not necessary. The "Floating Blank" light curtain automatically adjusts to the various feed positions providing **production with protection**.

#### The "Floating Blank" (8K) Option includes:

- |                      |                               |
|----------------------|-------------------------------|
| <b>1/2" (13mm)</b>   | - Constant scan light curtain |
| <b>1" (25mm)</b>     | - One floating beam           |
| <b>1-1/2" (38mm)</b> | - Two floating beams          |
| <b>2" (51mm)</b>     | - Three floating beams        |

## Safety Relay Module

**Description:** Connects the two PNP solid state outputs from the Model CA to two safety force guided relays. The Safety Relay must allow 2 inputs from an OSSD device.

**Application:** Provides the Model CA with dry relay contacts that are monitored for correction position.

**Operation:** Consult the operations manual for the particular Safety Relay device.



# Installation Procedures

## Model CA Cascading Safety Light Curtain

**WARNING:** The entire machine safety system must be tested at the start of every shift. Machine testing should include: 1) Proper machine verification of proper installation and settings of all point of operation guards and devices before operation is released for production.

**WARNING:** The Model CA should be mounted in a manner so that only authorized personnel can change the mounting or location, and that the safety distance is recalculated each time its position is changed.

**WARNING:** Additional mechanical guards may be required to prevent the operator from standing between, reaching over, under, or around the light curtain to the hazardous point of operation.

**NOTE:** Other infrared sources (i.e. other light curtains, etc) can interfere with operation and prevent the light curtain from properly aligning and giving a GREEN indication. Make sure that the RECEIVER pylon cannot view other infrared Emitters (except its own EMITTER pylon).

**NOTE:** Shock Mount the pylons if they are to be directly mounted onto a high vibration machine.

**NOTE:** The Model CA is a low voltage (24vdc) low current device. Make sure to keep Model CA wiring away from high voltage / high current components and/or wiring.

1) **TEST:** Before installation, test curtain by connecting the EMITTER & RECEIVER power together to a 24vdc supply. Point the pylons toward each other and verify a GREEN indicator light when clear and a RED when blocked. (see Appendix A for Diagnostics & Troubleshooting)

2) **SAFETY DISTANCE:** Determine the Safety Distance for the light curtain (distance from the nearest hazardous point to the curtain field) based on light curtain and machine response times (see ANSI Standard B11.19 2003 section)

3) **SHOCK/VIBRATION:** Determine if any part of the Microguard is to be directly subjected to either excessive shock and/or vibration. If so, mount the subjected parts to your equipment using shock-mount devices (such as Part# 21-019). Shock and/or Vibration damage is not covered under warranty.

4) **MOUNT:** Mount both pylons with the connector end in the same direction (either up or down) across the

hazardous area at a distance from the hazardous point of operation, equal to or greater than the calculated safety distance (step 2)

5) **CONTROL PANEL:** Mount 24vdc supply and "Safety Relay Module" inside your control panel. Both EMITTER and RECEIVER pylons require 24vdc power. Only the RECEIVER pylon requires the "Safety Relay Module"

6) **MIRRORS:** Use mirrors to turn a corner 90deg or more, but no less. If you are using pedestals, do not permanently mount them until you have finished the installation procedure. When you have finished aligning the pylons and can achieve a GREEN indicator, bolt the stands to the floor. Make sure the bottom edge of the mirror(s) are below the bottom beam of the curtain and the top edge of the mirror(s) are above the top beam of the curtain.

7) **WIRING:** Connect the EMITTER & RECEIVER pylon ground wires together to the power supply ground (black). Connect the EMITTER & RECEIVER pylon 24vdc wires together to the power supply 24vdc output (red). Connect the EMITTER & RECEIVER pylon CAN wires together and to the Remote Status Display (RSD) if applicable (white to white & green to green). Connect both RECEIVER solid state outputs to the "Safety Relay Module" inputs (as stated by the manufacture of the module. Wire the "Safety Relay Module" safety outputs into your machines "STOP" circuit(s) (Please refer to page A-10 for wiring details).

8) **SYSTEM CHECK:** Check the curtains field of view with a round test piece (dowel rod) that has a diameter equal to the minimum object sensitivity of the curtain (see Specifications section). Move the test piece up and down the curtains field of view to make sure the curtain stays RED the entire time and that you cannot run your machine while the curtain is RED.

**WARNING:** If you get a GREEN indication while the test piece is within the curtains field of view, this may be due to any of the reasons: a) an incorrectly sized test piece. b) The Floating Blank option is enabled. c) There is a reflection from adjacent reflective material. In this case you must relocate the curtain away from this material and check again.

9) **ADDITIONAL GUARDS:** Install additional mechanical guards to prevent anyone from getting to the hazardous point of operation by reaching around, over or under the light curtain. Also, to prevent anyone from getting in between the curtain and the hazardous point of operation, install horizontal light curtains or safety mats.

### Aligning Pylons

Mechanically line up the pylons so they are looking straight at each other. Twist the pylons to find the center of their sweet spot (the point at which you get a solid GREEN indicator). If you are trying to run the pylons close to the maximum operating distance, you may have to tip one end of the Emitter pylons to get a GREEN indication.

### Aligning Mirrors (refer to Figure 3)

Every mirror you add reduces the maximum operating distance by 10%-15% and also increases the difficulty of alignment. Because of the width of the mirrors and the shoulders of the aluminum extrusion that protect the mirror, you cannot turn a corner less than 90°.

The vertical height of the mirror with respect to the vertical height of the pylons should be such that the mirror matches the beam area of the pylons. You should have some mirror showing above the top beam and below the bottom beam.

All mirrors and pylons should be plumb. You should be able to stand in front of one of the pylons, look straight ahead, and see the other pylon through the center(s) of the mirror(s). Depending on what the diagnostics display reads, you may have to tip one end of the mirror to get the remaining blocked beams to come in.

**Figure 3: Mirror Alignment**

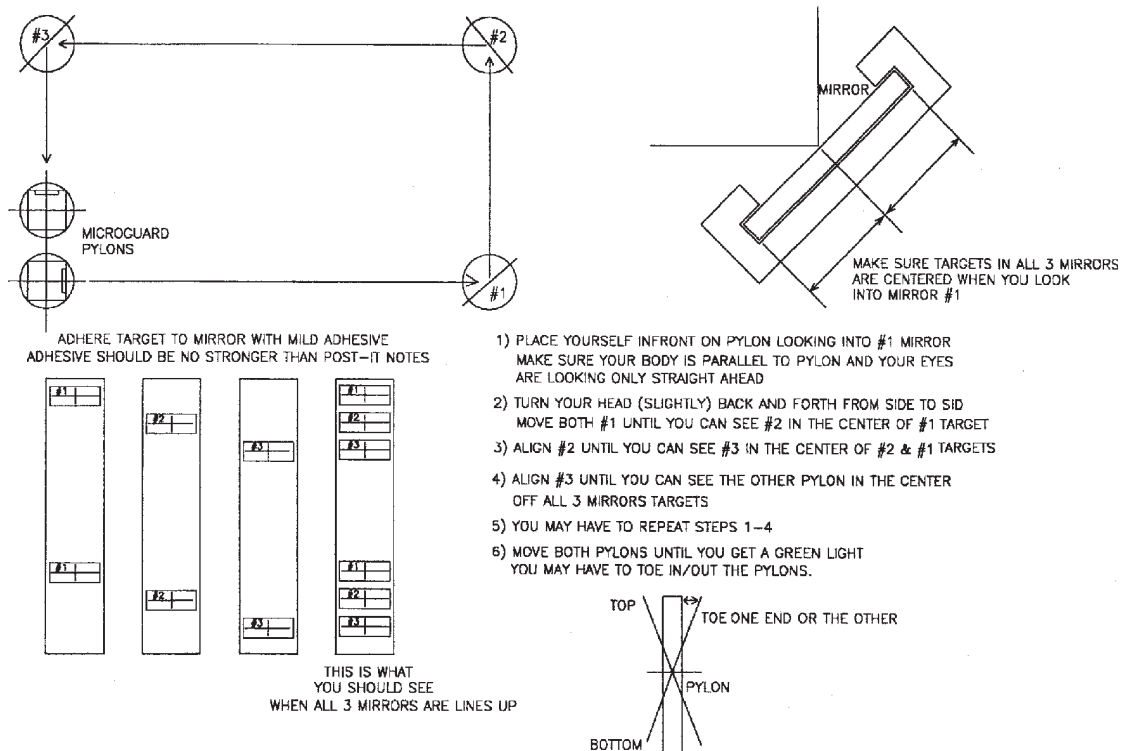

# Installation Procedures

## Model CA Cascading Safety Light Curtain

### Operations

**NOTE:** Examine the Model CA on a daily basis to make sure that the curtain pylons have not been moved and that any mechanical guarding has not been moved or removed.

**WARNING:** If it is possible for someone to go through the light curtain and remain between the curtain and the hazard without blocking the curtain, you must wire your "Safety Relay Module" for manual reset, or install a safety mat or horizontal light curtain to guard this area.

1) **APPLY POWER:** The curtain (both pylons) will go through a power up test. First, both Yellow and Green lights blink 1 time. This indicates the Master and Slave processors are functioning properly. Second, both Yellow and Green lights blink 2 times. This indicates Master and Slave are now in sync with each other.

2) **SYNCHRONIZATION:** The curtain will now determine if the CAN data network is installed. Third, The Green lights will blink: 2 times for infrared synchronization between pylons, 3 times for CAN data network synchronization between pylons. If infrared synchronization is used, the Yellow status light on the Emitter pylon will be on (dim) all the time, with the Red status light blinking periodically, the Receiver pylon will indicate output status. If the CAN data network is used, the Emitter status lights will indicate the current pylon output status (just like the Receiver side).

3) **STATUS INDICATORS:** Solid Green=Curtain clear (no blockage, or faults) and outputs active (+24vdc out). Solid Red=Curtain blocked and outputs off (open). Solid Yellow= Curtain in either AutoBlank or FloatingBlank modes. Blinking lights indicate a fault condition and the outputs will be off (open) (see Fault Codes section)

**IMPORTANT: OUTPUTS 1 & 2 MUST BE USED WITH EITHER "CONTROL RELIABLE" PLC INPUT CIRCUITS OR A SAFETY RELAY MODULE.**

**WARNING: NEVER USE OUTPUTS 1 & 2 TO CONTROL RELAY(S) OR VALVE(S).**



# Installation Procedures

## Model CA Cascading Safety Light Curtain

### ANSI Standard B11.19-2003 Formula for calculating safety distance of light curtains from hazardous point of operation.

The effective sensing field of the device shall be located at a distance from the nearest recognized hazards such that the operator or others cannot reach the hazard with a hand or other body part before cessation of motion during the hazardous portion of the machine cycle.

The point at which a device responds to an intrusion may vary. The devices should be located or adjusted such that the device always responds to the intrusion at or prior to the safety distance. Care should be exercised when installing the device to ensure that it does not detect false signals from other devices in the area.

Usually the electro-optical presence-sensing device is used in a manner that provides a protected zone in front of the primary work area with auxiliary devices or guards used to protect secondary access areas. In some cases, however, mirrors may be used in conjunction with the device to provide 2-, 3-, or 4-sided protection.

The machine stop time should be measured with the machine running at its fastest speed with its heaviest die or tooling and the stop time being measured at the 90° position in the downstroke.

The following formula should be used when calculating the safety distance:

$$D_s = K \times (T_s + T_c + T_r + T_{bm}) + D(pf)$$

- $D_s$  = Minimum safety distance between the device and the nearest point of operation hazard (in inches).
- $K$  = Hand speed constant. This value has been determined by various studies and, although these studies indicate speeds of 63 in/sec to over 100 in/sec, they are not conclusive determinations. The employer should determine this value by considering all factors, including physical ability of the operator.
- $T_s$  = Stop time of the machine tool measured by a stop time measurement device.
- $T_c$  = Response time of the control system (usually is taken care of by the measurement device).
- $T_r$  = Response time of the presence-sending device and it's interface, if any, as stated by the manufacturer or measured by the employer.
- $T_{bm}$  = Additional time allowed for the brake monitor to compensate for variations in normal stopping time.
- $D(pf)$  = Depth Penetration Factor. Added distance as indicated by Figure 2. The minimum object sensitivity is stated by the manufacturer. If a Floating Blank is used, use the Dpf numbers found on Tables 2 and 3.

**Figure 4: Minimum Object Sensitivity and D(pf)**

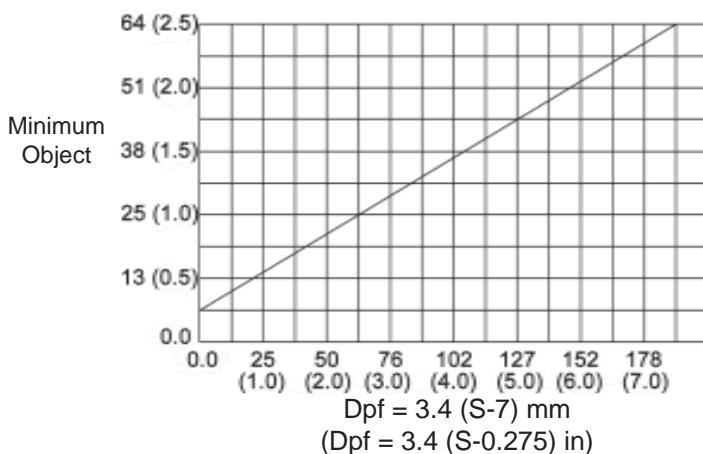

### Penetration factor, Dpf, for presence-sensing devices used in a vertical application with object sensitivity less than 64 mm (2.5 inches)

Dpf, the distance added to the safety distance due to the penetration factor compensates for varying object sensitivities of electro-optical presence-sensing devices.

When blanking features are used and when the blanked area is not completely filled by the workpiece or part, or by mechanical guarding, the minimum object sensitivity can be calculated as:

$$\text{Object sensitivity} = \text{size of the blanked area} + \text{minimum object sensitivity without blanking.}$$

Once this value is found, then determine Dpf.

If the entire blanked area is filled with mechanical guarding or other fixed material or guards, use the device's object sensitivity to determine Dpf.

# Installation Procedures

## Model CA Cascading Safety Light Curtain

### Safeguarding with Mechanical Guards

When a light system is used to protect the operator or passerby from penetration, it must be mounted and properly sized (grid length) so it is impossible to reach under, around, or over into the hazardous point of operation zone. Infrared light systems normally guard the front or feed area of a machine. The sides or the areas where the light screen does not guard must be guarded by some other means.

If the position of the safety light curtain will allow the operator or others to place themselves between the sensing field and the hazardous area, auxiliary guards or devices such as safety mats, barrier guards, or devices should be used in conjunction with the safety light curtain to prevent the operator or others from exposure to the hazardous area. If mechanical guards such as polyurethane, expanded or perforated metal, hairpins, etc. are used to guard these areas, the opening must comply with the OSHA safety distance in relationship to the openings.

After installation of point of operation guards and before a job is released for operation, a check should be made to verify that the guard will prevent the operators hands from reaching into the point of operation or any hazard zone.

Table 4 outlines the distances that guards should be positioned from the nearest point-of-operation hazards.

The various openings are such that for average-sized hands, an operator's fingers will not reach the point of operation.

After installation of point-of-operation guards and before a job is released for operation, a check should be made to verify that the guard will prevent the operator's hands or other body parts from reaching the point of operation.

**Table 1: Mechanical Guards**

Distance of opening from point of operation hazard (inches)			Maximum width of opening (inches)
1/2	to	1-1/2	1/4
1-1/2	to	2-1/2	3/8
2-1/2	to	3-1/2	1/2
3-1/2	to	5-1/2	5/8
5-1/2	to	6-1/2	3/4
6-1/2	to	7-1/2	7/8
7-1/2	to	12-1/2	1-1/4
12-1/2	to	15-1/2	1-1/2
15-1/2	to	17-1/2	1-7/8
17-1/2	to	31-1/2	2-1/8

### Light Curtain Test Procedure

Use a dowel rod (or similar object) with a diameter equal to the M.O.S. (Minimum Object Sensitivity) of the guard you are testing. Move the rod through the field of the curtain (i.e. top to bottom for vertically mounted curtains). Repeat this test close to the Emitter pylon, close to the Receiver pylon, in the middle between the pylons, and most importantly in front of the operator position.

Make sure the curtain indicates a "Blocked" condition (RED light) when the rod is in the field of the curtain.

Check and make sure the machine cannot move when the curtain shows "Blocked". If the machine can operate while the curtain shows a "Blocked" condition, then re-examine your wiring.

NOTE: Always use both safety relays in your STOP circuit(s).

If the curtain does not show "Blocked" when the rod is in the field: Check to make sure the rod is truly in the curtain's field, and re-check the curtain's Minimum Object Sensitivity (including AutoBlank and Floating blank options that change the M.O.S.).

Infrared light from the curtain may be reflecting around the rod due to reflective material too close to the curtain's field. In this case, you will have to move the curtain pylons back away from the reflective material and repeat the test over again. The curtain's power level can also be reduced by the factory.

# Installation Procedures

## Model CA Cascading Safety Light Curtain

### Wiring

Each pylon comes standard with 21' (6400mm) of cable with a quick disconnect in-line connector

Optional longer cables can be purchased (to replace the 20' (6096mm) section). Voltages applied are to never exceed 24vdc.

**Table 2a: Emitter Pylon Wiring**

<b>Emitter Pylon</b>		
<b>Terminal#</b>	<b>Connector</b>	<b>Definition</b>
1	Black	Ground
2	Red	+24vdc regulated input
3	White	CAN_L data network
4	Green	CAN_H data network

**Table 2b: Receiver Wire Colors**

<b>Receiver Wire Colors</b>		
<b>Terminal#</b>	<b>Connector</b>	<b>Definition</b>
1	Red	+24vdc regulated input
2	Black	Ground
3	White	CAN_L data network
4	Green	CAN_H data network
5	Blue	Output 1 (24 vdc when Green) (open when red) (.25A max)
6	Brown	Output 2 (24vdc when Green) (open when Red) (.24A max)
7	Orange	EDM (GND when RED, OPEN when GREEN)
8	Pink	Latching Relay Reset (GND, then OPEN to reset Outputs)

**Table 2c: Optional RSD**

<b>Optional RSD</b>	
<b>Terminal#</b>	<b>Definition</b>
1	+24vdc regulated input
2	Ground
3	CAN_H data network
4	CAN_L data network

**WARNING:** You must wire both Outputs 1 & 2 to a "Safety Relay Module Control Reliable" Safety PLC, when this product is used for safety guarding.

Wire all the Grounds together to the power supply.

Wire all the 24vdc together to the power supply.

Wire all the CAN\_H together

Wire all the CAN\_L together

Wire Output 1 and Output 2 to the "Safety Relay Module" (see manufactures installed instructions)

**IMPORTANT: OUTPUTS 1 & 2 MUST BE USED WITH EITHER "CONTROL RELIABLE" PLC INPUT CIRCUITS OR A SAFETY RELAY MODULE.**



Figure 6: Wiring Diagram

Model CA 28-142 Wiring Diagram (with EDM)

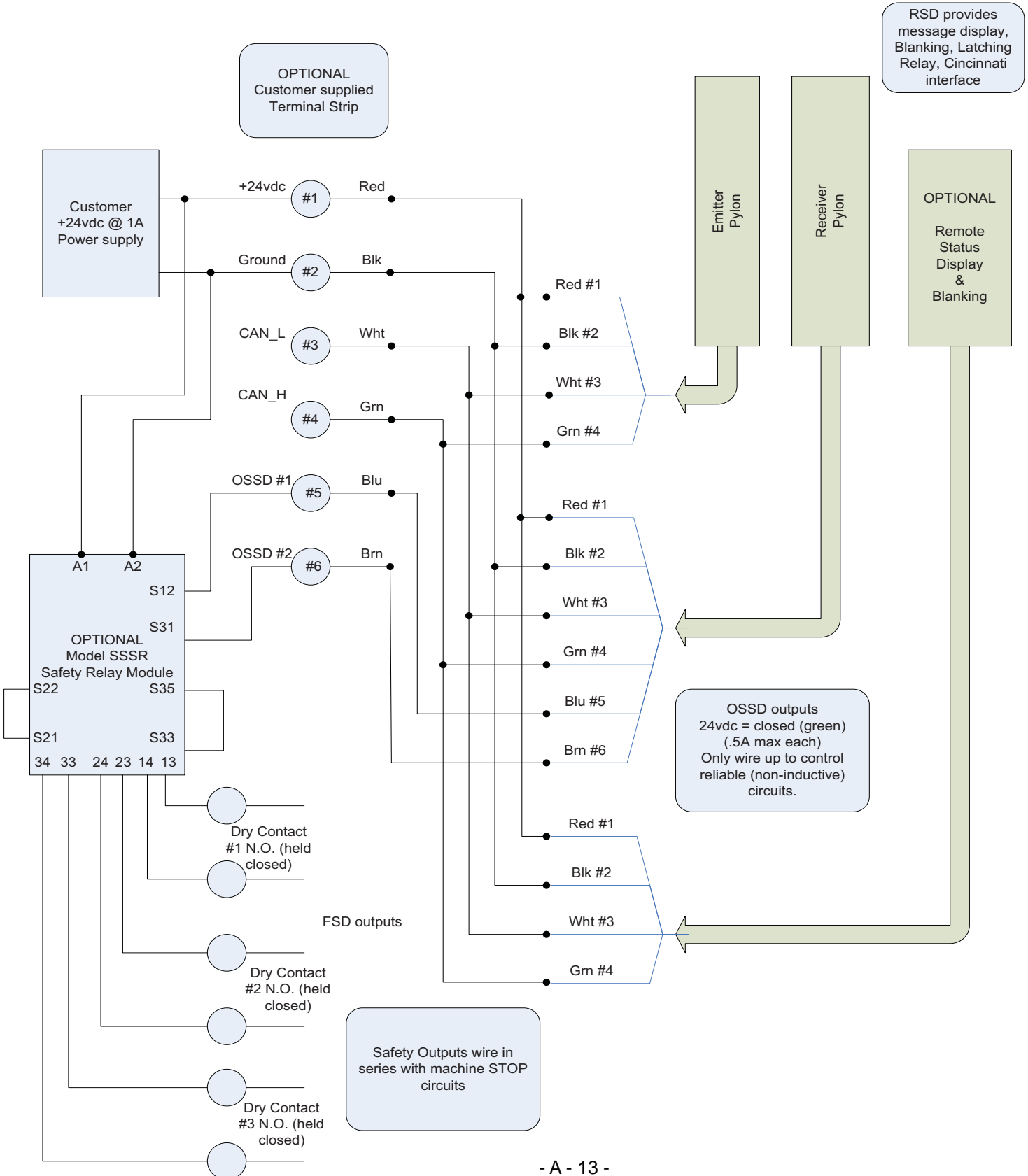

# Dimensions

## Model CA Cascading Safety Light Curtain

Figure 8:

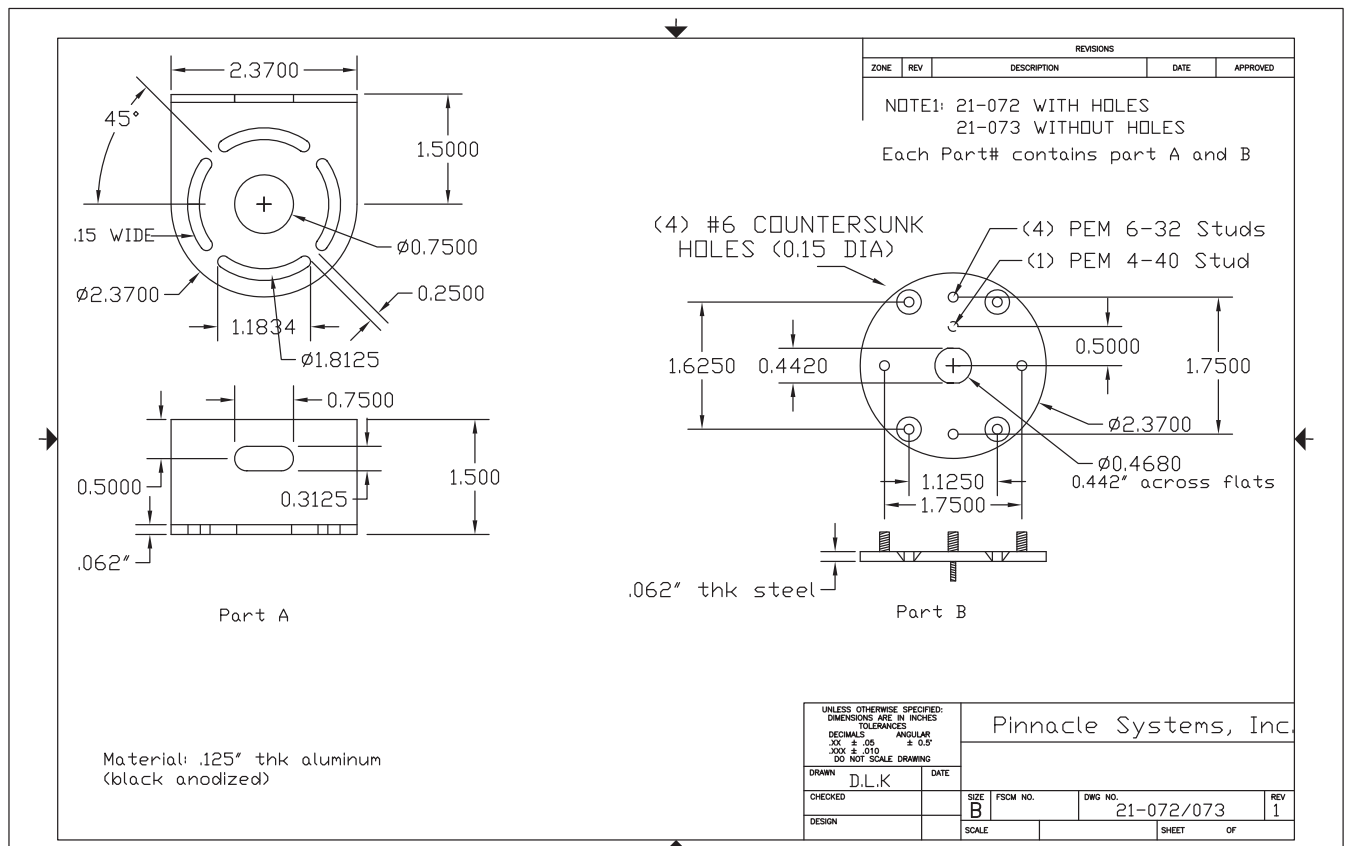
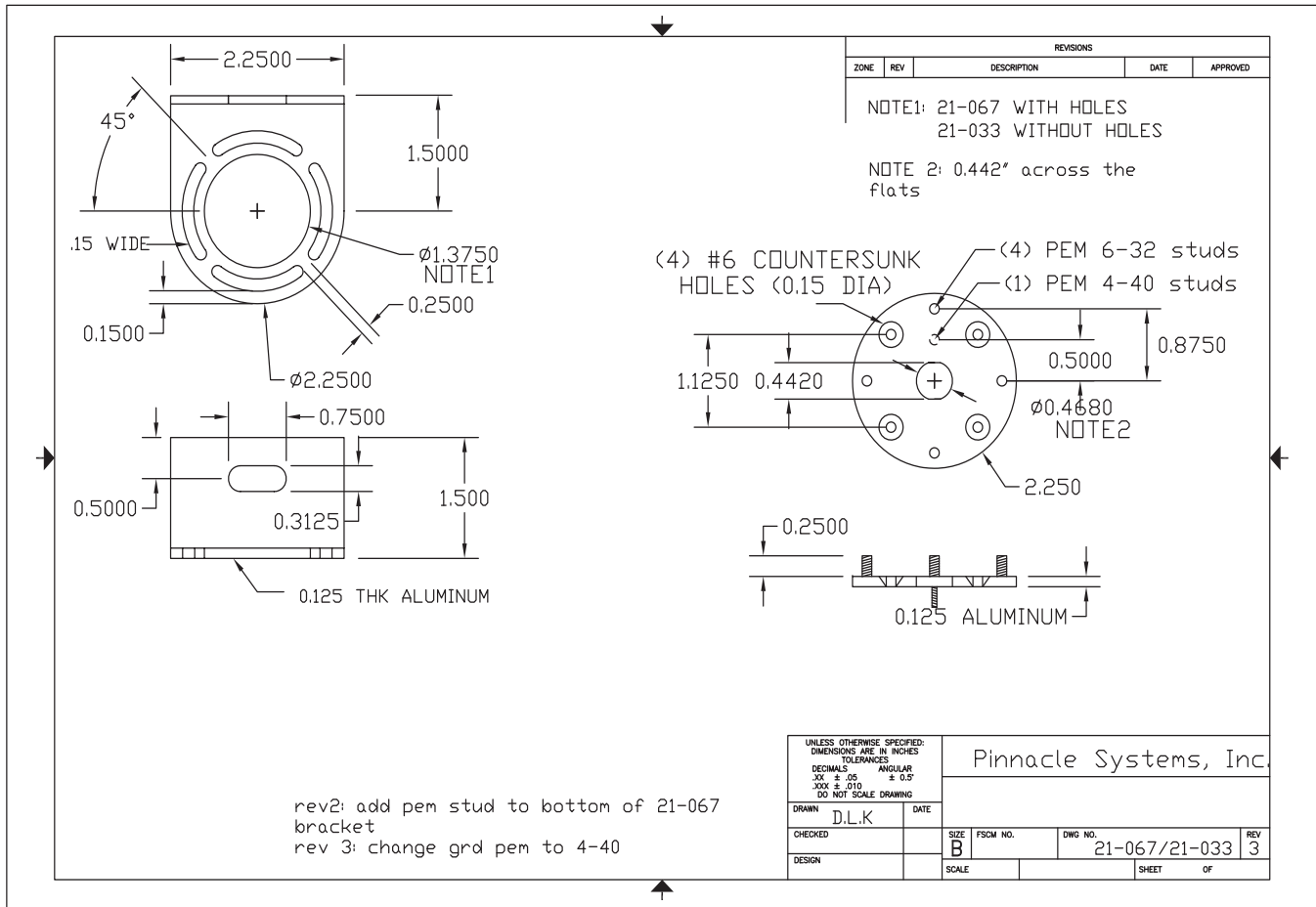

Pylon Dimensions

Figure 9: Swivel Bracket Dimensions, pylon dimensions (by model), and additional cable information

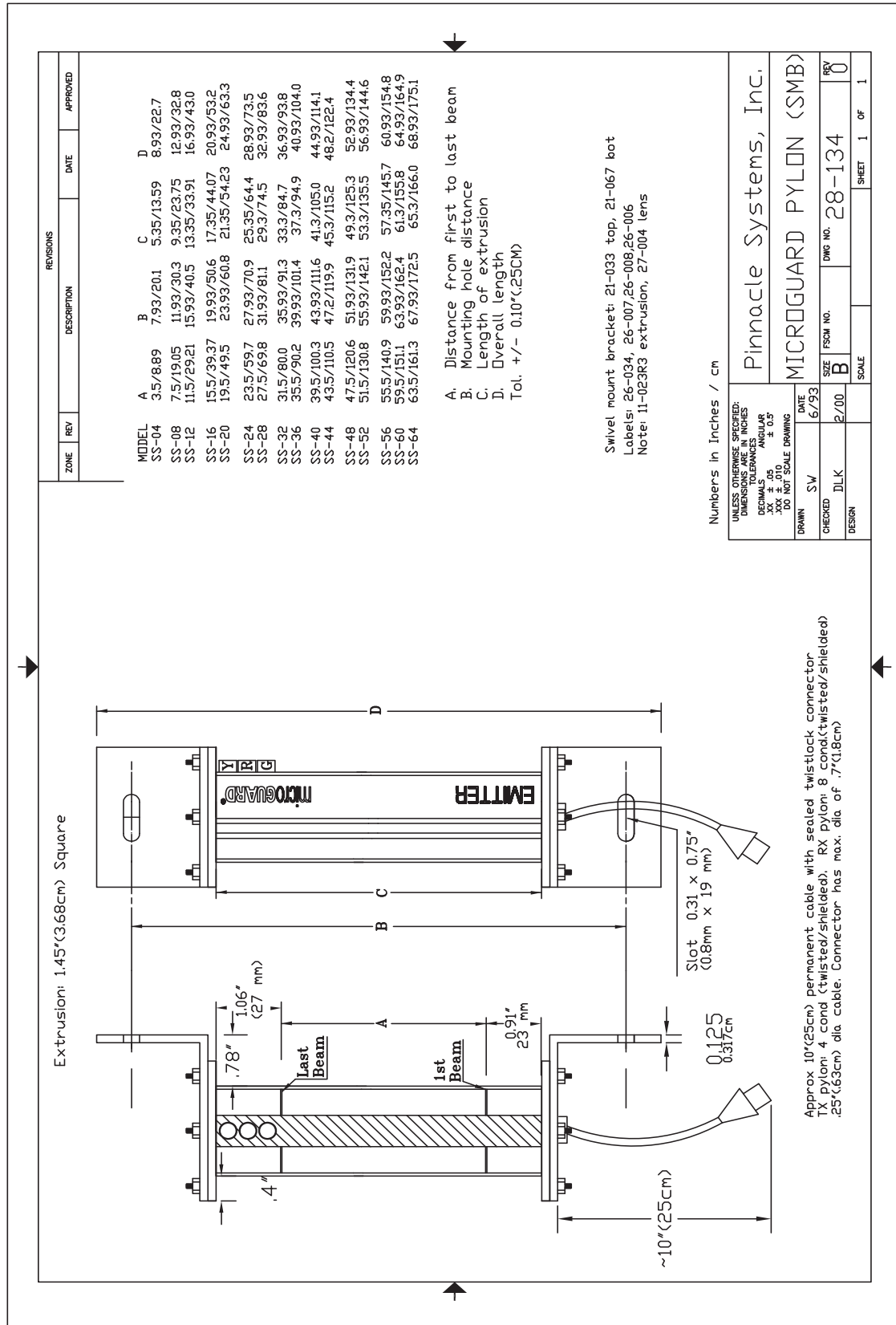

# Dimensions

## Model CA Cascading Safety Light Curtain

### Pylon Dimensions

Figure 10: Swivel Bracket Dimensions CE, pylon dimensions (by model), and additional cable information

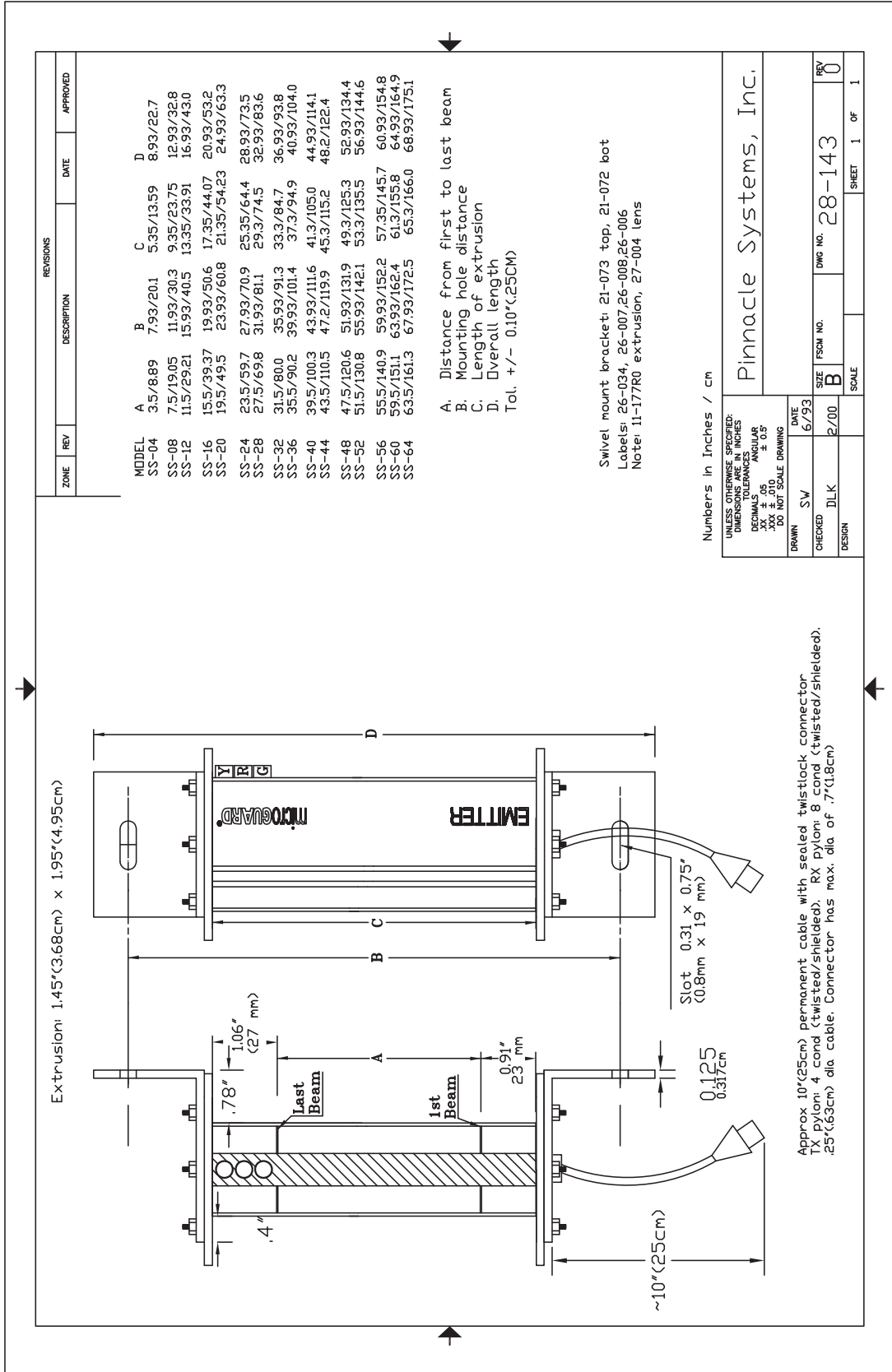



Pylon Dimensions

Figure 11: Fixed Bracket Dimensions, pylon dimensions (by model), and additional cable information

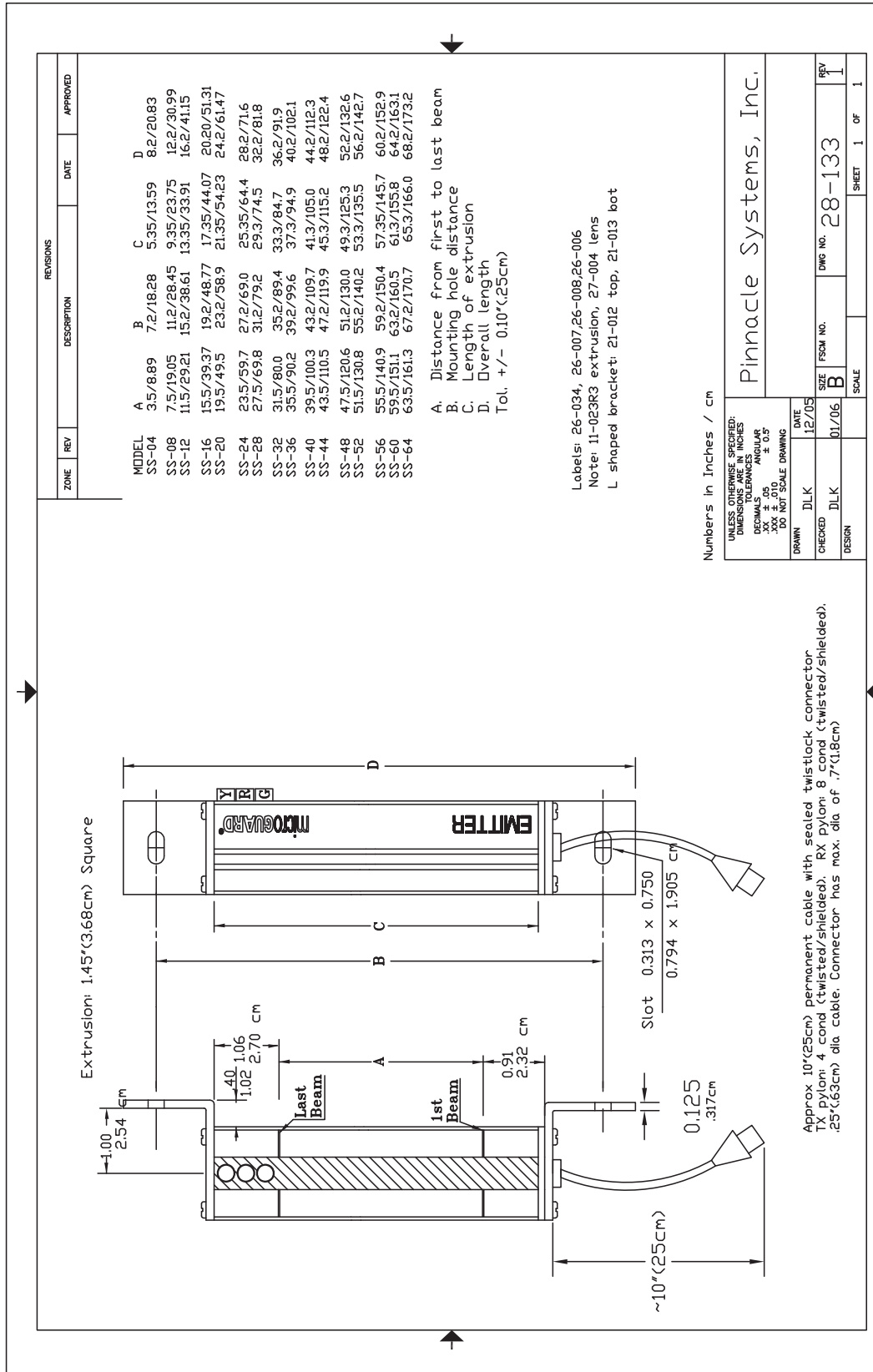

# Dimensions

## Model CA Cascading Safety Light Curtain

### Remote Status Display (RSD)<sup>TM</sup>

**Figure 12a: Remote Status Display - Auto Blank or Floating Blank**

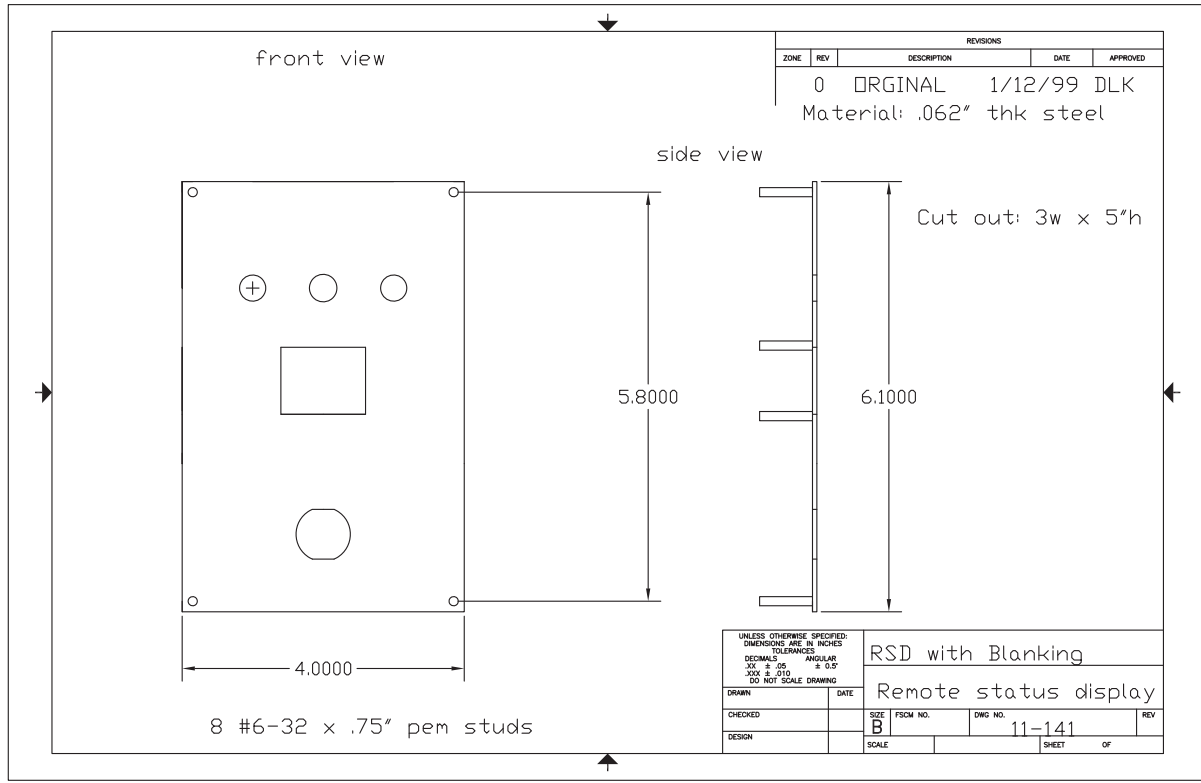

**Figure 12b: Standard Remote Status Display - No Blanking**

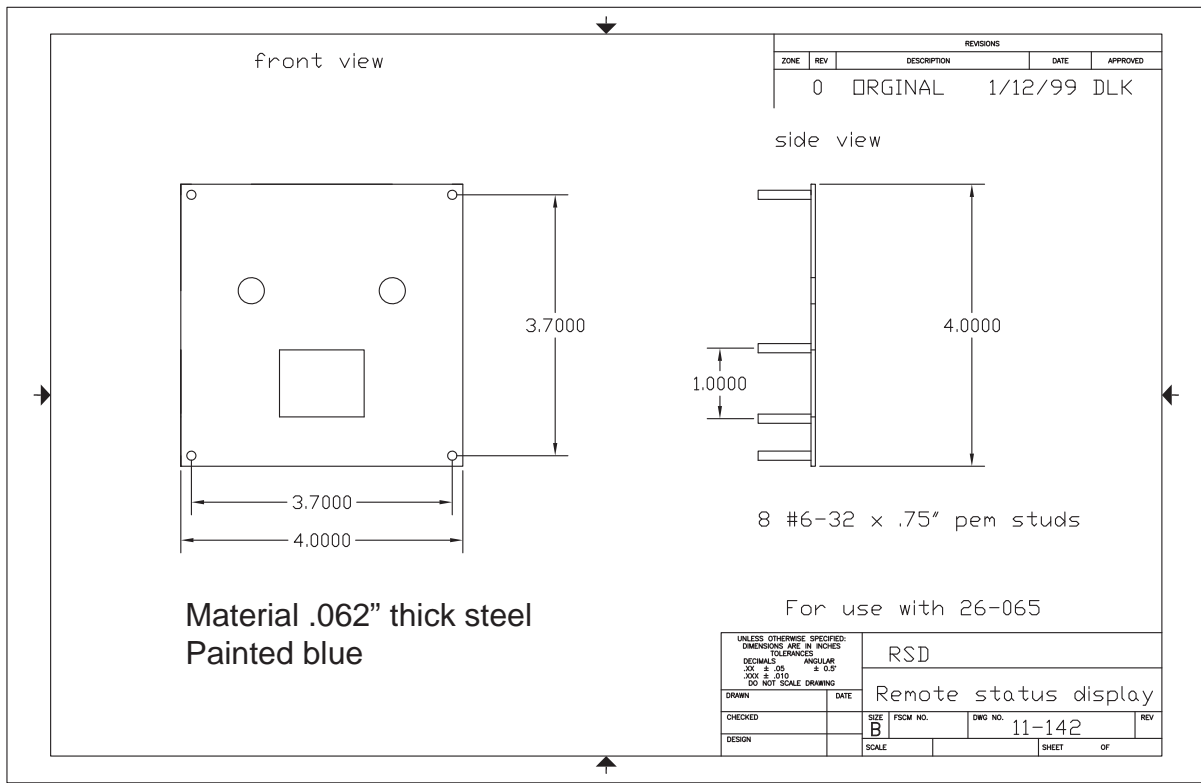

### Solid State Safety Relay Interface



**Part # SSSR**

- Base device to IEC 60204-1 and EN 954 -1 for two-channel emergency stop monitoring.
- Category 4 to EN954-1
- Stop category 0 to EN 60204-1
- Manual or automatic start
- Feedback circuit for monitoring external contactors
- 3 enabling current paths, NO contacts, positively driven
- For processing signals from the output signal switching devices (OSSD) of a light curtain acc. to DIN EN 61496-1
- Input debouncing (light curtain application)
- Power-on reset (without starting lockout)

### Description of Device and Function

This device is a two-channel safety switching device for emergency stop applications with self-monitoring on each ON-OFF cycle. It conforms to EN 60204-1 and is equipped with positively driven relays.

Basic function: After supply voltage has been connected to terminals A1/A2 and the safety inputs closed, operating the reset button closes the enabling current paths (manual start). When the safety inputs are opened/de-excited the enabling current paths will open.

### Operating modes / system functions

- Without cross monitoring Both safety channels are connected to positive potential (S12 and S31 to S11).
- Manual start When the safety inputs are closed, a button is used to open reset input S34 (triggering with falling edge) or to close reset input S35 (triggering with rising edge).
- Automatic start Reset input S35 is connected to S33. The device starts with the rising edge of the signal on safety input S12.
- Starting lockout After supply voltage has been connected and the safety inputs closed, the enabling paths will not close. Starting is only possible after the reset button has been operated. For starting lockout the reset inputs have to be activated with the button, as in manual start mode.
- Restarting lockout No restart after the safety inputs have been opened and closed. Restarting is only possible after the reset button has been operated. For restarting lockout the reset inputs have to be activated with the button, as in manual start mode.
- OSSD-compatible OSSD signals from a light barrier or other safety sensors with semiconductor outputs can be processed. Test pulses  $< t_{TP}$  do not influence the device functions. Test pulses  $> t_{TP}$  can lock the device.
- Synchro-check With two-channel activation both safety channels are monitored together with synchronous time  $t_S$ . Safety channel CH1 must close before CH2 and bridge S33/S35 must be connected. If CH2 closes before CH1, the synchronous time

$t_S = \infty$ .

# Safety Relay Module

For use with the Model CA OSSD Outputs 1 & 2

## Proper Use

The devices are safety switching devices. They must only be used as components of safety equipment on machines intended to protect persons, material and plant.

### Notes

- The safety category according to EN 954-1 depends on the external circuitry, the choice of control devices and their location on the machine.
- The indicated times must be observed when the device is operated, otherwise the device could lock. Locking can be cancelled by opening the safety inputs properly.
- SNE expansion devices or external contactors with positively driven contacts can be used to duplicate the enabling current paths.
- The device and the contacts must be protected at maximum 6 A utilization category gG.
- The devices are equipped with overload protection (for short-circuit). After the malfunction has been dealt with, the device is operational again in approximately 3s.
- Control output S11 is exclusively for connecting control devices as defined in the operating instructions and not for connecting external consumers such as lamps, relays or contactors.
- The devices must be installed in a cabinet with a protection class of at least IP 54.

Table 3: Function Diagram

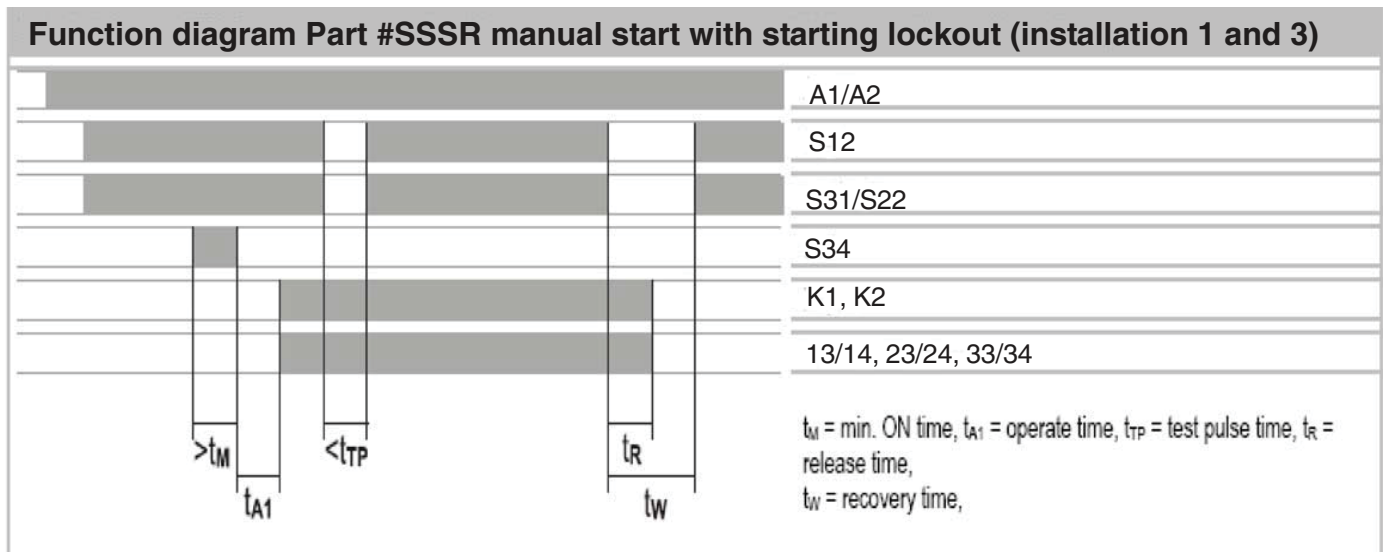

# Safety Relay Module

For use with the Model CA OSSD Outputs 1 & 2

## Installation

Figure 13: Installation Pressure (Electrical)

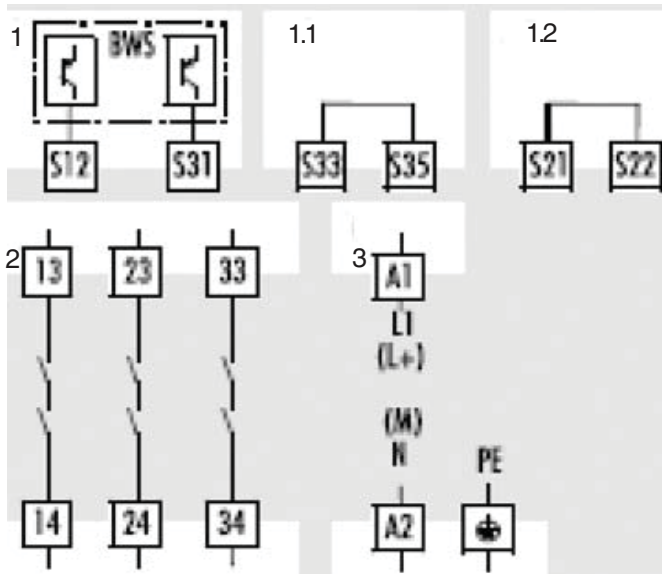

Please consult the connection diagram during installation.

1	<b>OSSD actuation</b> two-channel, automatic start , without cross monitoring (for DC devices)
1.1	Bridge
1.2	Bridge
2	<b>Enabling current paths</b> 3 NC contacts, positively driven
3	<b>Supply voltage</b> (PE or AC devices only)

Figure 14: Installation Pressure (Electrical)

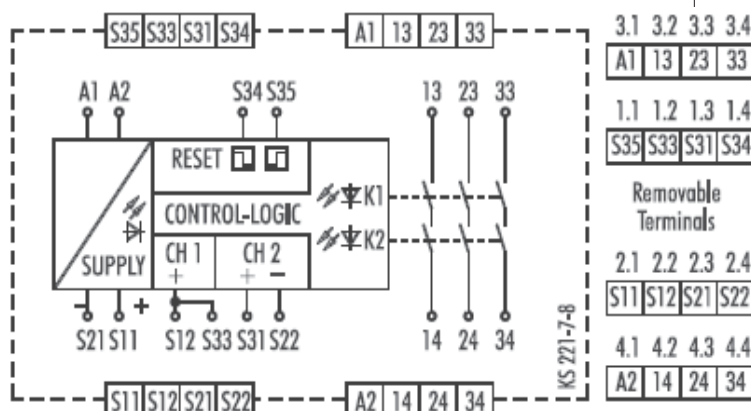

Removable Terminals only on devices with style - A (plug-in terminals)

Table 4: Safety Relay Wiring Table

Terminal	Description	Connect to	Wire Color
A1	+Supply input	+24v power	Red
A2	-Supply input	Ground	Black
PE	Earth		
S12	Ch1 input	CA Output 1	Blue
S31	Ch2 input	CA Output 2	Brown
S22	Ch2 input	S21	
S35	Auto Reset	S33	
S35	Manual Reset	thru N.O. push button to S33	
13-14	N.O. (held closed) output	Stop circuit 1	
23-24	N.O. (held closed) output	Stop circuit 2	
33-34	N.O. (held closed) output	Stop circuit 3	

**NOTE:** You must use at least 2 output STOP circuits. If your machine has only 1 STOP circuit, you must wire 2 STOP circuits in series.

# Safety Relay Module

For use with the Model CA OSSD Outputs 1 & 2

Table 5: Specifications

Technical data	
<b>Power circuitry</b>	<b>Part # SSSR</b>
Rated voltage UN	DC 12 V, AC/DC 24 V AC 115 - 120 V, AC 230 V
Rated power DC	DC 2.0 W
Rated power AC	AC 2.4 W / 4.4 VA
Residual ripple USS	2.4 V
Rated frequency	50...60 Hz
Operating voltage range	0.85...1.1 x UN
Protection for control circuit supply	Short-circuit-proof
<b>Control circuit</b>	
<b>Outputs (S11, S21)</b>	
Rated output voltage (S11 to S21)	DC 22 V
No-load voltage (AC devices only)	< 40 V
Output current	100 mA
Short-circuit-proof / current limiting	Yes / --
<b>Inputs (S12/S33, S31/S22, S34, S35)</b>	
Input voltage range (DC devices only)	DC 17.4 V to DC 26.4 V
Rated current / peak current (safety inputs S12/S33, S31/S22)	40 mA / 100 mA
Rated current / peak current (reset inputs S34, S35)	5 mA / 50 mA
Times	
Permissible test pulse time tTP / test frequency	≤1000 ms / ≤10 s-1
Operate time tA1 (reset input S34)	20 ms to 40 ms
Operate time tA2 (reset input S35)	200 ms to 600 ms
Operate time tA3	100 ms to 400 ms
Min. ON time tM (reset inputs S34, S35)	> 80 ms
Lock time tSP	
Operate time of lock tASP	---
Recovery time tW	≥ 100 ms
Release time tR (K1, K2)	< 25 ms
Synchronous time tS	≈ 0.2 s
<b>Output circuit</b>	
Enabling paths	
Contact equipment	3 NO contacts, positively driven
Rated switching voltage Un	AC 230 V / DC 300 V
Max. continuous current In per current path	6 A
Max. total current for all current paths AC 12 V, AC/DC 24 V	12 A
AC 115 - 120 V, AC 230 V	8 A
Utilization category according to IEC 947 - 5 - 1	AC-15: Ue 230 V, Ie 4 A (360 h-1) DC-13: Ue 24 V, Ie 4 A (360 h-1)
	AC-15: Ue 230 V, Ie 3 A (3600 h-1) DC-13: Ue 24 V, Ie 2.5 A (3600 h-1)
Mechanical service life (switching cycles)	10x10 <sup>6</sup>
<b>General data</b>	
Clearance/creepage distance between circuits	to DIN VDE 0110 Part 1: 04.97
Rated impulse withstand level	4 kV
Contamination level of device: inside / outside	2/3
Rated voltage	AC 300 V
Protection class to DIN VDE 0470 Part 1: housing / terminals	IP 40 / IP 20
Ambient / storage temperature	-25 ... +55 / -25 ... +75 °C
Weight	
DC device	0.21 kg
AC device	0.25 kg
<b>Terminals and connection</b>	
Single-core or finely stranded	1 x 0.14 mm <sup>2</sup> to 2.5 mm <sup>2</sup> 2 x 0.14 mm <sup>2</sup> to 0.75 mm <sup>2</sup>

# Safety Relay Module

For use with the Model CA OSSD Outputs 1 & 2

Stripping length	max. 8 mm
Finely-stranded with wire-end ferrule to DIN	46228 1 x 0.25 mm <sup>2</sup> to 2.5 mm <sup>2</sup> 2 x 0.25 mm <sup>2</sup> to 0.5 mm <sup>2</sup>
Max. tightening torque	0.5 to 0.6 Nm
For UL and CSA applications	
Conductor sizes	AWG 18-16 use only Cu lines
Max. tightening torque	0.79 in-lbs

Figure 15: Solid State Safety Relay Installation

### Assembly

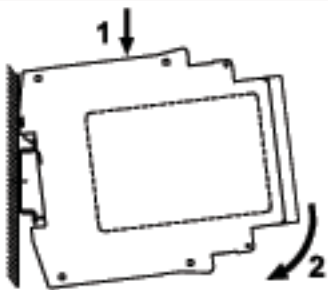

1. Attach device to DIN rail
2. Press carefully onto the DIN rail (in direction of arrow) until it locks into place.

### Disassembly

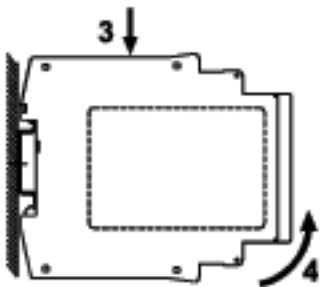

3. Push down (in direction of arrow)
4. Release and remove it from the DIN rail (see arrow)

### Dimension Diagram

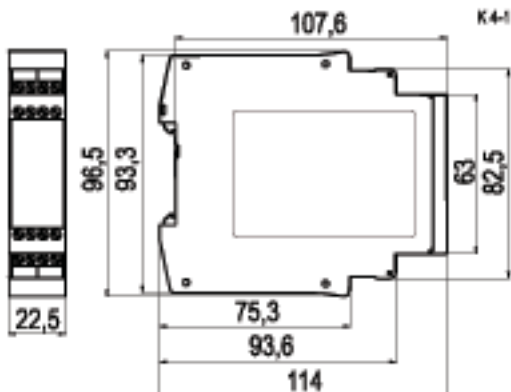

# Accessories

## Model CA Cascading Safety Light Curtain

### Cornering Mirrors

Through the use of cornering mirrors, multiple sides or work envelopes can be guarded which enhance safety and down-time related to mechanical and electrical interlock systems. Include a reflectivity loss per mirror (15% for MGM, 10% for TRM) when calculating total scanning distance of light curtain.

**NOTE:** Mirrors are surface coated. Wipe surface using only a damp, clean, soft 100% cotton cloth. To replace broken or scratched glass, remove end bracket and slide mirror out with gasket.

**WARNING:** If you are using Auto Blank or Floating Blank options, you may unknowingly create a hole around your machine. Do not use mirrors with blanking unless you need blanking on all guarded sides.

**Table 6: Cornering Mirror Dimensions**

MODEL	DIM A (in/mm) (hole to hole distance)	DIM B (in/mm) (mirror length)	DIM C (in/mm) (total length)
TRM-04 / MGM-04	7.45 / 189	6.25 / 159	8.50 / 216
TRM-08 / MGM-08	11.45 / 240	10.25 / 260	12.50 / 318
TRM-12 / MGM-12	15.45 / 392	14.25 / 362	16.50 / 419
TRM-16 / MGM-16	19.45 / 494	18.25 / 464	20.50 / 521
TRM-20 / MGM-20	23.45 / 494	22.25 / 565	24.50 / 622
TRM-24 / MGM-24	27.45 / 697	26.25 / 667	28.50 / 724
TRM-28 / MGM-28	31.45 / 799	30.25 / 768	32.50 / 826
TRM-32 / MGM-32	35.45 / 900	34.25 / 870	36.60 / 927
TRM-36 / MGM-36	39.45 / 1002	38.25 / 971	40.50 / 1029
TRM-40 / MGM-40	43.45 / 1104	42.24 / 1073	44.50 / 1130
TRM-44 / MGM-44	47.45 / 1208	46.25 / 1175	48.50 / 1232
TRM-84 / MGM-48	51.45 / 1307	50.25 / 1276	52.50 / 1334
TRM-52 / MGM-52	55.45 / 1408	54.25 / 1378	56.50 / 1435
TRM-56 / MGM-56	59.45 / 1510	58.25 / 1480	60.50 / 1537
TRM-60 / MGM-60	63.45 / 1612	62.25 / 1581	64.50 / 1638
TRM-64 / MGM-64	67.45 / 1713	66.25 / 1683	68.50 / 1740

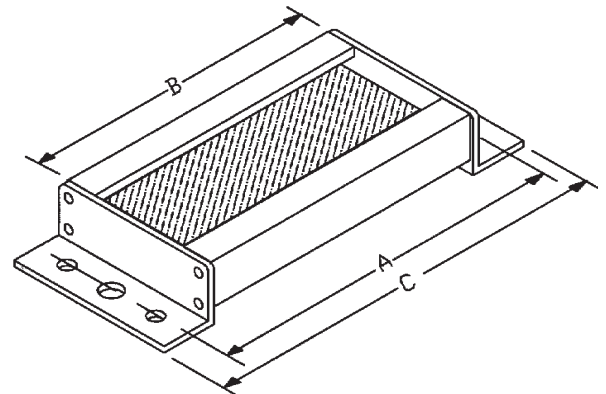

Tolerance: +/- 0.10 inches / .025cm

**Figure 16: Cornering Mirror Dimensions**

#### MGM Dimensions

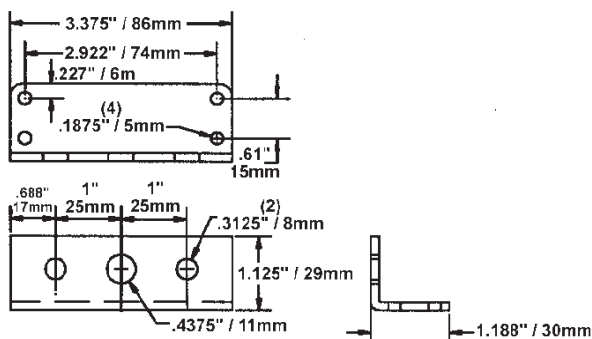

#### TRM Dimensions

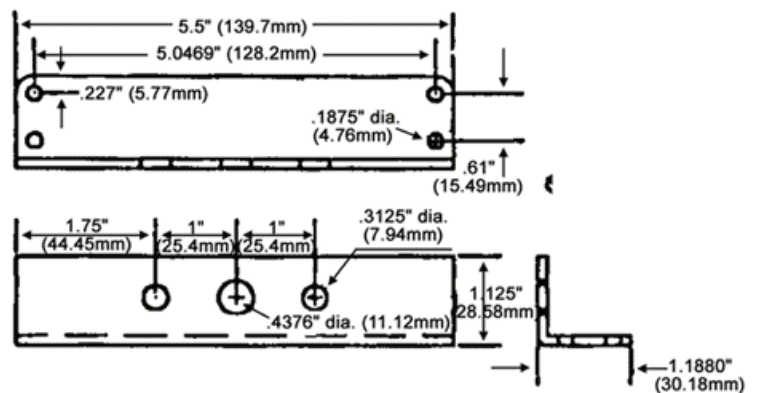



## Pedestal Mounting

The heavy duty, all-welded steel pedestal floor mounts can be used for mounting either the MicroGuard Metal Box or DIN-rail Controller Module or cornering mirrors. Sliding mounts on the pedestal are universal in design and are supplied standard. Unique floating base on pedestal is designed to compensate for uneven floors. Pedestal is fabricated from 12 gauge steel, the base is 1/4" steel plate, and the entire unit is painted OSHA yellow.

Standard height = 72" (model 8000)

Optional height = 96" (model 8096)

NOTE: Do not mount pedestal to floor until you have fully installed your guarding system and know it is operating properly in its current position on the floor.

**WARNING:** Pedestals must be bolted to the floor after installation; they must not be movable.

- 11-183** Standard Single pedestal mounting bracket
- 11-184** Special Dual pedestal mounting bracket. Has two mounting studs 90deg apart. Allows both Emitter and Receiver pylon on one pedestal. Requires SMB option on pylons.

## Swing-Arm Mounting Bracket

Excellent method of mounting the light guard for press brakes or when the light guard is to be moved for die setups or machine maintenance. Model 9000 consists of three 180-pivot points along with light guard diagonal movement capability for virtually unlimited light guard positioning. Two-inch square tubing 3/16" thick painted OSHA yellow which mounts directly onto the machine housing and makes for a heavy duty yet versatile mounting bracket.

Specify dimensions for sections "B" and "C."

Figure 17: Pedestal Dimensions

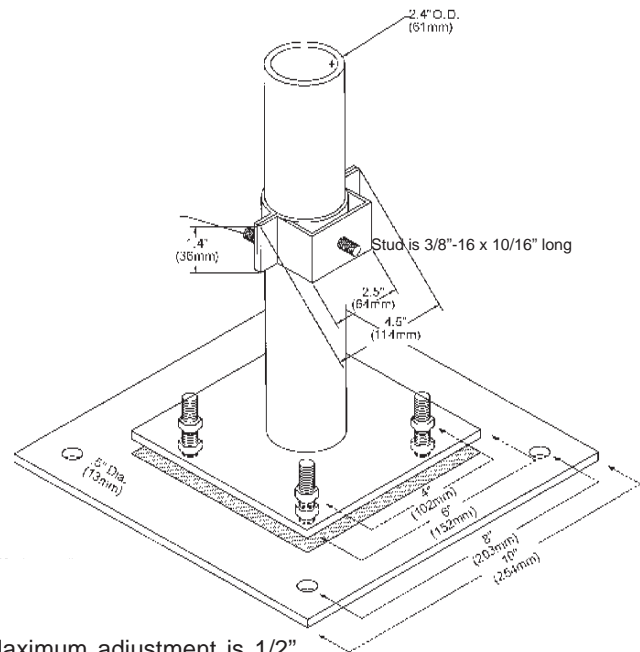

Maximum adjustment is 1/2" (13mm) vertical on four 3/8" (10mm) x 1.5" (38mm) bolts.

Pedestal is square.

All dimensions are the same on the x and y axis.

Figure 18: Swing-Arm Mounting Bracket

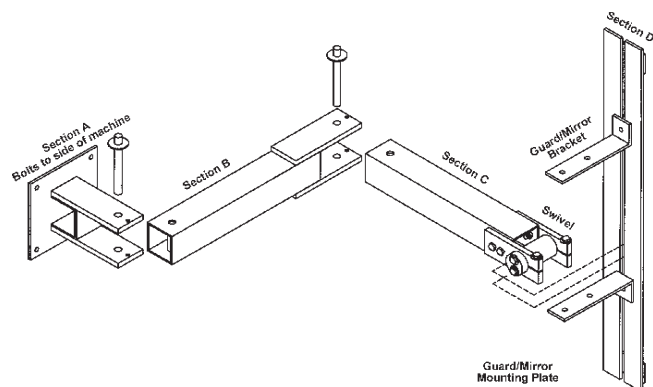

## Appendix "A"

### Diagnostics & Troubleshooting Model CA Cascading Safety Light Curtain

Flashing LED(s) indicate a fault has occurred. To find the fault you must count the number of flashes. If multiple faults have occurred, the lowest number flashed first, followed by the next higher number, after the last fault is flashed the cycle starts over again.

**NOTE:** The "Remote Status Display" will show the actual fault message instead of flashing LEDs.

**Problem:** Yellow LED is ON steady on Emitter pylon. Red LED flashes every few seconds.

**Solution:** The CAN data lines (white & green wires) from both RX and TX pylons are not connected together.

The CA guard has gone into bottom beam synchronization mode where the RX and TX pylons do not need to be wired together.

**Problem:** No output on 1 or both of the Safety Outputs (blue and/or brown wires) are not reading 24vdc when the guard is GREEN.

**Solution:** Check RX pylon wiring. Check RX pylon internal fuse. Allow unit to cool down, remove Outputs

**Table 7a: Emitter Pylon Master**

EMITTER PYLON (Master CPU)		
Flashes (GRN LED)	RSD Message	Description
1	MTX Length Fault	Master Emitter length of pylon appears too short for what's programmed into the computer board. Problem in Emitter pylon.
2	MTX Length Fault	Master Emitter length of pylon appears too long for what's programmed into the computer board. Problem in Emitter pylon.
3		
4	MTX Open LED fault 1	Master Emitter found OPEN in LED OFF when it should be ON
5	MTX Open LED fault 2	Master Emitter found OPEN in LED ON when it should be OFF
6	MTX Short LED fault 1	Master Emitter found Short in LED when ON
7	MTX Short LED fault 2	Master Emitter found Short in LED when OFF
8	MTX M/S not in SYNC	Master Emitter CPU cannot SYNC up with Slave CPU. Problem in Emitter computer board.
9	MTX M/S Cannot talk	Master Emitter CPU cannot talk with Slave Emitter CPU. Problem in Emitter computer board.
10	MTX No CAN with RX Pylon	Master Emitter lost CAN (White & Green) data connection with Receiver pylon.
11	CAN error at startup	
12		
13		
14		
15		

**Table 7b: Emitter Pylon Slave**

EMITTER PYLON (Slave CPU)		
Flashes (YEL LED)	RSD Message	Description
<b>Solid on</b>	No CAN connected	The CAN (White/Green) data network appears to have no connection. The RED LED on the Emitter pylon will flash 1 time every few seconds to indicate life. The Emitter pylon has gone into Bottom Beam synchronization to communicate with the Receiver pylon. If you have connected the White & Green wires between the Emitter and Receiver pylons, then there is a problem.
1	STX Length Fault	Slave Emitter length of pylon does not match the programming of the computer board. Problem in Receiver pylon.
2	STX G Fault	Emitter LED's not firing correctly. Emitter pylon fault.
3		
4	STX CLK line Fault	Slave Emitter CPU timed out waiting for clock signal from Master. Check Emitter computer board.
5	STX Open LED fault 3	Slave Emitter found OPEN in LED. Check Emitter pylon.
6	STX Short LED fault	Slave Emitter found SHORT in LED. Check Emitter pylon.
7	STX M/S bad data	Slave Emitter CPU cannot talk with Master Emitter CPU. Problem in Emitter computer board.
8	STX M/S Cannot talk	Slave Emitter CPU cannot talk with Master Emitter CPU. Problem in Emitter computer board.
9	STX MST never started	Slave Emitter CPU never completed power up initialization routine properly. Problem in Emitter computer board.
10		
11		
12		
13		
14		
15		

# Appendix "A"

## Diagnostics & Troubleshooting Model CA Cascading Safety Light Curtain

**Table 8a: Receiver Pylon Master**

RECEIVER PYLON (Master CPU)		
Flashes (GRN LED)	RSD Message	Description
1	MRX Length Fault	Master Receiver length of pylon does not match the programming of the computer board. Problem in Receiver pylon.
2	MRX Receiver Fault	Master Receiver circuitry is faulty. Problem in Receiver pylon.
3	MRX K1-K2 Output Short	Master Receiver circuitry is faulty. Solid-State outputs (Blue & Brown wires) appear to be shorted together.
4	MRX TX N/A Fault	
4	MRX No CAN with TX Pylon	Master Receiver appears connected to the Emitter pylon, but cannot communicate with it. Check Cable, Check Emitter pylon.
4	MRX CAN Trans Fault	
4	MRX CAN Corrupted	Master Receiver appears connected to the Emitter pylon or RSD, but cannot communicate with it. Check Cable, Check Emitter pylon. Check RSD. If both Receiver & Emitter pylons appear to function normally, then the RSD is at fault.
5	MRX Infrared Detected	Master Receiver has detected external infrared signals from another source besides its own Emitter pylon. Check for external Infrared sources, if none, then repair Receiver pylon.
6	MRX K2 stuck OFF	Master Receiver solid-state output K2 is not turning on when commanded too. This output is 0.5A max. Check load on output Brown wire. There is an internal automatically resetting thermal fuse.
7	MRX K2 stuck ON	Master Receiver solid-state output K2 is not turning off when commanded too, or external voltage has been applied to this output. Check wiring of Brown wire. Check for parallel wiring on the Brown wire.
8	MRX M/S Cannot talk	Master Receiver CPU cannot talk with the Slave Receiver CPU. Check computer board in Receiver pylon
9	Slave Length Fault	
10	Slave RX or Relay Fault	
11		
12		
13		
14		
15		

**Table 8b: Receiver Pylon Slave**

RECEIVER PYLON (Slave CPU)		
Flashes (YEL LED)	RSD Message	Description
1	SRX Length Fault	Slave Receiver length of pylon does not match the programming of the computer board. Problem in Receiver pylon.
2	SRX Receiver Fault	Slave Receiver circuitry is faulty. Problem in Receiver pylon.
3		
4	Clock line fault	Slave Receiver CPU timed out waiting for clock signal from Master. Check Receiver computer board.
5	RX on at wrong time	
6	SRX K1 stuck OFF	Slave Receiver solid-state output K1 is not turning on when commanded too. This output is 0.5A max. Check load on output Blue wire. There is an internal automatically resetting thermal fuse.
7	SRX K1 stuck ON	Slave Receiver solid-state output K1 is not turning off when commanded too, or external voltage has been applied to this output. Check wiring of Blue wire. Check for parallel wiring on the Blue wire.
8	Cannot talk to Master CPU	Slave Receiver CPU cannot talk to the Master Receiver CPU. Check computer board in Receiver pylon.
9	SRX MST/SLV not in SYNC	Slave Receiver CPU timed out waiting for SYNC signal from Master. Check Receiver computer board.
10		
11		
12		
13		
14		
15		

## OSHA Regulations

### **1910.217 (C) (3) (iii) Safeguarding the Point of Operation**

(iii) A presence sensing point of operation device shall protect the operator as provided in paragraph (c) (3) (i) (a) of this section, and shall be interlocked into the control circuit to prevent or stop slide motion if the operator's hand or other part of his body is within the sensing field of the device during the downstroke of the press slide.

- (a) The device may not be used on machines using full revolution clutches.
- (b) The device may not be used as a tripping means to initiate slide motion.
- (c) The device shall not be constructed so that a failure within the system does not prevent the normal stopping action from being applied to the press when required, but does prevent the initiation of a successive stroke until the failure is corrected. The failure shall be indicated by the system.
- (d) Muting (bypassing of the protective function) of such device, during the upstroke of the press slide, is permitted for the purpose of parts ejection, circuit checking, and feeding.
- (e) Refer to ANSI B11.19-2003 for calculating safety light curtain distance from the point of operation.
- (f) Guards shall be used to protect all areas of entry to the point of operation not protected by the presence-sensing device.

### **1910.217 (C) (3) (iii) Additional requirements for safeguarding**

Where the operator feeds or removes parts by placing one or both hands in the point of operation, and a two hand control, presence sensing device or Type B gate or movable barrier (on a part revolution clutch) is used for safeguarding:

- (i) The employer shall use a control system and a brake monitor which comply with paragraphs (b) (13) and (14) of this section.
- (e) Inspection, maintenance, and modification of presses-
  - (i) It shall be the responsibility of the employer to establish and follow a program of periodic and regular inspections of his power presses to insure that all their parts,

auxiliary equipment, and safeguards are in a safe operating condition and adjustment. The employer shall maintain records of these inspections and maintenance work performed.

### **1910.212 General requirements for all machines (covers press brakes, hydraulic and pneumatic machines not covered by mechanical power press standards).**

- (a) Machine guarding - (1) Types of guarding. One or more methods or machine guarding shall be provided to protect the operator and other employees in the machine area from hazards such as those created by point of operation ingoing nip points, rotation parts, flying chips, and sparks. Examples of guarding methods are: barrier guards, two-handed tripping devices, electronic safety devices, etc.

NOTE: These are only partial reprints, refer to your Federal Register for total construction, control reliability, and machine guarding requirements for the subject machine being guarded for all applicable OSHA Standards.

## Machine Control Reliability Requirements

### **Control Reliability**

"...control circuits shall be designed and constructed so that a single failure or fault within the system does not prevent the normal stopping action from being applied to the press when required, or does not create an unintended stroking action, but does prevent initiation of a successive stroke until the failure is corrected" (ANSI B11.1-1988).

"...control shall be designed to prevent initiation of a stroke signal in the event that a failure occurs within the press control" (ANSI B11.2-1982).

"Robots shall be designed and constructed so that any single, reasonably foreseeable failure will not cause hazardous motion of the robot" (ANSI/RIA R15.06-1991).

"...control circuits shall incorporate features to minimize the possibility of an unintended stroke in the event of the failure of the control component to function properly, including relays, limit switches, and static output circuits" (ANSI B11.1-1982).

# Appendix "B"

## Regulations and Guidelines

### Model CA Cascading Safety Light Curtain

"...control system shall be constructed so that a failure within the system does not prevent the normal stopping action from being applied to the press when required, but does prevent initiation of a successive stroke until the failure is corrected" (ANSI B11.1-1982).

"...the control system shall be constructed so that a failure within the system does not prevent the normal stopping action from being applied to the press when required, but does prevent initiation of a successive stroke until the failure is corrected" (OSHA CFR 1910.217, 1988).

## Safety Guidelines for Management

### Operational Safety

1. Appoint a Safety Coordinator to be responsible for safety regulations, requirements, and suggestions. He must review and investigate all accidents and "close calls."
2. Establish and issue safety rules. Inform each employee of his responsibilities. Make sure he understands them and knows what is expected of him.
3. A thorough review and an early inspection must be made of existing presses, dies, and point of operation guarding to attain the degree of responsibility required by ANSI B11.1-1988 Safety Standards and Federal State laws. Review what mandatory modifications are necessary.
4. Equipment that is no longer safe and that cannot be economically upgraded should be destroyed.
5. Never allow persons legally under age to operate or assist in the operation of machinery.
6. All personnel must be properly trained to eliminate accidents and injuries.
7. Regardless of the operator's experience, education, or language barrier, it is the responsibility of the supervisor to give him a thorough explanation with each new job assignment.
8. No employee should be given a work assignment that he does not fully understand. Only properly instructed and thoroughly trained personnel should be assigned to work on or with any machine.
9. It shall be the responsibility of the employer to provide an adequate, clean, safe, and uncluttered work area around each machine.

10. If a malfunction is reported, stop the machine immediately, correct the problem, then resume production.
11. Investigate all accidents and close calls. Analyze the reason for occurrence. Take action to prevent recurrence. Keep records of the investigation and preventative steps that were taken.
12. Only employees who understand the machines, operation and safety requirements, and who are able to communicate this knowledge should be given the responsibility of instructing and training others to perform as operators.
13. Management must decide that personnel protective safety equipment is required to perform each job safely. Items such as safety glasses, shoes, gloves, helmets, hand pads, spats, protective sleeves and material handling equipment are common in the metal working industry. If noise levels are excessive, protective headsets and earmuffs are recommended.
14. When designing point of operation guarding, the manufacturing process should be weighed heavily in favor of operational safety.
15. Establish safe and convenient material handling methods and procedures.
16. Post in convenient areas the names, addresses, and phone numbers of physicians and hospitals, and members of the organization who are to be called in case of emergency.
17. All equipment must be electrically connected according to the National Electric Code and be consistent with other accepted practices.
18. Provide adequate and proper fire protection equipment.

### Power Press Guarding

1. Press manufacturers do not know and cannot foresee the magnitude of potential applications of power presses. Therefore, only the press user can determine the type of guards that have to be used in order to perform the job safely. It is the responsibility of the user management to make certain that point of operation guarding and other necessary safety devices are installed. The press should be guarded in such a manner that it is impossible for the operators to place their hands or any other part of the body in the die area.



2. The press user should become thoroughly acquainted with the safety devices commonly employed in power press operations.
3. Feeding devices are strongly recommended, since they remove the operator from the die area, and therefore allow more effective utilization of guards and safety devices.
4. Do not release a press for production before installing and testing all guards and covers.
5. Make frequent evaluation checks of all guarding and devices while the press is running. Correct all unsafe findings immediately.

#### **Power Press Care through Inspection and Maintenance**

1. All maintenance and inspection personnel should be specifically instructed, and must understand proper maintenance and inspection procedures contained in this manual.
2. Set up a daily, weekly, and monthly press inspection program. Use a checklist and verify that the job is done correctly.
3. Establish a preventative maintenance program. Records of all maintenance work performed must be kept.
4. Since all equipment has a limited life, quality maintenance personnel are required to obtain maximum usage of your equipment.
5. Releasing a power press for production following maintenance should be the responsibility of a qualified individual assigned by management.
6. To maintain the original level of press reliability, careful inspection of mechanical, electrical, and pneumatic areas must be made. This may give an advance warning of a hazard which then can be corrected to prevent possible injuries and damage.

#### **Safety Enforcement**

In order to have an effective safety program, management at all levels must enforce every safety rule and regulation. Strong disciplinary measures are sometimes required. They should consist of a warning, written reprimand, work suspension, transfer, demotion, or possibly a dismissal. All infractions must be reported and recorded. Once an infraction is noted, it shows that an unsafe practice or condition has existed. This may be the result of poor planning or improper training

and instructing. The reason for the infraction should be analyzed in order to take corrective action.

#### **Supervisor Training**

It should be the responsibility of management to instruct their supervisors on safety, giving job instructions, supervising operators, determining accident causes, and building safety attitudes among the machine operators. Accidents can occur due to inadequate training of supervisors.

#### **Operator Training**

It shall be the responsibility of management to insure proper training of operators. A specific training program should be instituted to instruct the operator in safety, proper usage of the equipment, and correct operational procedure in performing each and every job. In addition to the supervisor, the operator should be familiar with the proper guarding of the point of operation. Never permit an operator to start a job without complete instructions from his immediate supervisor.

---

## Appendix "C"

### Replacement Parts

### Model CA Cascading Safety Light Curtain

#### Pylons

<b>Part Number</b>	<b>Description</b>
52-254 (ref 31-092)	Receiver pylon computer board
52-255 (ref 31-095)	Emitter pylon computer board
52-272	Emitter cable, 1' pig-tail (4 cond male) Shielded
52-273	Emitter cable, 20' (4 cond female) Shielded
52-274	Emitter cable, 45' (4 cond female)
52-275	Receiver cable, 1' pig-tail (6 cond male)
52-276	Receiver cable, 20' (6 cond female)
52-277	Receiver cable, 45' (6 cond female)
52-260 (ref 31-097)	RSD computer board (for Model CA guards)
21-068	Cable Strain relief (for either Receiver or Emitter pylon)
21-007	Gasket (between bracket and pylon)
21-012	Top L shaped bracket
21-066	Bottom L shaped bracket (with grommet hole)
21-033	Top Swivel mount bracket
21-067	Bottom Swivel mount bracket (with grommet hole)
52-263	Standard pylon housing (painted with lens)
52-264	CE pylon housing (painted with lens)
27-004	Replaceable lens for either Standard or CE housing
32-097	Safety Relay Module (SSSR)
11-183	Standard Single pedestal mounting bracket
11-184	Special Dual pedestal mounting bracket. Has two mounting studs 90deg apart. Allows both Emitter and Receiver pylon on one pedestal. Requires SMB option on pylons.
20-022	1A Slo-Blo fuse
21-019	Rubber Shock-Mount (Male-Female) 1" dia x 1" tall 5/16-18 thread





# The road to your *Total Safety Solution*™ begins with Pinnacle Systems!

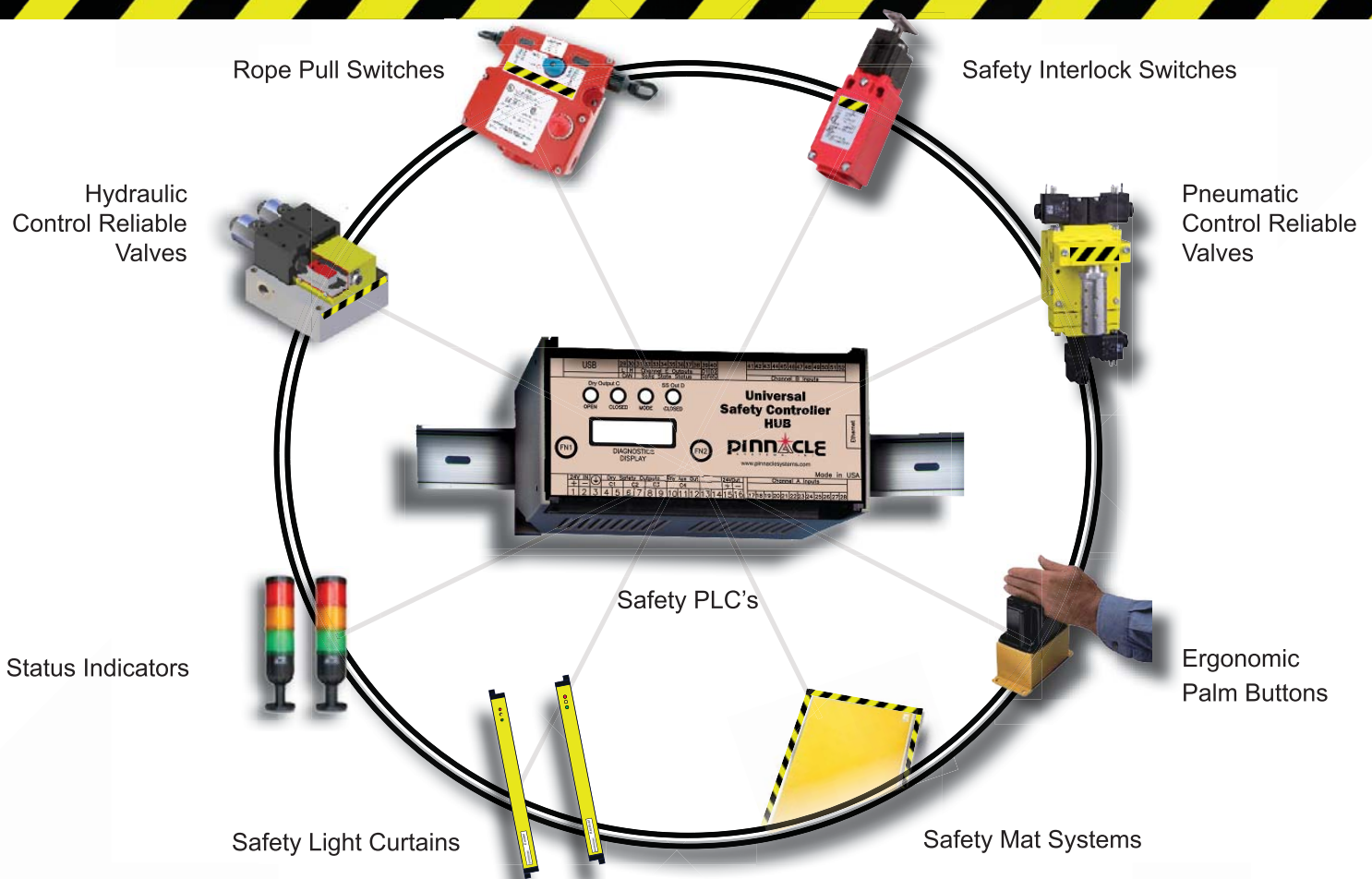

## Additional products to achieve your *Total Safety Solution*™!!!

- Safety Light Curtains
  - Model SS - Solid State Outputs
  - Model MG - Metal Box Controller
  - Model DR - DIN-Rail Controller
  - Model CA - Cascading Light Curtains
  - Model CE - Global Product (Solid State Outputs)
  - Model PPG - Perimeter Guarding
- Universal Safety Controller HUB / Safety PLC
- Safety Mat Systems and Controls
  - Area Guarding Systems
  - NSD Safety Mat Systems
  - STTS Safety Mat Systems
  - Direction of Travel Mats
  - High-Temp Welding Mats
- Ergonomic Palm Buttons
  - UltraTouch Palm Buttons
- Safety Interlock Switches (including explosion proof)
- Customized "control reliable" controls for dual solenoid activated pneumatic and hydraulic valve applications
- Energy Isolation and Single Point Lockout Systems
- Plant Surveys, Risk Assessment & Installation Services
- Customized Control Panels; Stainless Steel enclosures available for all products

### Punch Press / Metal Stamping Industry

- Resolver or Rotary Cam Based Clutch / Brake Controls - OSHA/ANSI Compliant
- Punch Press Automation Controllers
- Time-Based Brake Monitors
- Programmable Limit Switches
- Die Protection & Tonnage Monitoring Systems
- Servo Feed Interfaces

### Press Brake Guarding and Controls

- Press Brake Guarding for Mechanical, Air Clutch and Hydraulic Press Brakes
- Press Brake Control Systems



### **WARRANTY**

Manufacturer warrants that this product will be free from defects in material and workmanship for a period of two years from the date of shipment thereof. Within the warranty period, manufacturer will repair or replace such products which are returned to it with shipping charges prepaid and which will be disclosed as defective upon examination by the manufacturer. This warranty will not apply to any product which will have been subject to misuse, negligence, accident, restriction, and use not in accordance with manufacturer's instructions or which will have been altered or repaired by persons other than the authorized agent or employees of the manufacturer.

### **DISCLAIMER**

The provisions of the paragraph "Warranty" are the sole obligations of the manufacturer and exclude all other warranties of merchantability, expressed or implied.

Further, there are no warranties which extend beyond the above warranty.

### **LIMITATION OF LIABILITY**

In the event of any claim or breach of any obligations of manufacturer under any order, whether expressed or implied, and particularly in the event of any claim or a breach of the warranty or warranties contained in the paragraph "Warranty" or of any other warranties, expressed or implied which might, despite the paragraph entitled "Disclaimer," be determined to be incorporated in any order, the company shall under no circumstances be liable for any consequential or special damages, either in law or in equity, or for losses or expenses or claims for the same arising from the use of, or inability to use, the products of the manufacturer for any purpose whatsoever.

**WARNING:** The entire machine safety system must be tested at the start of every shift. Machine testing should include: (1) proper machine operation and stopping capability; and (2) verification of proper installation and settings of all point of operation guards and devices before the operation is released for production.



## **Sales and Marketing Offices**

### **United States**

Pinnacle Systems, Inc.  
P.O. Box 100088  
Pittsburgh, PA 15233

Toll Free Number: 800-569-7697  
Direct Number: 412-262-3950  
Fax: 412-262-4055

### **Canada**

Pinnacle Systems, Inc.  
8-1734 Orangebrook Court  
Pickering, Ontario L1W 3G8

Toll Free Number: 888-285-8885  
Direct Number: 905-831-1111  
Fax: 905-831-4064

## **Customer Service: (630) 443-8542**

We have designed our equipment to the very highest performance and safety standards known to the current technological state of the art, as evidenced by our U.S.A. and foreign patents issued and pending. However, the installation, usage, suitability, and fitness of our equipment for any purpose, known or unknown, is interdependent upon the performance of other equipment not manufactured, installed, secured or maintained by Pinnacle Systems, Inc.

We cannot and do not accept responsibility for any overall system performance when factors, such as these, are beyond our control.

**[www.pinnaclesystems.com](http://www.pinnaclesystems.com)**

**[sales@pinnaclesystems.com](mailto:sales@pinnaclesystems.com)**  
**[service@pinnaclesystems.com](mailto:service@pinnaclesystems.com)**