

# microGUARD<sup>®</sup>

## Installation Manual for the DIN-rail Controller Module



**Manual Revision History**

<b>Revision Number</b>	<b>Revision Date</b>	<b>Authorized Name</b>	<b>Description</b>	<b>Filename</b>
2.0	3/23/2001	LH	1. Eliminated 1" reference on Controller Jumper Chart 2. Updated Controller Module Wiring Table to include ESTOP references.. 3. Revamped entire manual with new format and added information	mg_din-rail_28-022r2.pdf
2.1	10/17/2001	DK/GK	Addition of new Warning paragraphs (warning page, installation page and back page)	mg_din-rail_28-022r2-1.pdf
2.2	3/11/2002	DK	Page 15: Changed emitter wiring Terminal #5 from Black/White to Blue	mg_din-rail_28-022r2-2.pdf
2.3	12/10/2002	DK	Page 17: Modified Graphic	mg_din-rail_28-022r2-3.pdf
2.4	5/6/2003	DK	Page 17: Modified Graphic	mg_din-rail_28-022r2-4.pdf
2.5	8/4/2003	DK	Appendix "C": Modified Receivers	mg_din-rail_28-022r2-5.pdf
2.6	2/19/2004	DK	Page 25: Added TRM Mirror Dimensions	mg_din-rail_28-022r2-6.pdf
2.7	3/2/2004	DK	Page 24: Added RSD Dimensions	mg_din-rail_28-022r2-7.pdf
2.8	4/14/2004	FGK	Object Sensitivity	mg_din-rail_28-022r2-8.pdf
2.9	4/21/2004	FGK	Fix Typo - Added Dpf Writing pg. 14	mg_din-rail_28-022r2-9.pdf
3.0	12/1/2004	DK	Page 15: Light Curtain Testing Procedure	mg_din-rail_28-022r3-0.pdf
3.1	5/4/2005	DK/AJR	1. Updated Figure 4 2. Removed Blank Pages	mg_din-rail_28-022r3-1.pdf
3.2	10/6/2005	DK	1. Updated Figure 9 and 10 2. Updated Tables 6-9	mg_din-rail_28-022r3-2.pdf
3.3	12/21/2005	DK	1. Revision of Figures 5 and 6 2. Addition of Figure 5a 3. Revision of Page/Table Numbers	mg_din-rail_28-022r3-3.pdf
3.4	1/4/2006	DK	1. Page 2: Fault Relay Output Paragraph 2. Table 5-e Terminal 11 Revision	mg_din-rail_28-022r3-4.pdf
3.5	4/19/2007	DK	Updated Figure 11	mg_din-rail_28-022r3-5.pdf
3.6	6/20/2007	DK	Page 7: Table 3 Revision	mg_din-rail_28-022r3-6.pdf
3.7	8/2/2007	DK	Page 2: External Relay Check Revision	mg_din-rail_28-022r3-7.pdf
3.8	9/12/2007	DK	1. Page 18: Figure 5b Revision - 28-139 2. Page 19: Figure 6 Revision - 28-138	mg_din-rail_28-022r3-8.pdf
3.9	6/4/2008	DK	1. Convert to Saddle Stitch  2. Revise Figure 5b and Figure 6 to Rev3	mg_din-rail_28-022r3-9.pdf
4.0	8/28/2008	DK	Page 2: Revise External Relay Check to match the diagram	mg_din-rail_28-022r4-0.pdf
4.1	7/23/2009	DK	1. Page A-4: Revise Serial data transfer incomplete 2. Revise total manual	mg_din-rail_28-022r4-1.pdf
4.2	8/6/2009	DK	1. Page 23: Add Bracket Part Numbers 2. Pages 1 and 3: Revised verbiage to state 4A@120vac recommended max	mg_din-rail_28-022r4-2.pdf
4.3	8/19/2010	DK	Page 8: Shock/Vibration Paragraph Addition	mg_din-rail_28-022r4-3.pdf



## **DIN-rail Controller Module Installation Manual**

**Pinnacle Systems, Inc.**  
3715 Swenson Avenue  
St. Charles, IL 60174

P/N: 28-022r4-3

**Customer Service: 630-443-8542 (CST)**  
(Please have Model #, Serial #, and Software Rev # Available)

Sales and Marketing: 800-569-7697 (EST)

[www.pinnaclesystems.com](http://www.pinnaclesystems.com) • [sales@pinnaclesystems.com](mailto:sales@pinnaclesystems.com) • [service@pinnaclesystems.com](mailto:service@pinnaclesystems.com)

## Proper Usage and Limitations

The information disclosed herein includes proprietary rights of the manufacturer. Neither this document nor the information disclosed herein shall be reproduced or transferred to other documents, used or disclosed to others for manufacturing purposes, or for any other purposes, except as specifically authorized in writing by the manufacturer. If this manual is supplied in connection with the sale or delivery of manufacturer's equipment, it is to be used solely for maintenance, repair, or installation of such equipment.

The MicroGuard was manufactured in the United States. The Installation Manual was printed in the United States.

You must read and fully understand the following information pertaining to the proper use and limitations of your Microguard:

- The MicroGuard must be installed by qualified personnel only.
- The MicroGuard must NOT be used on full revolution presses or any machine that cannot be commanded to stop at any time.
- You must NOT wire the Safety Output contacts of the MicroGuard to an external relay unless you use the External Relay Checking feature.
- The mechanical power press on which the MicroGuard is installed must meet ANSI B11.1-1988 and OSHA 1910.217 regulations. These include inspection and maintenance procedures that must be followed to comply with the regulations. The manufacturer will NOT take responsibility for improperly maintained machinery.
- Point of operation safeguarding is defined in ANSI B11.19-2003. This regulation is used to determine a safe distance to place your MicroGuard. The manufacturer takes no responsibility for injury as a result of improper safeguarding or improper safe distances.
- The MicroGuard may not be able to safely stop a press which has a faulty stopping mechanism. The manufacturer cannot be held responsible for an improperly maintained or faulty stopping mechanism.
- The MicroGuard must be checked before put into operation. Follow instructions provided in this manual for procedures on how to do this.
- The MicroGuard should never be modified or repaired except by qualified personnel and upon authorization of the manufacturer. Never operate machinery that is not in full working order.

- Make sure that all maintenance people, machine operators, die-setters, foreman, and supervisors have read and understood this manual and all procedures have been and will be followed.
- All procedures in this manual must be followed. The manufacturer cannot take responsibility for operation if all procedures and warnings in this manual are not followed.

## Warranty

Manufacturer warrants that this product will be free from defects in material and workmanship for a period of two years from the date of shipment thereof. Within the warranty period, the manufacturer will repair or replace (at our discretion) any product that is disclosed as defective upon examination by the manufacturer and is returned with shipping charges prepaid. This warranty will not apply to any product that has been subjected to misuse, negligence, accident, restriction, and use not in accordance with manufacturer's instructions or which will have been altered or repaired by persons other than the authorized agent or employees of the manufacturer.

## Disclaimer

The provisions of the warranty are the sole obligations of the manufacturer and exclude all other warranties of merchantability, expressed or implied. Further there are no warranties that extend beyond the above warranty.

## Limitation of Liability

In the event of any claim for breach of any obligations of the manufacturer under any order, whether expressed or implied, and particularly in the event of any claim of a breach of the warranty or warranties contained in the paragraph "Warranty" or of any other warranties, expressed or implied which might despite the paragraph entitled "Disclaimer," be determined to be incorporated in any order, the company shall under no circumstances be liable for any consequential or special damages, either in law or in equity, or for losses or expenses or claims for the same arising from the use of, or inability to use, the products of the manufacturer for any purpose whatsoever.

We have designed our equipment to the very highest performance and safety standards known to the current technological state of the art. However, the installation, usage, suitability, and fitness of our equipment for any purpose, known or unknown, is interdependent upon the performance of other equipment not manufactured, installed, or secured or maintained by the manufacturer. We cannot and do not accept responsibility for any overall system performance when factors, such as these, are beyond our control.

We will not supply individual component parts of any circuit board but will supply the individual circuit board complete. Individual detectors or emitters are available as a complete tested unit.

**WARNING:** The entire machine safety system must be tested at the start of every shift. Machine testing should include: (1) proper machine operation and stopping capability; and (2) verification of proper installation and settings of all point of operation guards and devices before the operation is released for production.

**FILL THIS INFORMATION OUT IMMEDIATELY**

Purchase Date: \_\_\_\_\_

Model No.: \_\_\_\_\_

Options: \_\_\_\_\_

Purchased From: \_\_\_\_\_

Serial No.: \_\_\_\_\_

Microprocessor Revision No.: \_\_\_\_\_

**This information will be needed in the event you need assistance.**



# Table of Contents

## Introduction

Theory of Operation .....	iv
The System.....	iv
System Safety.....	iv
Safety Features.....	iv

Specifications .....	1
----------------------	---

## Standard Features

Auxillary Relay Output .....	2
Emergency Stop Input .....	2
External Relay Check .....	2
Fault Relay Output.....	2
Resettable Latching Relays .....	2
MicroGuard DIN-rail Serial Port .....	3
Remote Latching Reset .....	3
Safety Relay Outputs.....	3

## Optional Features

Analog Output.....	5
Auto Blank.....	5
Cincinnati Interface .....	6
DeviceNet .....	6
Floating Blank .....	6
Guarding Mute-Out .....	7
Remote Diagnostics Display .....	7
Remote Indicator Lights .....	7
Remote Key Switch.....	7

## Installation Procedures

Resetting Faults .....	8
System Check.....	8
Aligning Pylons .....	9
Aligning Mirrors .....	9
Operations .....	10
ANSI Standard B11.19.2003.....	11
Safeguarding with Mechanical Guards .....	12
Light Curtain Test Procedure.....	12
Wiring.....	13
Controller Module Setup .....	16
Swivel Bracket Dimensions.....	17
Pylon Dimensions (by model) (Swivel) .....	18
Additional cable information (Swivel).....	18
Fixed Bracket Dimensions .....	19
Pylon Dimensions (by model) (Fixed).....	19
Additional cable information (Fixed).....	19

Dimensions	
Controller Module.....	20
RSD Mounting Dimensions.....	21
Accessories	
Cornering Mirrors.....	22
Pedestal Mounting.....	23
Swing-Arm Mounting Bracket.....	23
Appendix A: Diagnostics & Troubleshooting	
Obstruction or Misalignment.....	A-1
Error Conditions.....	A-1
Status Display Messages.....	A-2
Fault Display Messages.....	A-2
Appendix B: Regulations and Guidelines	
OSHA Regulations.....	B-1
Machine Control Reliability Requirements.....	B-1
Safety Guidelines and Management	
Operational Safety.....	B-2
Power Press Guarding.....	B-2
Power Press Care through Inspection and Maintenance.....	B-3
Safety Enforcement.....	B-3
Supervisor Training.....	B-3
Operator Training.....	B-3
Appendix C: Replacement Parts	
Pylons.....	C-1
Figures	
Figure 1: Mirror Alignment.....	9
Figure 2: Minimum Object Sensitivity and D(pf).....	11
Figure 3: DIN-rail Controller Module Wiring Diagram.....	15
Figure 4: Internal Circuit Board View.....	16
Figure 5a: Swivel Bracket Dimensions.....	17
Figure 5b: Swivel Bracket Dimensions, pylon dimensions (by model), and additional cable information.....	18
Figure 6: Fixed Bracket Dimensions, pylon dimensions (by model), and additional cable information.....	19
Figure 7: DIN-rail Controller Module Dimensions.....	20
Figure 8: RSD Plain Plate Dimensions.....	21
Figure 9: RSD Plate with Floating or Auto Blank Dimensions.....	21
Figure 10: Cornering Mirror Dimensions.....	22
Figure 11: Pedestal Dimensions.....	23
Figure 12: Swing-Arm Mounting Bracket.....	23

---

# Table of Contents

## Tables

Table 1:	DIN-rail Serial Port Diagnostics .....	4
Table 2a:	.5" Beam Spacing Pylons (Minimum Object Sensitivity, Depth Penetration Factor, Floating size) .....	6
Table 2b:	1" Beam Spacing Pylons (Minimum Object Sensitivity, Depth Penetration Factor, Floating size) .....	6
Table 3:	Truth Table .....	7
Table 4:	Mechanical Guards .....	12
Table 5a-f:	Controller Module Wiring .....	13
Table 6:	Internal Jumper Settings with Different Pylon Lengths .....	16
Table 7:	Cornering Mirror Dimensions .....	22



The MicroGuard DIN-rail Controller Module is an infrared safety light curtain that is designed to the European IEC 61496 standard. IEC-61496 standard defines requirements for infrared light curtains used in safety applications. When properly installed, it protects the machine operator by passing an invisible infrared light beam across an area to be guarded and examining whether or not the light beam(s) are blocked. If the light beams are blocked, safety outputs will automatically open up and a "ST OP" command will be sent to the guarded machine.

The system is composed of a sending unit (Emitter), a receiving unit (Receiver), and a Controller Module. The entire system is control reliable (per IEC 61496) in that a single fault anywhere within the MicroGuard DIN-rail itself will not prevent the safety outputs from opening up when anything blocks the infrared light beam(s). All failures are reported on the Diagnostics Display and/or via the RS-232 or RS-485 Serial Port.

The Diagnostics Display aids in installation by showing where beam blockage is occurring, as well as reporting selected installed options and fault reports.

**Theory of Operation.** The MicroGuard protects an area by projecting a curtain of infrared light. It forms a curtain by utilizing infrared Emitters in line on .5" or 1" centers. This close spacing makes it impossible to place a body part through the curtain without detection (assuming proper installation procedures were followed). For every infrared Emitter, there is an infrared Detector directly opposite. When an obstruction is placed between them, the beam is broken and the absence of a beam is observed by the Controller Module which de-energizes the safety relays and opens the connected circuit.

All the beams are scanned sequentially (one at a time) until the entire curtain has been scanned. The two computers compare data with each other every scan of the light curtain and will drop out the safety relays if any signal is incorrect or the compared data does not match. Cooperation from both computers is required to energize safety relays and either computer can disable both safety relays if a fault is detected.

**The System.** The MicroGuard employs infrared technology in a small sealed NEMA4 aluminum housing which provides harmless invisible protection and an unobstructed view of the guarded area. The Microguard consists of three parts: an Emitter pylon(s), Receiver pylon(s), and Controller Module. The Emitter pylon(s) contains infrared light emitting diodes spaced .5" or 1" apart down the entire length of the pylon. The Receiver pylon(s) contains an equal number of infrared detectors

and transistor receivers also spaced .5" or 1" apart. The Controller Module contains diverse redundant technology that includes two different microprocessors, self-checking circuitry, power supply, safety output contacts, and a diagnostics display.

**System Safety.** The MicroGuard employs diverse redundant technology that provides a backup for every system that could cause an unsafe condition. Upon power up, all systems are checked before activating the output relays. Once the unit passes the initial tests and activates the system, it is then tested by both microprocessors and other circuits once per scan of the light curtain. All signals are presented to both microprocessors, but are isolated from one another to prevent a failure of one microprocessor should the other crash. Other circuits detect short circuits, open circuits, proper voltage, proper oscillation, etc. The use of special dual force-guided safety relays assure that if one fails, the other can safely shut down the unit. Additionally, watchdog circuits on the relays prevent an unsafe condition even if both microprocessors failed. All the standard and optional features that run on the MicroGuard are designed with safety in mind:

The *Floating Blank* option allows only one object to be placed into the light curtain's field of view. Even if the object is smaller than the allowed size, a second object will cause the unit to go RED.

The *Auto Blank* option programs in the exact size and location of an object automatically and thus can detect any movement in the object and shut down the light curtain, which must be reset with a key.

The *External Relay Check* can detect either an opening or a short in the external relay or its wiring. The standard Cincinnati Interface provides a means to assure that the light curtain can open up its output relays between press cycles.

**Safety Features.** The MicroGuard was designed to meet the European IEC 61496 standard parts 1 and 2, CSA, UL 1998, UL Subject 491, OSHA, ANSI, and RIA.

- Control-reliable design prevents a failure to danger condition from ever occurring (assuming all installation procedures are followed properly).
- System redundancy assures that there are at least two ways to detect a system failure, two ways to shut down the safety outputs, and two safety outputs. The redundant systems are configured differently to prevent any possible inherent circuit

---

# Introduction

problems from occurring simultaneously in both redundant circuits.

- Force-guided relays allows dry relay contacts to be monitored for contact welding and/or circuit failure.
- Watchdog timers on both computers and both safety relays assures that a system lock-up will automatically drop out the safety relays.
- Through the use of shielded cables, chokes, surge suppressers, and optically-coupled inputs, immunity to EMI/RFI fields is greatly increased.
- The MicroGuard DIN-rail was designed to meet the European IEC 61496 standard parts 1 and 2 (part 2 requires use of optional 2 degree pylons), CSA, UL 1998, UL491, UL991, OSHA,ANSI, and RIA.
- Surface mount technology is used throughout for increased reliability.

**Input Power**

24vdc +/- 20% (7 watts max)

**Input Fuse**

1 amp fast blow (pico size)

**Relay Outputs**

K1, K2 Safety N.O.  
8A@250v resistive  
(4A@120vac recommended max)  
130V surge suppression devices are installed inside the Controller Module. This limits the recommended maximum voltage to 120VAC. Please consult factory if you need to switch higher voltages.

K3 Aux N.O. & N.C.  
8A@250v resistive  
(4A@120vac recommended max)

K4 Fault N.O.  
8A@250v resistive  
(4A@120vac recommended max)

**Indicators**

**External:**  
OK/CLEAR                      Green LED  
BLOCK/FAULT                 Red LED  
BLANKING ACTIVE            Yellow LED  
BLOCKED                        Red LED

**Internal:**  
D1 +5v        Yellow        D3 +12v       Red  
D14 K2 relay Green        D13 K1 relay Green  
D16 K3 relay Green        D15 K4 relay Green  
D19 +5v        Yellow        D18 -5v        Green

**Construction**

**Controller Module:** DIN-rail mountable polycarbonate housing providing IP40 protection, UL94V-1.

**Pylons:** Painted aluminum extrusion with polycarbonate IR lens and Viton seals providing NEMA 12, 13 protection. An optional polycarbonate tube provides NEMA 4 protection.

**Cables:** Shielded PVC 22 AWG stranded. Standard length: 20' Emitter; 8' Receiver

**Temperature Range**

0 to 50°C (up to 95% humidity, non-condensing)

**Dimensions**

**Controller Module:** 5.87" length X 2.95" width X 4.33" height DIN-rail mount is 35.5mm (1.4") wide.  
**Pylons:** 1.45" square.

**Beam Spacing**

.5" (12.7mm) standard  
1" [25.4mm] (optional). The Floating Blank option changes the effective beam spacing.

**Minimum Object Sensitivity:**

.5" (12.7mm) beam spacing is .55" (14mm)  
1" (25.4mm) beam spacing is 1.18" (30mm)

**Response Time** < 30 mSec total

**Scanning Frequency** 5.9 KHz

**Shock** Tested to withstand high vibration applications

**Self-Checking** every 20 milliseconds

**Scanning Distance** All units are supplied standard with a 20' scanning capability. Extended range units are available and must be specified (35' maximum).

**Maximum Operating Distance** Stated as last two digits in model number

# Standard Features

## DIN-rail Controller Module

### Auxiliary Relay Output

**Description:** Use this relay for horns, lights, and signals back to PLC's. Relay K3 is not monitored and driven off of the K2 relay. It should not be placed into a "stop" circuit by itself. Both N.O. and N.C. terminals are provided.

POWER / RELAY terminal #8: N.C., terminal #9: common, terminal #10: N.O. Follow the same directions as for contact ratings.

### Emergency Stop Input

**Description:** A built-in hardwired Emergency Stop Safety Input which utilizes two normally-closed emergency stop contacts to achieve a Category 4 safety level, per EN 954-1. If either or both emergency stop contacts open, power to the safety output relays is removed, causing the relays to de-energize and send a stop signal to the guarded machine.

**Application:** This protects against a safety switch contact failure or wiring fault. A contact failure or wiring short will inhibit the system reset, causing the system's Diagnostics Message Display to indicate an Emergency Stop Input failure.

**Usage:** See Figure 3 DIN-rail Controller Module Wiring Diagram for proper wiring of the E-Stop inputs. If you choose not to use this feature, you must still wire the two inputs closed (the DIN-rail is pre-wired from the factory). To reset an E-Stop fault, hit the F1 key on the top of the DIN-rail controller or Ground Terminal #3 on the Input/Output connector (the same input is used for the Latching Relay Reset).

### External Relay Check

**Description:** This feature allows the MicroGuard DIN-rail to monitor a pair of external relays in series. The external relays must be force-guided and have an extra pole that is normally closed. The primary pole of a force-guided relay maintains identical position to the secondary pole even when one of the poles is welded. The secondary pole is used to monitor your external relays.

**Application:** If your application requires you to switch to high current in your "stop" circuit, then you will need to use external relays. You will want to monitor those external relays in case of contact welding.

**To Activate Feature:** Install Jumper (see *Installation Procedures, "Controller Module Setup"*) on across pins labeled EXT. The display should read "rdyE" when this feature is active.

**Usage:** POWER / RELAY terminal #13: +pos input (+24vdc max), terminal #14: -neg input (ground)

The secondary poles must be N.C. when the curtain is

in a "RED" condition. The monitored external contacts must close and the primary contacts must open in a "RED" condition within 250mSec's or an error will occur. If the curtain is "GREEN," the monitored secondary contacts should open up and the primary contacts will close. An error will occur if the monitored contacts do not open up. The primary poles of your external relays must be N.O. (they are placed in your "stop" circuit). Bring +24vdc to Terminal #13, run GND through the N.C. contact of both external relays in series to Terminal #14.

**Messages:** (see *Appendix A: Diagnostics & Troubleshooting for details*)

"External contact welded or wire cut"

"External contact short"

NOTE: Use only shielded cable between external relays and external relay checking input.

### Fault Relay Output

**Description:** Relay K4 is not monitored and has its own driver circuitry. It should not be placed into a "stop" circuit by itself. The fault output is a dry contact N.O. (held closed when clear, opens when there is a fault). Use this relay for horns, lights, and signals back to PLC. POWER / RELAY terminal #11 & 12. Follow the same note found above for contact ratings.

### Resettable Latching Relays

**Description:** When power is applied to the MicroGuard DIN-rail unit, it will stay in a "RED" condition until the Latching Reset Input is reset.

**Application:** This is used for guarding an area against intrusion; without this feature the curtain would stay "RED" only as long as the curtain's field of view was blocked. If you are perimeter guarding, you may need this.

**To Activate Feature:** Install Jumper (see *Installation Procedures, "Controller Module Setup"*) on across pins labeled CLOSE. The display should read "rdyL" when this feature is active. You may want to remove this jumper during installation.

**Usage:** Install your own N.O. push button between ground and terminal #3 of INPUTS/OUTPUTS following the Wiring section of this manual. You must cycle the button to reset the curtain.

### MicroGuard DIN-rail Serial Port

**Description:** Make your connection via the DB-9 pin connector at the Controller Module. You need a DB-9 male cable (straight, not zero modem). The baud rate is 4800. A character is sent every time the status of the curtain changes (see *Table 1 for descriptions*). The unit does not receive commands at this time.

**Application:** To monitor status of the light curtain via RS-232 or RS-485 serial communication port.

**To Activate Feature:** This feature is always active as RS-232. You must specify if you wish RS-485 because it requires a software change as well as an addition of a terminator added to the circuit board.

### Remote Latching Reset

**Description:** When the curtain is blocked, the unit will issue a "STOP" command and remain in this condition until the curtain is clear and the Latching Input is cycled. This feature must be enabled.

**Usage:** Install a N.O. button from I/O Terminal #3 to Power/Relay Terminal #2.

**To Activate:** Install jumper across pins labeled "close".

### Safety Relay Outputs

**Description:** Safety Relays are N.O. (closed when green, open when blocked or power removed). Both K1 and K2 relays each have their own driver circuitry and relay monitoring circuitry, are fully independent of each other, and have their own output terminals.

POWER / RELAY:    K1 (Terminal #4 & 5)  
                          K2 (Terminal #6 & 7)

**WARNING:** You must use both K1 and K2 relays in your "stop" circuit(s). If you have only one "stop" circuit, you must place K1 and K2 relays in series. If you have two "stop" circuits, each relay will have its own "stop" circuit.

NOTE: Safety relays are rated at 8A@ 250vac resistive at room temperature. Inductive loads and high ambient temperatures de-rate that value substantially. It is not recommended that more than 4A@120vac be used through the internal safety relay contacts.

# Standard Features

## DIN-rail Controller Module

**Table 1: DIN-rail Serial Port Diagnostics**

	DIAGNOSTICS DISPLAY	DESCRIPTION
A	RDY Ready	(GREEN light)
B	01 > (numbers on screen show where blockage occurred)	Blockage of curtain field (RED) relays are off.
C	SIZE	Auto Blank object size to large.
D	MOVE Auto	Blank object moved.
E	PENT	Curtain penetrated and locked out (RED)
F		Waiting for reset button to be pushed (scrolling or error code).
G	Reset	button has been pushed.
H	CINN Cincinnati	Interface active (+24v).
I	MUTE	Mute Out in active muting state (outputs bypassed).
J	infrared	Emitter turned off (occurs after you remove blockage to check for external sources).
K	Blockage	of curtain field but waiting for relays to turn off.
L	01 > (numbers on screen show where blockage occurred)	No blockage, relays off, trying to turn on.
M		CPU responding with last order from another CPU.
U	MUTE-OUT SWITCH FAULT	Signal inputs that control Mute function where either in MUTE at power up or both high or low (same state for too long).
V	OPEN EMITTER PYLON	LED in pylon failed or cable to pylon off or bad.
W	SHORT IN EMITTER PYLON	LED in pylon shorted.
X	EMITTER LENGTH FAULT	Physical length of pylon does not match settings in box.
Y	RECEIVER LENGTH FAULT	Physical length of pylon does not match settings in box.
Z	EXT RELAY CONTACT WELD / WIRE CUT	External relay input signal open all the time or at the wrong time.
[	EXT RELAY CONTACT SHORTED	External relay input signal short all the time or at the wrong time.
\	INT RELAY CONTACT STUCK ON	Internal relay closed, but should be open.
]	INT RELAY CONTACT STUCK OFF	Internal relay open but should be closed.
^	NO DATA LINE DETECTED	Slave could not detect data line from Master
_	NO CLOCK LINE DETECTED	Slave could not detect clock line from Master
'	NO G LINE DETECTED	Slave could not detect G line from Master
a	EXT INFRARED SOURCE DETECTED pylon.	Receiver pylon indicating seeing signals when none were transmitted by Emitter
b	RELAY BAD OR MISSING	No RED or GREEN light on box lit up.
c	RAM FAILURE	Ram would not clear.
d	HAD POWER ON RESET	Slave processor has reset itself.
e	HAD CLOCK/WATCHDOG FAILURE	Oscillator or Watchdog failure.
f	DATA TRANSFER CORRUPTED	Checksum error between Master and Slave CPU's.
g	SERIAL TRANSFER INCOMPLETE	Slave and Master could not talk to each other.
h	DATA FROM RECEIVER PYLON NOT CORRECT	Data coming from Receiver pylon not correct.
i	EMITTER ON AT WRONG TIME	LED in Emitter pylon was on but not supposed to be.
j	RECEIVER IS OSCILLATING	A phototransistor in the Receiver pylon was Oscillating.
k	NO MORE CODES	Displayed after all stored fault codes are displayed.
l	INITIATE EEPROM	New EEPROM was tested and initialized for initial use
m		Master wants Slave to store new AB data
n	AB DATA CORRUPTED	Stored Auto Blank pattern has been corrupted.
o	RESET BUTTON HELD DOWN TOO LONG	Reset button has been held down too long or is broken.
p	NO ACK FROM EEPROM	Cannot talk to EEPROM memory.
q	ESTP Emergency	Stop Input



### Analog Output

**Description:** Output can be set up for either 0 to 10V or –10V to 10V and proportional to the area blocked. You must specify the details of the output ( see *Installation Procedures, “Figure 3: Controller Module Wiring Diagram”*).

**Application:** Various

**To Activate Feature:** This feature must be ordered and requires exchanging computer chips ( see *Installation Procedures, “Figure 3: Controller Module Wiring Diagram”*).

### Auto Blank [patent # 5,243,183]

**Description:** With the obstruction in place, turn the key switch from “OFF” to any mode of operation. If the object(s) do not exceed the total allowable size, the unit will energize the safety outputs.

**Application:** Permits you to automatically program the location of an obstruction (i.e., a conveyor , table, work piece, etc.).

**Standard Operation:** If the obstruction is moved or removed, the unit will issue a “MOVE” fault and will re-energize the safety outputs when the obstruction is returned to the original position. Standard operation allows for a total of eight beams to be blocked anywhere in the curtain (they do not have to be next to each other).

**Optional Operation:** If the obstruction is moved or removed, the unit will issue a “MOVE” fault and lockup, requiring you to re-program the obstruction.

**Troubleshooting:** If you get a “MOVE” fault when the obstruction did not move, it is possible that you are just barely covering a beam and either vibration or reflections are causing the beam to become uncovered. The uncovered beam then causes a fault.

**To Activate Feature:** This feature must be ordered and requires exchanging the computer chips ( see *Installation Procedures, “Figure 3: Controller Module Wiring Diagram”*).

**WARNING:** Leave key switch in OFF/RESET position while installing, setting up, and testing the light curtain. Use Auto Blank only after you are able to get a clear signal from the curtain with no obstruction.

### MODE Description

OFF/  
RESET Normal operation (no blanking)

**#1 Mode 2, but guard must be reset if unit is penetrated.** The auto blank obstruction must remain in its exact location permanently Any movement in the Auto Blank obstruction and/ or additional guard penetration will latch the light curtain in a RED condition and must be reset via the keyswitch.

NOTE: If no obstructions were programmed in, the guard will still latch in a RED condition should the guard be penetrated.

**#2 Standard Auto Blank operation.** The Auto Blank obstruction must remain in its exact location permanently. This works like Mode 1 except guard penetrations will not latch in a RED condition.

**#3 Mode 2, plus one beam float.** This mode works like Mode 2 with the addition of a Floating Blank which is set to allow one beam float (see *Optional Features, “Floating Blank”*).

NOTE: If no obstructions were programmed in, the guard will still allow one beam float.

**Programming:** To program, turn the keyswitch into the OFF/RESET position and place the obstruction(s) in the guarded area. Now, turn the keyswitch into the desired mode of operation. The exact size and location of the object(s) are now in memory. **The Penetration Depth Factor D(pf) must be set to account for the one beam float** (see *Optional Features, “Floating Blank, Tables 2a and 2b”*).

### Diagnostics Display

**AB** Auto Blank detected an object (the number indicates the size of the object).

**RDY** No objects programmed in, keyswitch in Mode 1 or 2.

**FB** No objects programmed in, keyswitch in Mode 3

**SIZE** Obstruction size exceeded a total of eight beams.

**PENT** Penetration of the light curtain occurred while keyswitch was in Mode 1.

**MOVE** Auto Blank obstruction moved.

(CONTINUED ON NEXT PAGE)

# Optional Features

## DIN-rail Controller Module

(AUTO BLANK CONTINUED)

**IMPORTANT:** Place Auto Blank keyswitch into OFF/RESET position and remove any obstructions while aligning light curtain. Do not use Auto Blank until light curtain is correctly aligned (see *Installation Procedure*, “Aligning Pylons” and “Aligning Mirrors”).

The keyed selector switch is designated to be supervisory controlled. After installation, the safety key should be removed and controlled only by the safety supervisor or authorized plant personnel.

### Cincinnati Interface

**Description:** A signal from the press control forces the curtain into a blocked “RED” condition. This allows the press control to self check the wiring of the “stop” circuit.

**Application:** Cincinnati press that requires the light curtain to open up the “stop” circuit every press cycle.

**To Activate Feature:** This feature is always active, 24vdc applied to the Cincinnati terminals will force the curtain “RED” at any time.

**Usage:** POWER / RELAY terminal #15: +pos (+24vdc max), terminal #16: -neg (ground). The signal from your press will be either +24vdc or ground when it wants to see the “stop” circuit open up (i.e., sinking or sourcing).

**Sinking:** If your press provides a ground signal to generate a “stop” command, then you must provide +24vdc to terminal #15 and apply the signal line to terminal #16.

**Sourcing:** If your press provides a +24vdc signal to generate a “stop” command, then you must ground terminal #16 and apply the signal line to terminal #15.

### DeviceNet™

Optional external board that plugs into the RS-232 serial port of the DIN-rail Controller Module. External board comes with its own direction.

### Floating Blank

**Description:** A key switch by default allows for 0, 1, 2, 3 beams to be blocked anywhere in the curtain as long as all the blocked beams are next to each other. The customer may request different blanking sizes for different applications. The Minimum Object Sensitivity and the Depth Penetration Factor (DPF) change when the key switch position is changed. The DPF is used to compute the safety distance.

**Application:** On a press brake, the Floating Blank permits the work piece to be placed in the guarded area and can be moved around as long as it does not exceed the object sensitivity selected.

**Table 2a: .5” Beam Spacing Pylons**

Display	Minimum Object Sensitivity, S	D(pf) Depth Penetration Factor	Max. Floating object size less than
	Inches/Millimeters	Inches/Millimeters	Inches/Millimeters
RDY (float off)	0.55" / 14mm	0.935" / 23.8mm	0.00" / 0.0mm
FB1 (1 beam float)	1.18" / 30mm	3.077" / 78.2mm	0.45" / 11.4mm
FB2 (2 beam float)	1.75" / 45mm	5.015" / 129.2mm	0.95" / 24.1mm
FB3 (3 beam float)	2.36" / 60mm	7.089" / 180.2mm	1.45" / 36.8mm
FB4 (4 beam float)	2.95" / 75mm	9.095" / 231.2mm	1.95" / 49.5mm
FB5 (5 beam float)	3.54" / 90mm	11.101" / 282.2mm	2.45" / 62.2mm
FB6 (6 beam float)	4.13" / 105mm	13.107" / 333.2mm	2.95" / 74.9mm

**Table 2b: 1” Beam Spacing Pylons**

Display	Minimum Object Sensitivity, S	D(pf) Depth Penetration Factor	Max. Floating object size less than
	Inches/Millimeters	Inches/Millimeters	Inches/Millimeters
Rdy (float off)	1.18" / 30mm	3.077" / 78.2mm	0.00" / 0.0mm
FB1 (1 beam float)	2.36" / 60mm	7.089" / 180.2mm	0.95" / 24.1mm
FB2 (2 beam float)	3.54" / 90mm	11.101" / 282.2mm	1.95" / 49.5mm
FB3 (3 beam float)	4.72" / 120mm	15.113" / 384.2mm	2.95" / 74.9mm

**To Activate Feature:** This feature must be ordered and requires exchanging the computer chips.

**WARNING:** The safety distance must take into account the maximum blanking size which alters the Depth Penetration Factor.

**WARNING:** Make sure that the diagnostics display does not show blockage when there is none present.

**Minimum Object Sensitivity** indicates the minimum size required to cause the light curtain to detect an object even if it is moving (floating). If the obstruction is slightly smaller (less than 0.25”) than the stated number, the light curtain may blink RED/GREEN when the object is moving in the field of view. If the obstruction is smaller than the stated number by at least 0.25”, then the light curtain will stay GREEN as long as there are no additional obstructions.

**Depth Penetration Factor** is the number used to compute the distance the light curtain should be placed from the point of operation (see *Installation Procedure*, “ANSI Standard B11.19-2003”).

### Diagnostics Display

- RDY** Keyswitch is in the lowest position (Floating Blank is off).
- FB** Indicates Floating Blank active and the number of blocked beams.
- OBST** A second object found in the curtain (only one obstruction is allowed to float).

(FLOATING BLANK CONTINUED)

**IMPORTANT:** Place Floating Blank keyswitch into 0.5" position and remove any obstructions while aligning light curtain. Do not use Floating Blank until light curtain is correctly aligned (see *Installation Procedure, "Aligning Pylons" and "Aligning Mirrors"*).

The keyed selector switch is designated to be supervisory controlled. After installation, the safety key should be removed and controlled only by the safety supervisor or authorized plant personnel.

### Guarding Mute-Out

**Description:** Two inputs (LS4 and LS5) are required to use the Mute-Out feature. These inputs can come from limit switches or PLC outputs that act as limits. The signal to start Mute-Out should occur no sooner than ¼" from ram closure and end before the hazardous portion of the machine cycle begins (see *Installation Procedures, "Figure 3: DIN-rail Controller Module Wiring Diagram"*).

**Application:** Allows any object to pass through the light curtain without opening the stop circuit and interrupting the machine cycle (i.e., the curtain stays GREEN).

**Usage:** The Mute-Out portion of the cycle occurs between the pinch point and top stop (about 180° to 300°) or any non-hazardous portion of your machine cycle.

You must power up the MicroGuard out of Mute-Out condition, any other condition will cause an error to occur and you will have to power down the guard to reset it. When in Mute-Out, the MicroGuard will display "MUTE." If LS4 or LS5 limit switches are ever caught out of sequence, the guard will fault and issue an error message of "MUTE-OUT SWITCH FAULT" or "SLV MUTE-OUT SWITCH FAULT."

**To Activate Feature:** This feature must be ordered and requires exchanging the computer chips (see *Installation Procedures, "Controller Module Setup"*).

**Table 3: Truth Table**

LS4	LS5	CONDITION	DISPLAY
OPEN	CLOSED	GUARDED	RdyM
CLOSED	OPEN	MUTE-OUT	MUTE
OPEN	OPEN	FAULT	Mute out switch fault
CLOSED	CLOSED	FAULT	Mute out switch fault

LS4 = I/O Terminal #4 & LS5 = I/O Terminal #5

If both signals remain in the same state (i.e., both closed or both open) for more than 100mSec, a fault will be issued.

**NOTE:** To by-pass this feature, jumper LS5 (I/O terminal 4) to ground (Power/Relay terminal #2).

**WARNING:** Do not use one switch or one relay to generate the two inputs needed—it is unsafe!

**WARNING:** Make sure that Mute-Out occurs only on the non-hazardous portion of the machine cycle.

### Remote Diagnostics Display

**Application:** To view the display from the front panel without having to open the door.

**To Activate Feature:** You must purchase the remote display and cable.

**Usage:** The connector for the remote display is located under the top cover of the Controller Module to the left of the built-in display. Pull the boards out of the housing and cut away the top cover to expose the connector.

### Remote Indicator Lights

**Application:** To view the status indicator lights from the front panel without having to open the door.

**To Activate Feature:** Purchase sealed LED indicator lights from the manufacturer or use your own.

**Usage:** (see *Installation Procedures, "Wiring", and "Figure 3: DIN-rail Controller Module Wiring Diagram"*).

### Remote Key Switch

**Application:** To control the blanking functions.

**To Activate Feature:** Purchase the key switch and label for the blanking style desired.

**Usage:** Refer to Floating Blank or Auto-Blank (see *Installation Procedures, "Figure 3: DIN-rail Controller Module Wiring Diagram"*).

# Installation Procedures

## DIN-rail Controller Module

**WARNING:** The entire machine safety system must be tested at the start of every shift. Machine testing should include: (1) proper machine operation and stopping capability; and (2) verification of proper installation and settings of all point of operation guards and devices before the operation is released for production.

**WARNING:** The MicroGuard DIN-rail should be mounted in a manner so that only authorized personnel can change the mounting or location and that the safety distance is recalculated each time its position is changed.

**WARNING:** Additional mechanical guards may be required to prevent the operator from standing between, reaching over, under, or around the light curtain to the hazardous point of operation.

NOTE: Other infrared sources (i.e., other light curtains, single beam eye's, etc.) can prevent this light curtain from properly aligning and giving a GREEN indication. Make sure other sources are not in view of the Receiver pylon.

NOTE: The MicroGuard DIN-rail is a low voltage device and operates with low voltage and low current signals. Make sure to keep all parts of this system as far away from high voltage devices as possible.

- 1) Before installation, test the light curtain by installing the cables between the pylons and applying power to the Controller Module. Point the pylons toward each other and verify a "RDY" or GREEN indicator. If you cannot get a GREEN indicator, see Appendix A: Diagnostics and Troubleshooting.
- 2) Determine the Safety Distance of the light curtain from the hazardous point of operation (see *Installation Procedures, "ANSI Standard B11.19-2003"*). You must know the total stop time of your machine.
- 3) Determine if any part of the Microguard is to be directly subjected to either excessive shock and/or vibration. If so, mount the subjected parts to your equipment using shock-mount devices (such as Part# 21-019). Shock and/or Vibration damage is not covered under warranty.
- 4) Mount both pylons with the connector side in the same direction (whether up or down) across the hazardous area at a distance from the hazardous point of operation, equal to or greater than the calculated safety distance.

NOTE: Shock mount the pylons if they are to be directly mounted onto a high vibration machine. Do not lock down the pylons or mirrors until proper alignment is obtained.

- 5) Mount the Controller Module inside your control panel. The Controller Module should be placed as far away from high voltage devices as possible while remaining inside your control panel.
- 6) Use mirrors to turn a corner 90° or more but no less. If you are using pedestals, do not permanently mount them until you have finished the installation procedure. When you have a GREEN indicator, bolt the stands to the floor. Make sure the bottom edge of the mirror(s) are below the bottom beam of the curtain and the top edge of the mirror(s) are above the top beam of the curtain.
- 7) Dress the pylon cables either inside their own conduit, or tie-wrapped away from high voltage devices. Even though the cables are shielded, they carry low voltage, low current signals.
- 8) Either roll up excess cable inside the Controller Module or cut the cable to proper length and re-strip the wire ends (see *Wiring section for further details*).
- 9) Wire power to the Controller Module and align pylons for a GREEN indicator with no blockage present. Lock down pylons, mirror(s), and pedestals at this point (see *Installation Procedures, "Wiring," "Aligning Pylons," and "Aligning Mirrors"*).
- 10) Connect the Controller Module Safety Relay Outputs into the hazardous machine's STOP circuit. Connect all other features that your installation requires (i.e., mute-out, external relay checking, etc.) (see *Installation Procedures, "Wiring"*).

### Resetting Faults

Press the FN1 button on top of the Controller Module to reset faults.

### System Check

- 11) Check the curtain's field of view with a round test piece (i.e., dowel rod) that has a diameter equal to the minimum object sensitivity of the curtain (see *Specifications section for numbers*). When penetration into the curtain's field of view is performed, the guarded machine should shut down. Move the test piece up and down the curtain's field of view to make sure there are no spots where the curtain indicates a GREEN condition.



**WARNING:** If you get a GREEN indication while the test piece is in the curtain's field of view, this may be due to any of the following reasons: (1) an incorrectly sized test piece; (2) the Floating Blank option is enabled and set larger than what you believe it to be; or (3) there is a reflection from adjacent reflective material. If #3 appears to be the case, you must move the reflective material further away from the curtain or the curtain away from the material.

- 12) Install additional mechanical guards to prevent anyone from getting to the hazardous point of operation by reaching around, over, or under the curtain. Also, to prevent anyone from getting in between the curtain and the hazardous point of operation, install L-shaped light curtains or safety mats.

### Aligning Pylons

Mechanically line up the pylons so they are looking straight at each other. Twist the pylons to find the center of their sweet spot (the point at which you get a solid GREEN indicator). If you are trying to run the pylons close to the maximum operating distance, you may have to tip one end of the Emitter pylons to get a GREEN indication.

The diagnostics display will show the location of the first blocked beam. If you push the "FN1" button on the Controller Module, the display will show you the location of the next blocked beam. The last digit indicates how many beams are blocked (see Appendix A: Diagnostics & Troubleshooting for more details).

### Aligning Mirrors (refer to Figure 1)

Every mirror you add reduces the maximum operating distance by -10% and also increases the difficulty of alignment. Because of the width of the mirrors and the shoulders of the aluminum extrusion that protect the mirror, you cannot turn a corner less than 90°.

The vertical height of the mirror with respect to the vertical height of the pylons should be such that the mirror matches the beam area of the pylons. You should have some mirror showing above the top beam and below the bottom beam.

All mirrors and pylons should be plumb. You should be able to stand in front of one of the pylons, look straight ahead, and see the other pylon through the center(s) of the mirror(s). Depending on what the diagnostics display reads, you may have to tip one end of the mirror to get the remaining blocked beams to come in.

**Figure 1: Mirror Alignment**

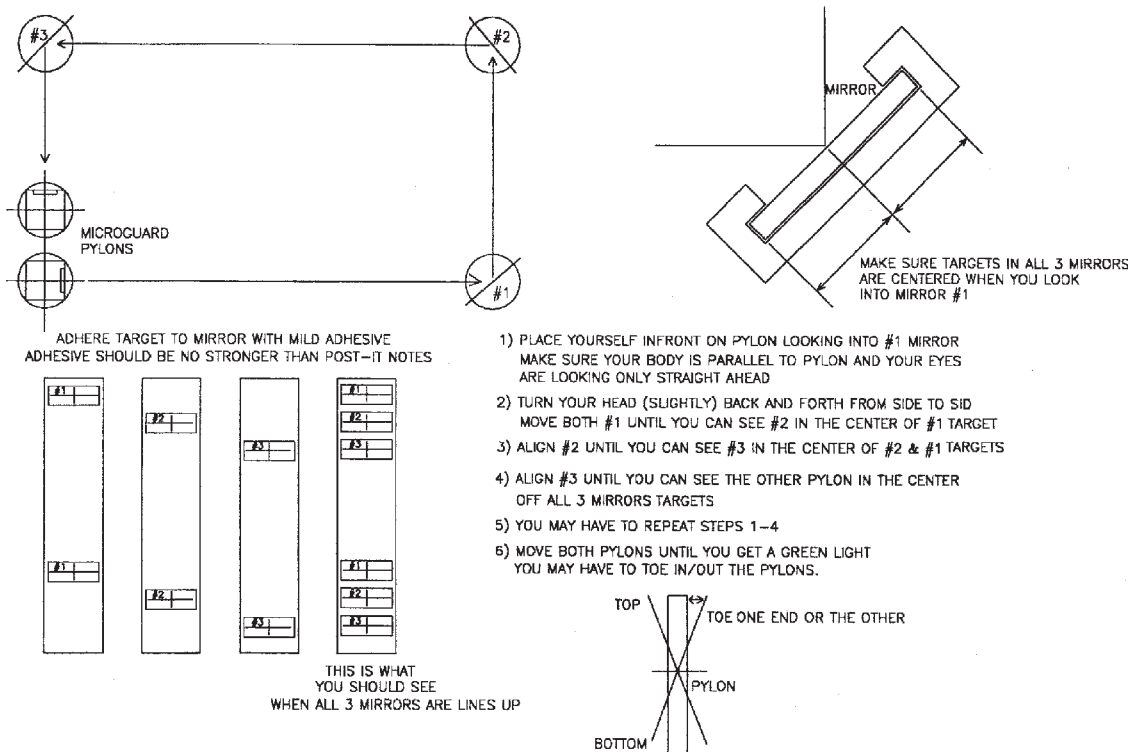

# Installation Procedures

## DIN-rail Controller Module

### Operations

NOTE: Examine the MicroGuard on a daily basis to make sure that no one has moved the light curtain pylons closer to the pinch point or removed any mechanical guards from around the curtain.

NOTE: If it is possible for someone to go through the light curtain and remain in a dangerous area without having to block the light curtain, you must order the Resettable Latchout option which keeps the curtain RED even after you are no longer blocking the curtain. The Latchout reset button is mounted away from the dangerous area and must be cycled to reset the curtain.

- 1) Power up the light curtain. If a fault occurred the last time the unit was powered and was never RESET, it will appear as a "SLAVE FOUND" error message and you will have to push the RESET button to clear the fault message and start the curtain.
- 2) When GREEN the curtain display will say "RDY" or "rdy" depending on any options that were set (see *Appendix A: Diagnostics & Troubleshooting* for more details).
- 3) When RED due to blockage, the display will indicate the location of the first obstruction(s) and the total size of the obstruction(s) (see *Appendix A: Diagnostics & Troubleshooting* for more details). If you have Floating Blank, then this is indicating that your object is too large for the floating size you have selected. If you increase the Floating Blank size, you must recalculate the safety distance formula since the object sensitivity will be larger. If you have the Resettable Latchout option, the display will show "PENT" to indicate penetration. You must cycle the Latchout RESET button to clear the curtain (see *Standard Features, "Resettable Latching Relays"*).
- 4) When RED due to a fault, the display will scroll the error message that caused the fault and the board and beam number (if it can be pinpointed). You must first correct the fault, and then push the RESET button to clear the fault from memory, even powering down the unit will not clear the fault from memory (see *Appendix A: Diagnostics & Troubleshooting* for more details).
- 5) If you have the MUTE-OUT option, the display will show "MUTE" during the up stroke. If you have the Cincinnati Interface hooked up, the display will show "CINN" during the up stroke (see *Optional Features, "Guarding Mute-Out"*).
- 6) **Auto Blank.** The display will show "AB" to indicate that an object is programmed in and its size (in beams) is shown as the next digit. If you keep getting a "MOVE" message and your object is not moving, try repositioning the object slightly (+- 1/4") and reprogram it back into memory. If you get a "SIZE" message, you must either get new software to allow a larger object or reduce your object size.
- 7) **Floating Blank.** The display will show "FB" to indicate the allowed blanking size in beams. Once an object penetrates the curtain, any second object will cause the curtain to display "OBST" to indicate that a second obstruction is in the curtain. This is done in case you select a Floating Blank size much larger than the actual object size.



# Installation Procedures

## DIN-rail Controller Module

### ANSI Standard B11.19-2003

Formula for calculating safety distance of light curtains from hazardous point of operation.

The effective sensing field of the device shall be located at a distance from the nearest recognized hazards such that the operator or others cannot reach the hazard with a hand or other body part before cessation of motion during the hazardous portion of the machine cycle.

The point at which a device responds to an intrusion may vary. The devices should be located or adjusted such that the device always responds to the intrusion at or prior to the safety distance. Care should be exercised when installing the device to ensure that it does not detect false signals from other devices in the area.

Usually the electro-optical presence-sensing device is used in a manner that provides a protected zone in front of the primary work area with auxiliary devices or guards used to protect secondary access areas. In some cases, however, mirrors may be used in conjunction with the device to provide 2-, 3-, or 4-sided protection.

The machine stop time should be measured with the machine running at its fastest speed with its heaviest die or tooling and the stop time being measured at the 90° position in the downstroke.

The following formula should be used when calculating the safety distance:

$$D_s = K \times (T_s + T_c + T_r + T_{bm}) + D(pf)$$

- $D_s$  = Minimum safety distance between the device and the nearest point of operation hazard (in inches).
- $K$  = Hand speed constant. This value has been determined by various studies and, although these studies indicate speeds of 63 in/sec to over 100 in/sec, they are not conclusive determinations. The employer should determine this value by considering all factors, including physical ability of the operator.
- $T_s$  = Stop time of the machine tool measured by a stop time measurement device.
- $T_c$  = Response time of the control system (usually is taken care of by the measurement device).
- $T_r$  = Response time of the presence-sending device and it's interface, if any, as stated by the manufacturer or measured by the employer.
- $T_{bm}$  = Additional time allowed for the brake monitor to compensate for variations in normal stopping time.
- $D(pf)$  = Depth Penetration Factor. Added distance as indicated by Figure 2. The minimum object sensitivity is stated by the manufacturer. If a Floating Blank is used, use the Dpf numbers

**Figure 2: Minimum Object Sensitivity and D(pf)**

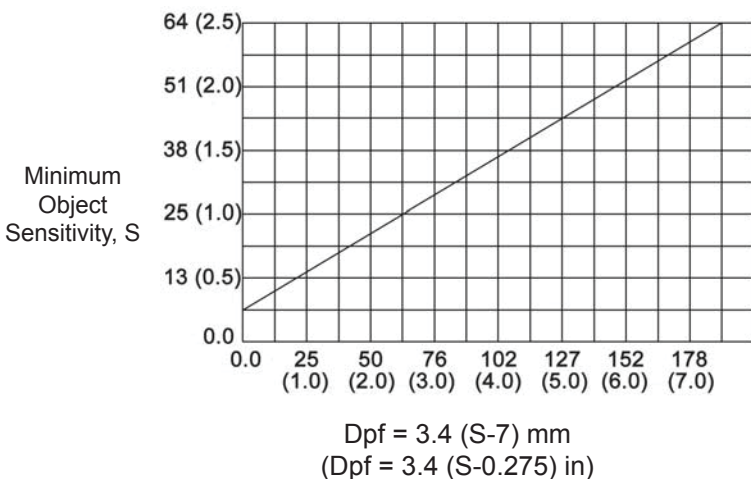

### Penetration factor, Dpf, for presence-sensing devices used in a vertical application with object sensitivity less than 64 mm (2.5 inches)

Dpf, the distance added to the safety distance due to the penetration factor compensates for varying object sensitivities of electro-optical presence-sensing devices.

When blanking features are used and when the blanked area is not completely filled by the workpiece or part, or by mechanical guarding, the minimum object sensitivity can be calculated as:

$$\text{Object sensitivity} = \text{size of the blanked area plus minimum object sensitivity without blanking.}$$

Once this value is found, then determine Dpf.

If the entire blanked area is filled with mechanical guarding or other fixed material or guards, use the device's object sensitivity to determine Dpf.

# Installation Procedures

## DIN-rail Controller Module

### Safeguarding with Mechanical Guards

When a light system is used to protect the operator or passerby from penetration, it must be mounted and properly sized (grid length) so it is impossible to reach under, around, or over into the hazardous point of operation zone. Infrared light systems normally guard the front or feed area of a machine. The sides or the areas where the light screen does not guard must be guarded by some other means.

If the position of the safety light curtain will allow the operator or others to place themselves between the sensing field and the hazardous area, auxiliary guards or devices such as safety mats, barrier guards, or devices should be used in conjunction with the safety light curtain to prevent the operator or others from exposure to the hazardous area. If mechanical guards such as polyurethane, expanded or perforated metal, hairpins, etc. are used to guard these areas, the opening must comply with the OSHA safety distance in relationship to the openings.

After installation of point of operation guards and before a job is released for operation, a check should be made to verify that the guard will prevent the operators hands from reaching into the point of operation or any hazard zone.

Table 4 outlines the distances that guards should be positioned from the nearest point-of-operation hazards.

The various openings are such that for average-sized hands, an operator's fingers will not reach the point of operation.

After installation of point-of-operation guards and before a job is released for operation, a check should be made to verify that the guard will prevent the operator's hands or other body parts from reaching the point of operation.

**Table 4: Mechanical Guards**

Distance of opening from point of operation hazard (inches)			Maximum width of opening (inches)
1/2	to	1-1/2	1/4
1-1/2	to	2-1/2	3/8
2-1/2	to	3-1/2	1/2
3-1/2	to	5-1/2	5/8
5-1/2	to	6-1/2	3/4
6-1/2	to	7-1/2	7/8
7-1/2	to	12-1/2	1-1/4
12-1/2	to	15-1/2	1-1/2
15-1/2	to	17-1/2	1-7/8
17-1/2	to	31-1/2	2-1/8

### Light Curtain Test Procedure

Use a dowel rod (or similar object) with a diameter equal to the M.O.S. (Minimum Object Sensitivity) of the guard you are testing. Move the rod through the field of the curtain (i.e. top to bottom for vertically mounted curtains). Repeat this test close to the Emitter pylon, close to the Receiver pylon, in the middle between the pylons, and most importantly in front of the operator position.

Make sure the curtain indicates a "Blocked" condition (RED light) when the rod is in the field of the curtain.

Check and make sure the machine cannot move when the curtain shows "Blocked". If the machine can operate while the curtain shows a "Blocked" condition, then re-examine your wiring.

NOTE: Always use both safety relays in your STOP circuit(s).

If the curtain does not show "Blocked" when the rod is in the field: Check to make sure the rod is truly in the curtain's field, and re-check the curtain's Minimum Object Sensitivity (including AutoBlank and Floating blank options that change the M.O.S.).

Infrared light from the curtain may be reflecting around the rod due to reflective material too close to the curtain's field. In this case, you will have to move the curtain pylons back away from the reflective material and repeat the test over again. The curtain's power level can also be reduced by the factory.

### Wiring

Table 5 is a sample of how to wire the Controller Module. Certain features are not needed for many installations. Read the sections in this manual describing each feature to decide which feature(s) you may need.

**WARNING:** Both K1 and K2 Safety Output Relays must be used to issue a “ST OP” signal to your hazardous machinery—either with two separate stop circuits or both relays wired in series.

**Tables 5a-f: Controller Module Wiring**

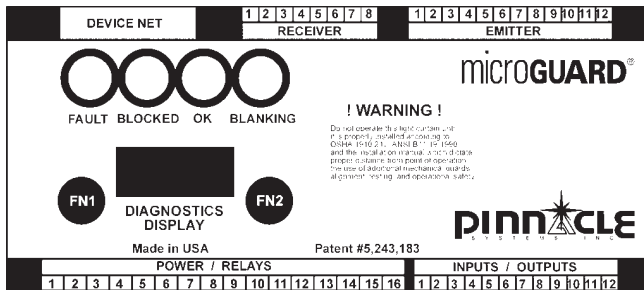

#### RS-232 Serial Port (optional) a

Terminal	Connector
1	+15VDC out
2	Transmit
3	Receive
5	Ground
6	+15VDC Out
8	+15VDC out
9	Ground

#### RS-485 Serial Port (optional) b

Terminal	Connector
1	+15VDC out
2	tx/rx
3	tx/rx
5	Ground
6	+15VDC Out
8	+15VDC out
9	Ground

#### Receiver Wire Colors c

Terminal	Connector
1	Green & Red
2	Black & Brown
3	Purple
4	White
5	Blue
6	Yellow
7	Orange
8	Shield (bare)

#### Emitter Wire Colors d

Terminal	Connector
1	Shield (bare)
2	Yellow
3	Orange & Blue
4	Purple
5	Black/White
6	Brown
7	Green
8	Red
9	Red/white
10	Gray
11	Black
12	White

#### Power/Relays e

Terminal	Connector
1	+24VDC Input
2	-24 VDC input
3	Earth Ground
4	Safety Relay K1 N.O. (Red = open)
5	Safety Relay K1 N.O.
6	Safety Relay K2 N.O.
7	Safety Relay K2 N.O.
8	Auxiliary Relay K3 N.O.
9	Auxiliary Relay K3 Common
10	Auxiliary Relay K3 N.O.
11	Fault Relay K4 N.O. (open = fault)
12	Fault Relay K4 N.O.
13	External Relay Input + side
14	External Relay Input - side
15	ESTOP +24VDC (optional CINN +)
16	ESTOP Button 1 (optional CINN-)

#### Inputs / Outputs f

Terminal	Connector
1	Analog Output + side
2	Analog Output - side
3	Latching Relay Input (ground to reset)
4	Mute-Out Input (LS4 input)
5	Mute-Out (LS5 input)
6	Remote Key Switch Key #1 (black wire)
7	Remote Key Switch Key #2 (red wire)
8	ESTOP Button 2
9	+24VDC input to power optically coupled inputs
10	Remote Blanking Indicator Output (ground when on)
11	Remote Blocked Indicator Output (ground when on)
12	Remote OK Indicator Output (ground when on)

# Installation Procedures

## DIN-rail Controller Module

Figure 3 is a diagram representing *only* one wiring method.

- If hazardous machine requires two separate “stop” circuits, you must remove the jumper between terminal 5 & 6 of the POWER / RELAYS strip and use terminal 4 & 5 for “stop” circuit #1 and terminal 6 & 7 for “stop” circuit #2.
- If your hookup requires a high inductive current through the “stop” circuit, you must use the External Relay Checking feature (see *Standard Features*, “*External Relay Check*”).
- If you require manual resetting after intrusion into the curtain, enable the Latching Relay feature by installing the “close” jumper inside the Controller Module and follow the wiring diagram on the following page (see *Standard Features*, “*Resettable Latching Relays*”).
- If you require Mute-Out on your press’ s up-stroke, purchase the Mute-Out option, swap out the computer chips U15 and U21 with Mute-Out enabled ones, and follow the wiring diagram on the following page (see *Optional Features*, “*Guarding Mute-Out*”).
- If you want remote indicators/diagnostics display, purchase the Remote Indicator option and follow the MicroGuard DIN-rail wiring diagram on the following page (see *Appendix A: Diagnostics & Troubleshooting*).
- If you require Floating Blank or Auto Blank, purchase the option, swap out the computer chips U15 and U21 with the Blanking enabled, and follow the wiring diagram on the following page (see *Optional Features*, “*Floating Blank*” or “*Auto Blank*”).

NOTE: The Blanking Key Switch can also be installed in the Controller Module.

**Figure 3: DIN-rail Controller Module Wiring Diagram**  
 (Combination of any feature below is allowable)

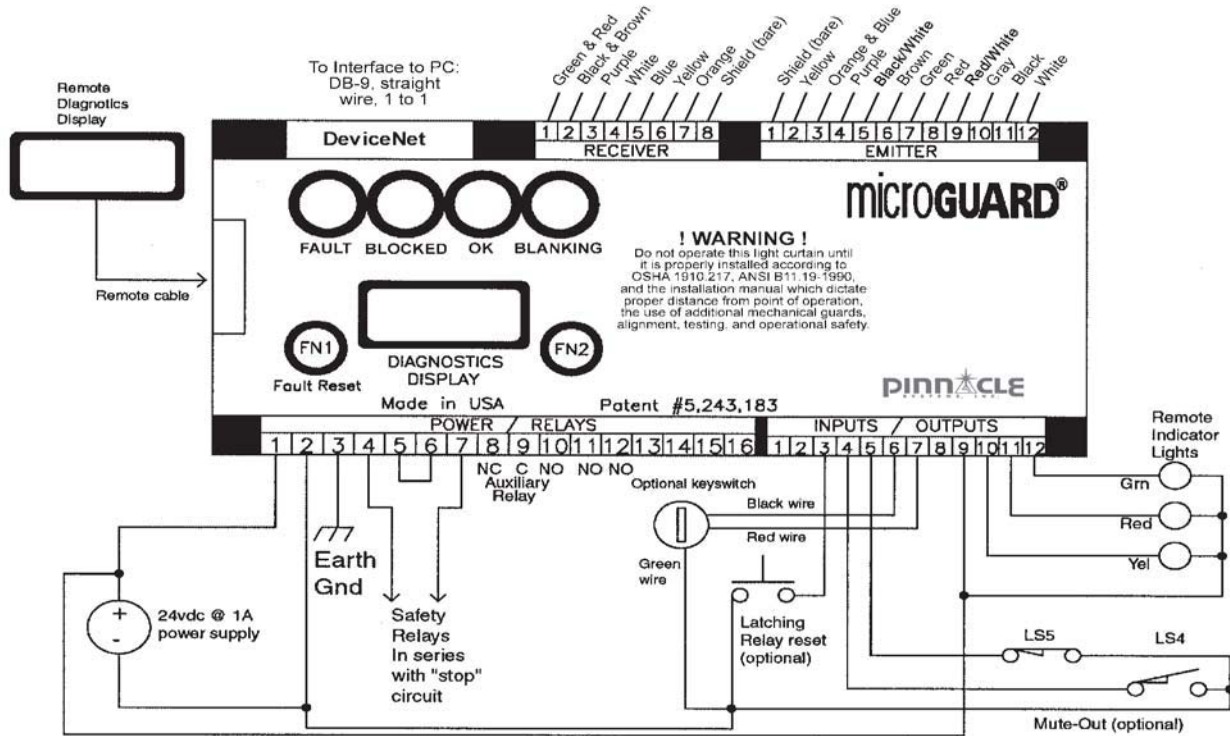

**External Relay Checking (Usage is optional)**

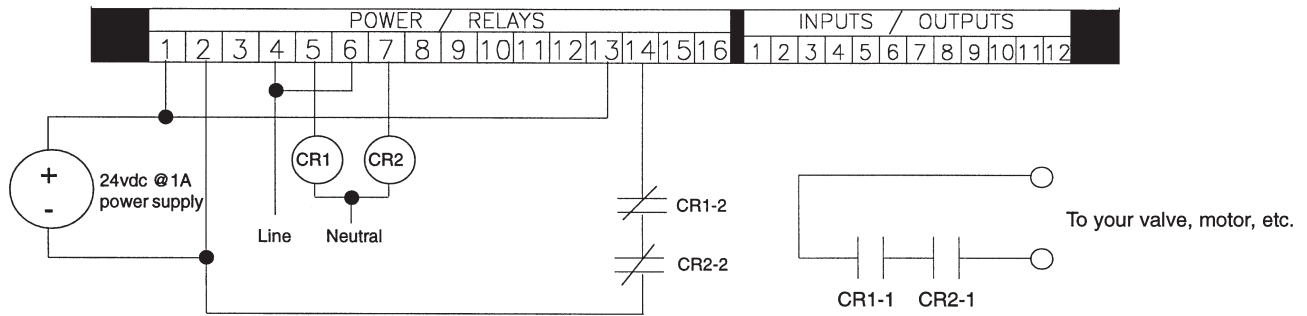

**Emergency Stop Input (Usage is optional)**

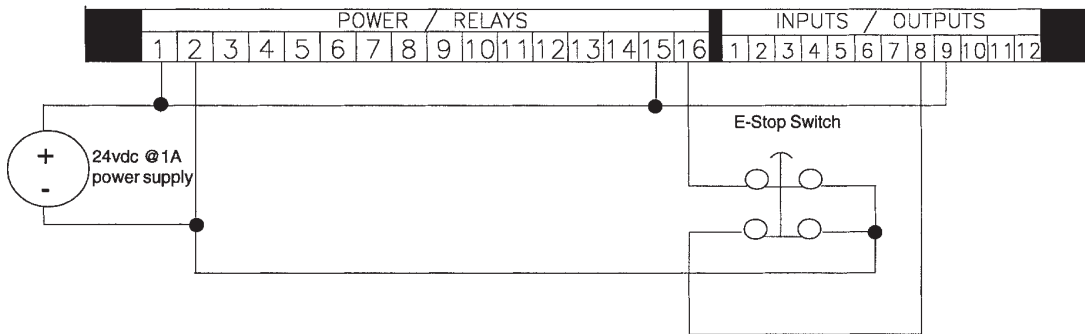

Note: If the Emergency Stop Input mushroom button is not used, the circuit still must be completed.

# Installation Procedures

## DIN-rail Controller Module

### Controller Module Setup

Internal jumpers inside the Controller Module allow for selection of pylon length (height of tower itself). Table 5 demonstrates how to set the internal jumpers if you wish to use the Controller Module with a set of pylons that are a different length.

**EXT** Activates External Relay Checking function (see *Standard Features, "External Relay Check"*).

**FLASH** Increases immunity to weld flash by slowing down the curtain (doubles response time).

**CLOSE** Activates Latching Relay Reset feature (see *Standard Features, "Resettable Latching Relays"*).

**AB/FLT** Selects either Auto Blank or Floating Blank (jumper = Auto Blank).

**Table 6: Internal Jumper Settings with Different Pylon Lengths**

1=jumper

	4"	8"	12"	16"	20"	24"	28"	32"	36"	40"	44"	48"	52"	56"	60"	64"							
LO 1			1		1				1				1			1				1		1	
L1 1		1				1	1						1	1						1	1		
L2 1	1	1	1	1									1	1	1	1							
L3 1	1	1	1	1	1	1	1	1	1	1	1												

Note: 1" pylons in lengths from 68" to 120" cannot be jumper selected. The unit must be programmed for the required length.

**Figure 4: Internal Circuit Board View**

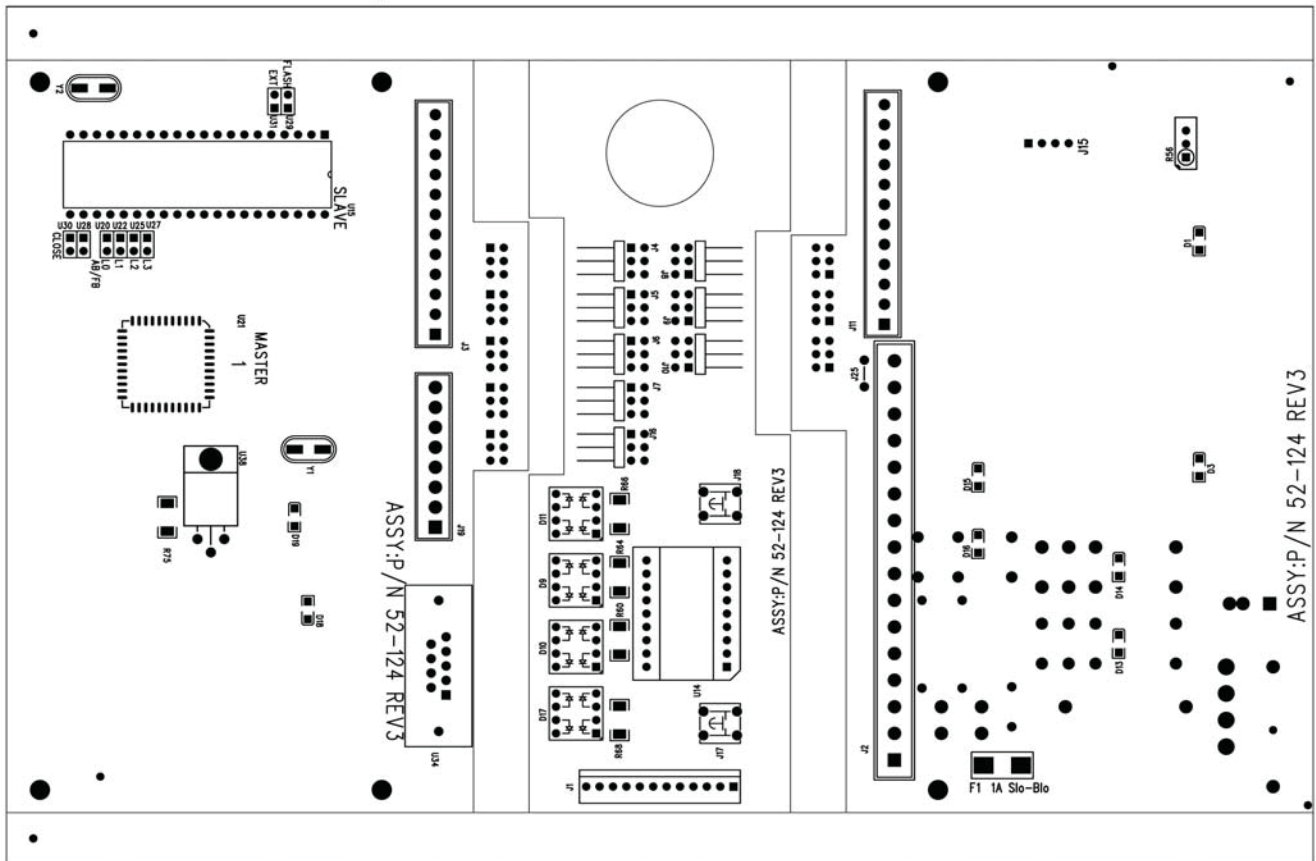



Pylon Dimensions

Figure 5a: Swivel Bracket Dimensions

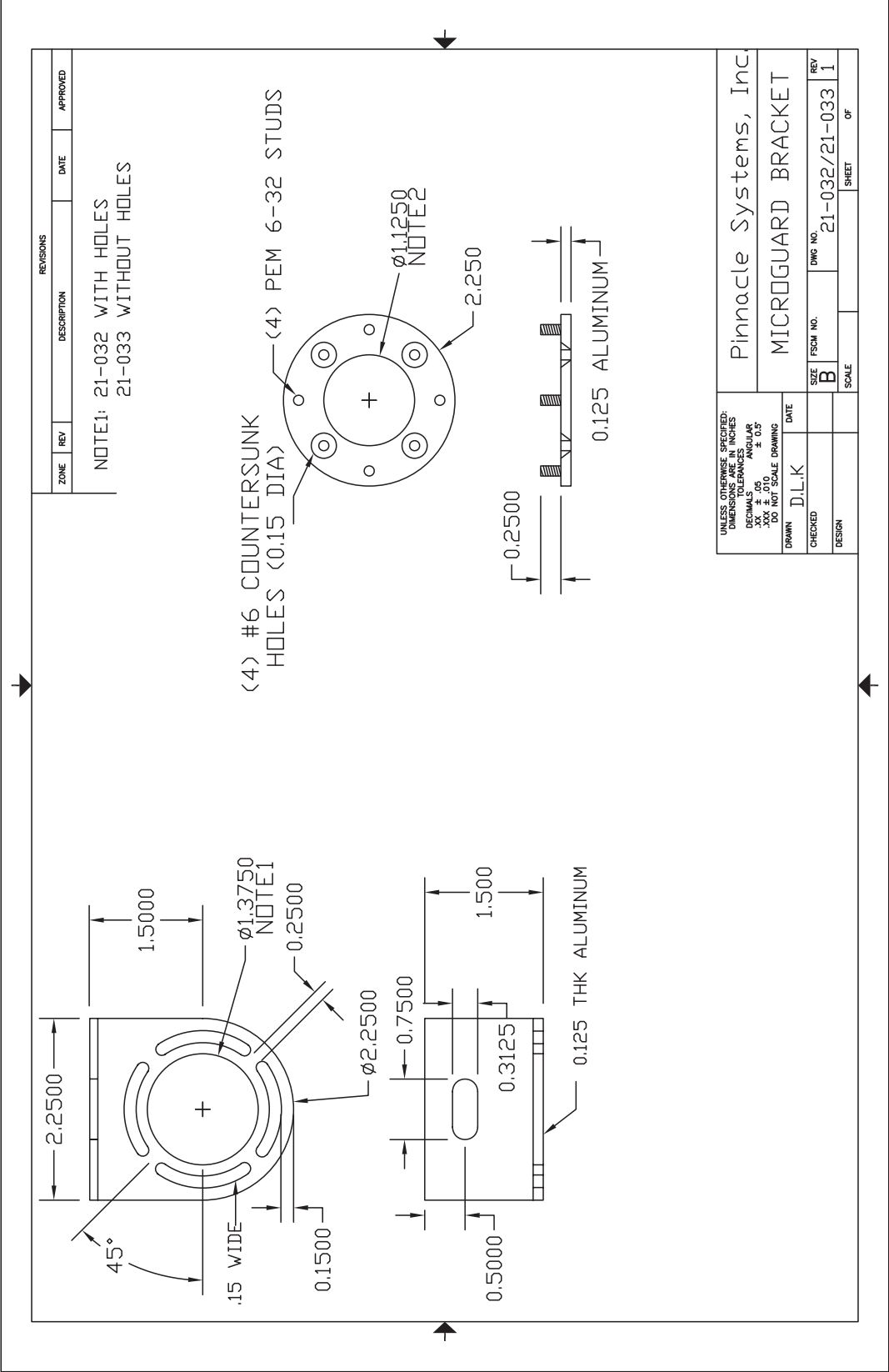

# Dimensions

## DIN-rail Controller Module

### Pylon Dimensions

Figure 5b: Swivel Bracket Dimensions, pylon dimensions (by model), and additional cable information

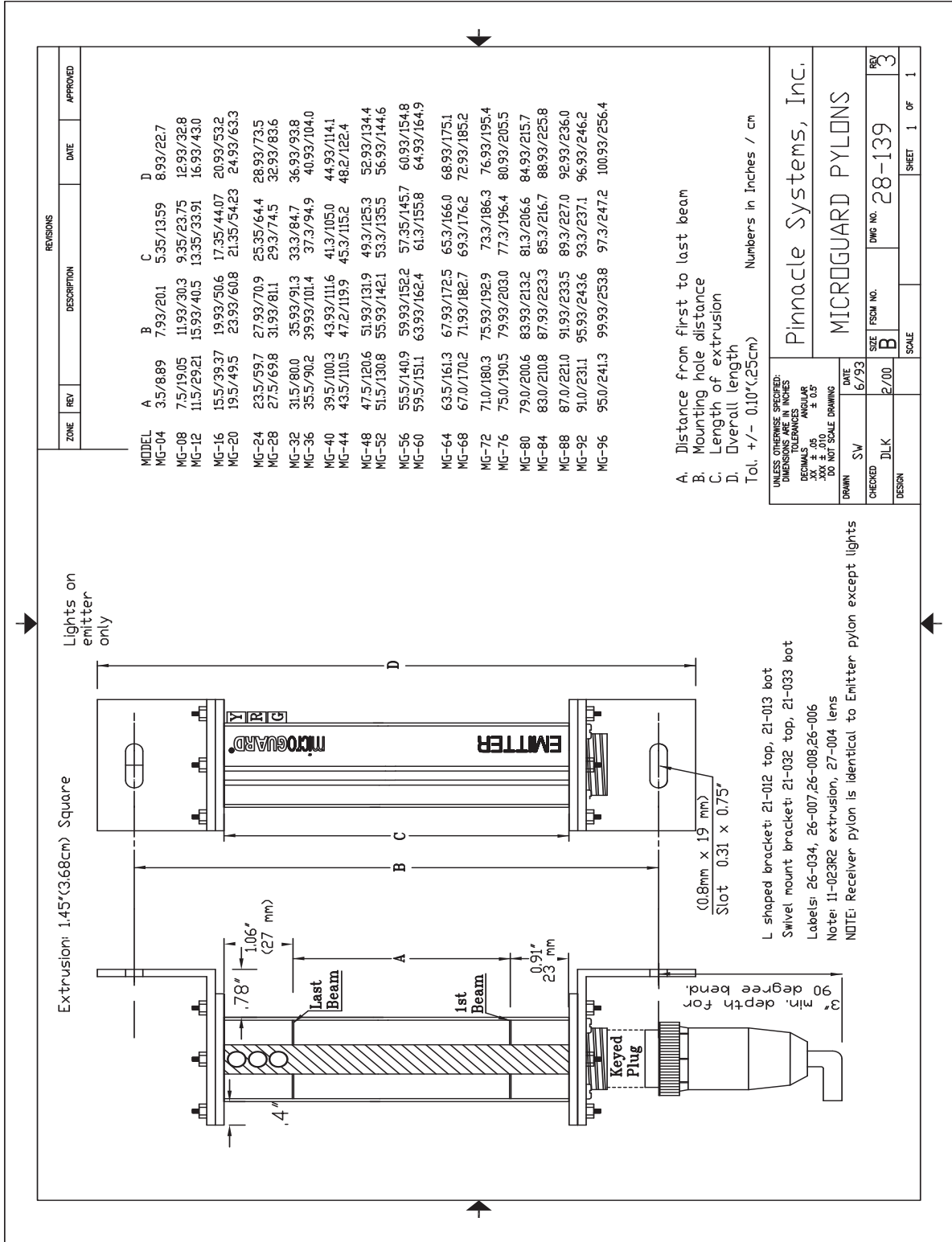
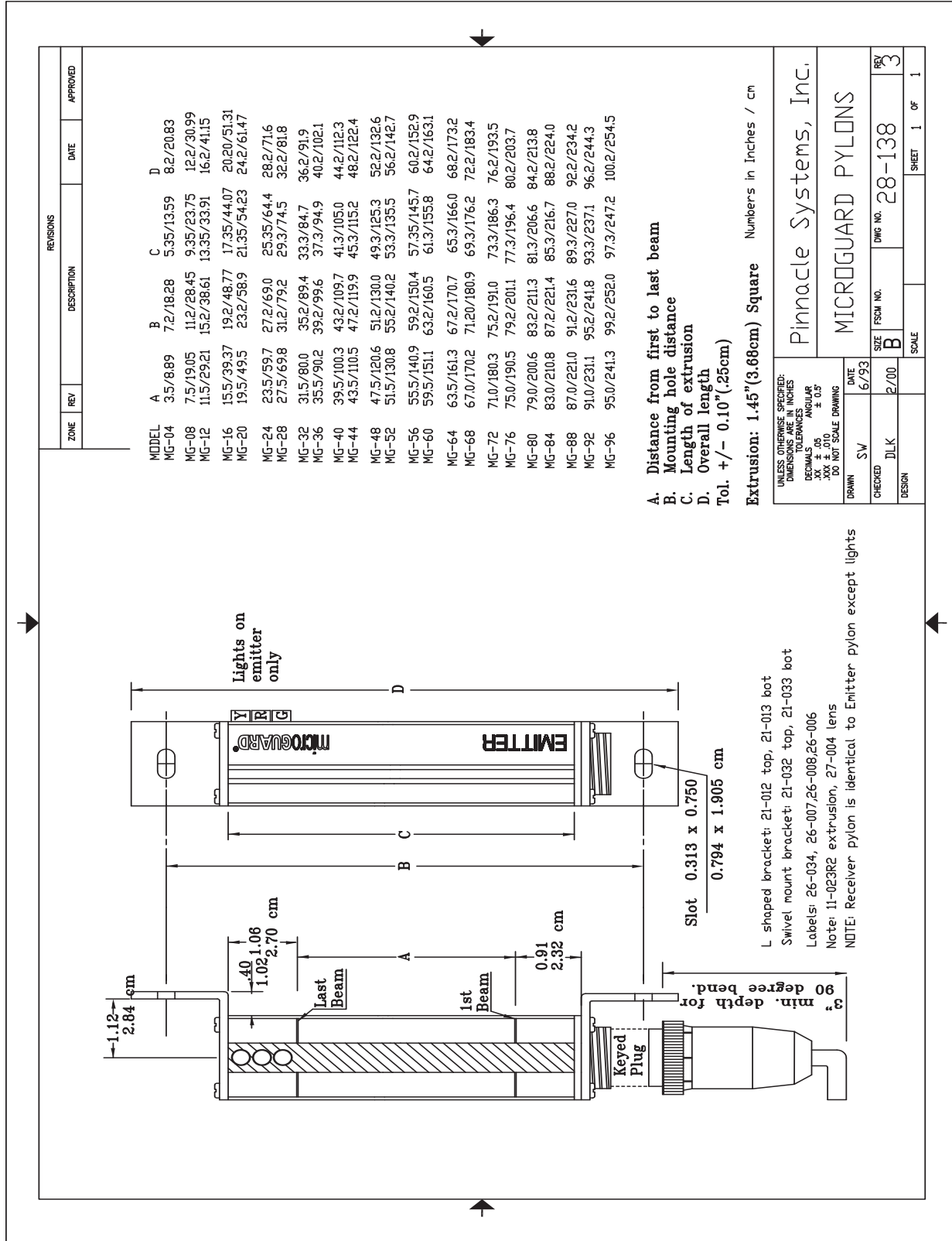

Figure 6: Fixed Bracket Dimensions, pylon dimensions (by model), and additional cable information



# Dimensions

## DIN-rail Controller Module

### Controller Module

The Controller Module can be either DIN-rail mounted or screwed down. Be sure to allow space for wiring to top of box (both sides).

**Enclosure:** Gray polycarbonate with clear cover .  
Provides IP40, UL94V-1

**Enclosure Dimensions:** 5.87" (149 mm) length x 4.33" (110 mm) depth x 2.95" (75 mm) height.

**Enclosure Mounting:** 35mm DIN-rail mountable or Mounting screws on corners of enclosure requiring two combo-head screws (3.5 x 0.6mm x 14 mm or #6 x .5).

Figure 7: DIN-rail Controller Module Dimensions

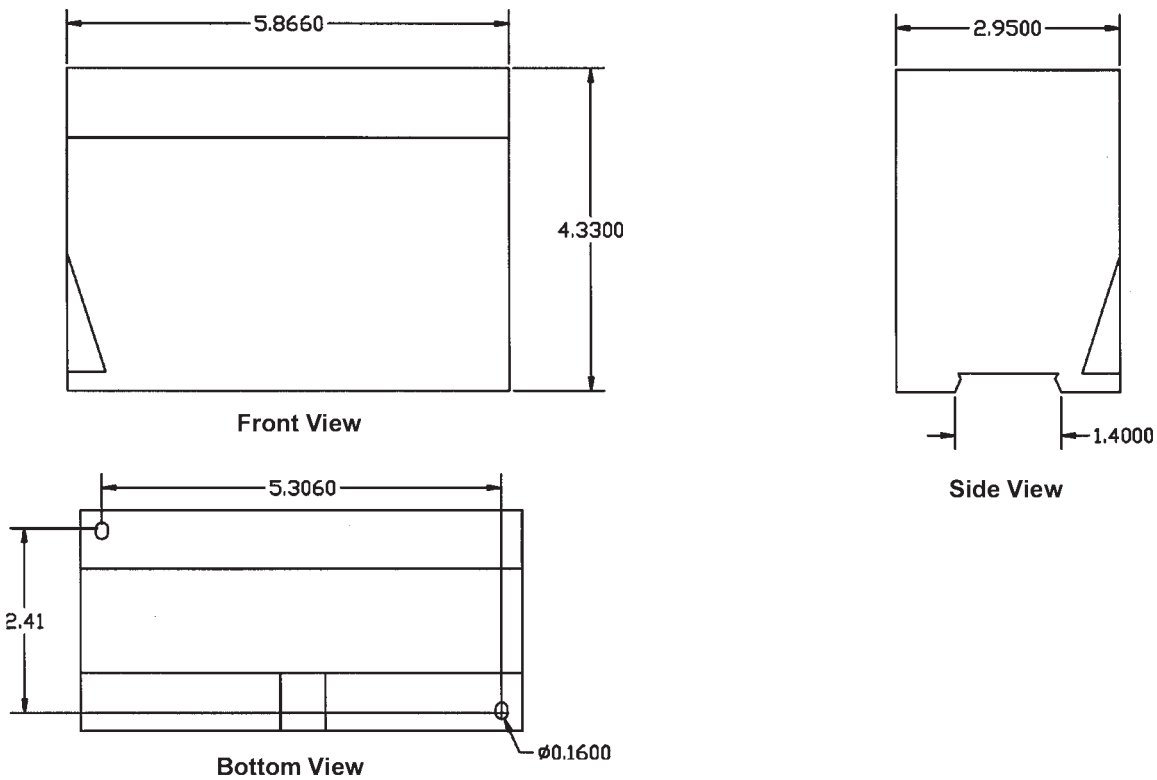

Remote Status Display (RSD)<sup>TM</sup>

Figure 8: RSD Mounting Dimensions

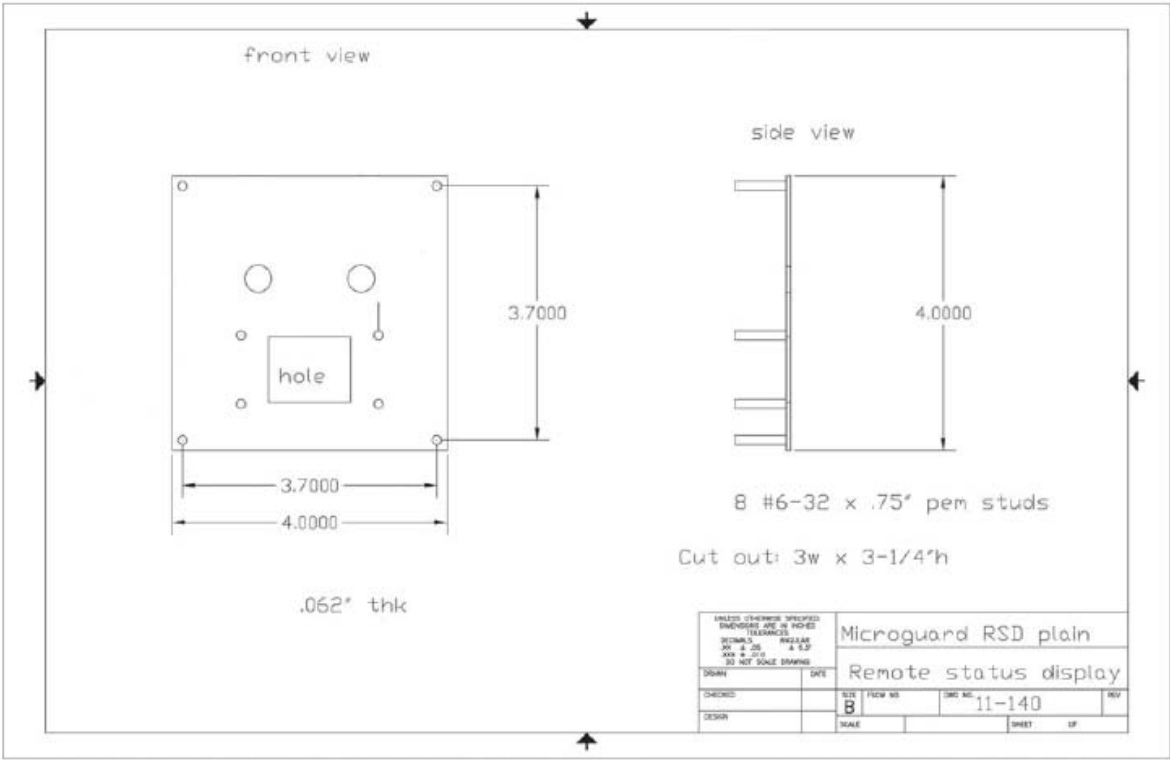
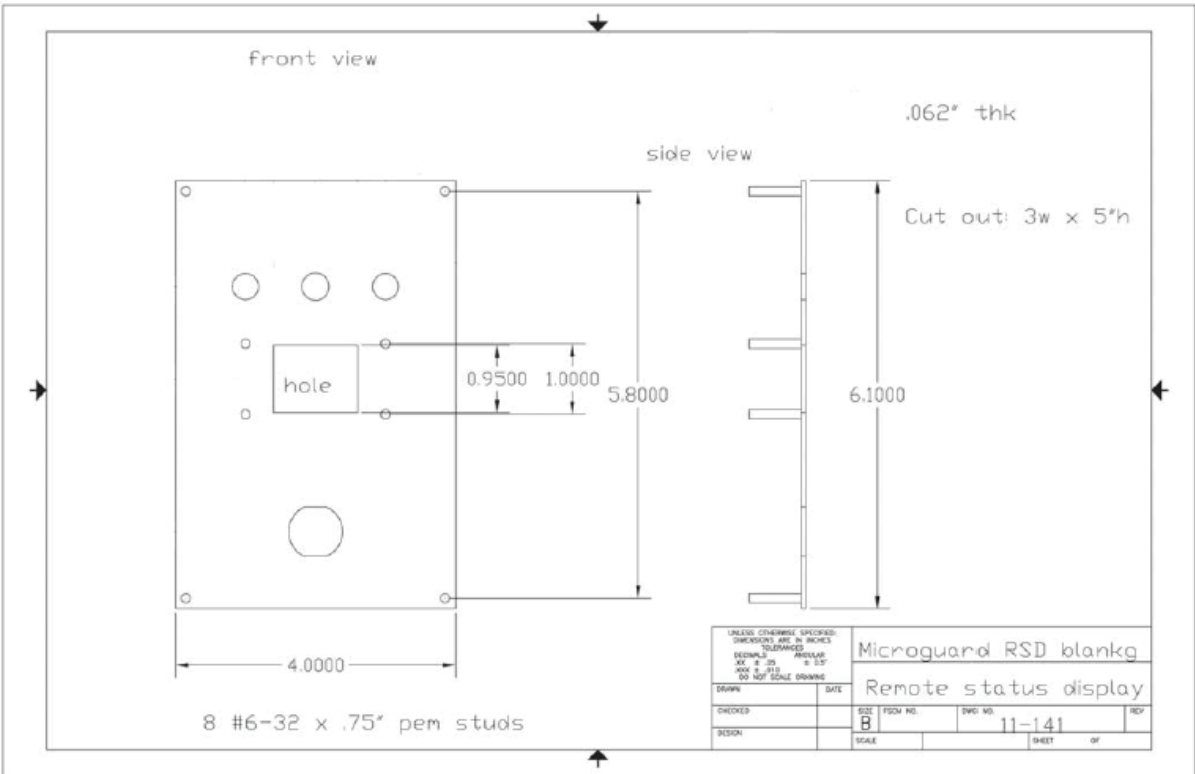

Figure 9: RSD with Floating Blank or Auto Blank Mounting Dimensions



# Accessories

## DIN-rail Controller Module

### Cornering Mirrors

Through the use of cornering mirrors, multiple sides or work envelopes can be guarded which enhance safety and down-time related to mechanical and electrical interlock systems. Be sure to include a reflectivity loss per mirror (15% for MGM, 10% for TRM) when calculating total scanning distance of light curtain.

**NOTE:** Mirrors are surface coated. Wipe surface using only a damp, clean, soft 100% cotton cloth. To replace broken or scratched glass, remove end bracket and slide mirror out with gasket.

**WARNING:** If you are using Auto Blank or Floating Blank options, you may unknowingly create a hole around your machine. Do not use mirrors with blanking unless you need blanking on all guarded sides.

**Table 7: Cornering Mirror Dimensions**

MODEL	DIM A (in/mm) (hole to hole distance)	DIM B (in/mm) (mirror length)	DIM C (in/mm) (total length)
TRM-04 / MGM-04	7.45 / 189	6.25 / 159	8.50 / 216
TRM-08 / MGM-08	11.45 / 240	10.25 / 260	12.50 / 318
TRM-12 / MGM-12	15.45 / 392	14.25 / 362	16.50 / 419
TRM-16 / MGM-16	19.45 / 494	18.25 / 464	20.50 / 521
TRM-20 / MGM-20	23.45 / 494	22.25 / 565	24.50 / 622
TRM-24 / MGM-24	27.45 / 697	26.25 / 667	28.50 / 724
TRM-28 / MGM-28	31.45 / 799	30.25 / 768	32.50 / 826
TRM-32 / MGM-32	35.45 / 900	34.25 / 870	36.60 / 927
TRM-36 / MGM-36	39.45 / 1002	38.25 / 971	40.50 / 1029
TRM-40 / MGM-40	43.45 / 1104	42.24 / 1073	44.50 / 1130
TRM-44 / MGM-44	47.45 / 1208	46.25 / 1175	48.50 / 1232
TRM-84 / MGM-48	51.45 / 1307	50.25 / 1276	52.50 / 1334
TRM-52 / MGM-52	55.45 / 1408	54.25 / 1378	56.50 / 1435
TRM-56 / MGM-56	59.45 / 1510	58.25 / 1480	60.50 / 1537
TRM-60 / MGM-60	63.45 / 1612	62.25 / 1581	64.50 / 1638
TRM-64 / MGM-64	67.45 / 1713	66.25 / 1683	68.50 / 1740

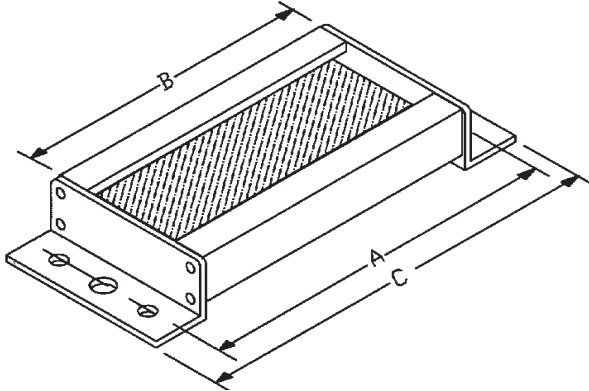

Tolerance: +/- 0.10 inches / .025cm

**Figure 10: Cornering Mirror Dimensions**

#### MGM Dimensions

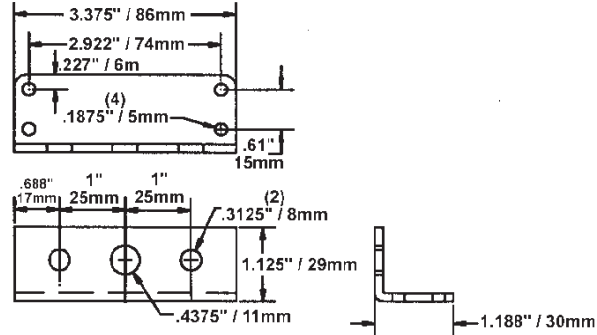

#### TRM Dimensions

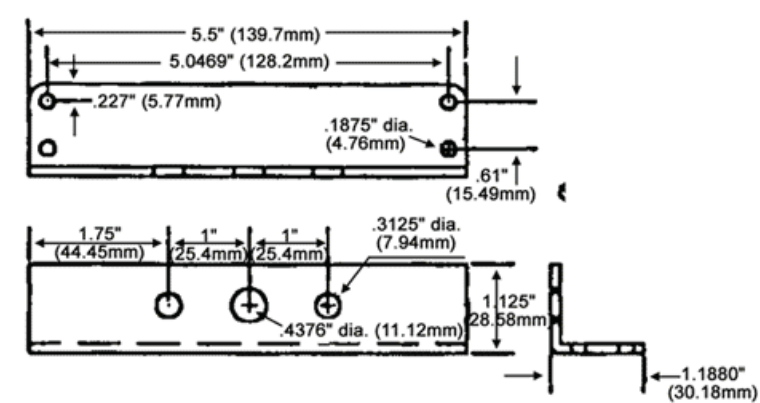



## Pedestal Mounting

The heavy duty, all-welded steel pedestal floor mounts can be used for mounting either the MicroGuard Metal Box or DIN-rail Controller Module or cornering mirrors. Sliding mounts on the pedestal are universal in design and are supplied standard. Unique floating base on pedestal is designed to compensate for uneven floors. Pedestal is fabricated from 12 gauge steel, the base is 1/4" steel plate, and the entire unit is painted OSHA yellow.

Standard height = 72" (model 8000)

Optional height = 96" (model 8096)

NOTE: Do not mount pedestal to floor until you have fully installed your guarding system and know it is operating properly in its current position on the floor.

**WARNING:** Pedestals must be bolted to the floor after installation; they must not be movable.

11-183 Standard Single pedestal mounting bracket

11-184 Special Dual pedestal mounting bracket.  
Has 2 mounting studs 90deg apart.  
Allows both Emitter & Receiver pylon on 1 pedestal. Requires SMB option on pylons.

## Swing-Arm Mounting Bracket

Excellent method of mounting the light guard for press brakes or when the light guard is to be moved for die setups or machine maintenance. Model 9000 consists of three 180-pivot points along with light guard diagonal movement capability for virtually unlimited light guard positioning. Two-inch square tubing 3/16" thick painted OSHA yellow which mounts directly onto the machine housing and makes for a heavy duty yet versatile mounting bracket.

Specify dimensions for sections "B" and "C."

Figure 11: Pedestal Dimensions

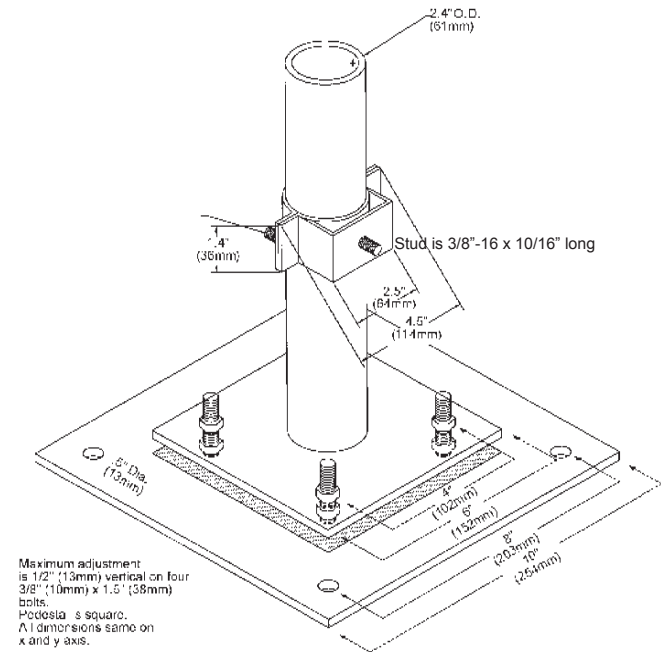
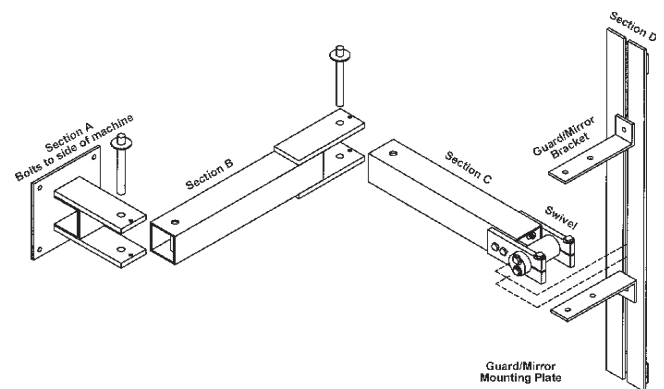

Figure 12: Swing-Arm Mounting Bracket



# Appendix "A"

## Diagnostics & Troubleshooting

### Obstruction or Misalignment

When the curtain is obstructed or misaligned, the display will present four numbers to indicate location of obstruction or misalignment.

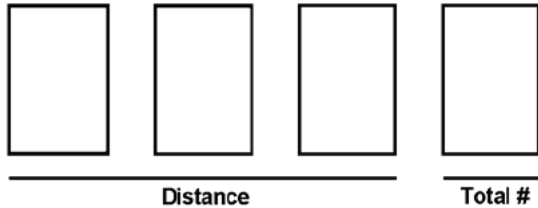

**Distance:** The first three numbers displayed represent (in inches) the first obstructed or misaligned beam on the guard starting from the cable end of the pylon. The third digit is blank for whole inches and "5" for half inches.

**Total #:** The last digit indicates the total number of beams blocked or misaligned. The digit counts in Hexadecimal (0 to F = 0 to 15 beams). A ">" sign indicates more than 15 beams missing.

"A"=10 beams, "B"=11 beams, "C"=12 beams, "D"=13 beams, "E"=14 beams, "F"=15 beams

**Computing Object Size:** To compute an object's size, use the following formula:  $\text{size(inches)} = \text{TOTAL\#} \times 0.5$

This can be used to evaluate an object's size up to 7.5" in diameter.

(i.e., TOTAL# = 3 so SIZE = 1.5")

(i.e., TOTAL# = D so SIZE = 6.5")

**Examples:**

1255 = First obstruction located 12.5" from connector, size of object is 2.5"

05 A = First obstruction located 5.0" from connector size of object is 5.0"

### Error Conditions

When an ERROR message is displayed, the end of the message will display a set of numbers to indicate where along the pylon the problem resides.

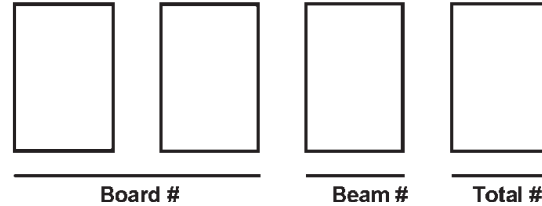

The first two numbers displayed represent the first problem beam on the guard starting from the cable end of the pylon. The third number represents the total number of beams blocked on the guard. Boards inside each pylon are exactly four inches long. Using this you can determine which board in the pylon is bad.

#### Definitions

**BOARD #:** Indicates first board on which a problem was detected (01 to 17).  
(i.e., 01 = board nearest cable connection)

**BEAM #:** Indicates first problem beam on the board indicated above (1 to 8).  
(i.e., 1 = first beam on board, 8 = last beam on board)

**TOTAL #:** Indicates total number of blocked beams on the curtain.  
(i.e., 1 to 9 beams then A to F = 10 to 15 beams)

The Diagnostics Display has two modes of operation: **Status** and **Fault**. If a fault occurs, the display will scroll the fault message until the "FN1" fault reset button is pushed, even if the cause of the fault is corrected and/or you reset the power.

### Status Display Messages

#### Normal Operation

<b>TEST</b>	Testing internal systems
<b>RST</b>	Unit waiting for Push of FN1 (located on control module power supply board middle left hand side)
<b>RDY</b>	Normal operation
<b>RdyE</b>	External relay checking feature active
<b>RdyM</b>	Mute-Out option enabled
<b>RdyL</b>	Latching relay enabled
<b>RdyF</b>	Weld flash enabled (slows down response time of curtain by two)

#### Obstruction

<b>03 &gt;</b>	15 or more beams blocked starting at 3" up from connector pylon
<b>153</b>	3 beams out starting 1.5" up from connector end of pylon.
<b>SBLK</b>	Master and Slave processors do not see blockage.
<b>FLIP</b>	Master and Slave processors keep alternating as to which one sees blockage. When the curtain is obstructed or miss-aligned, the display will present three numbers to indicate location of obstruction or miss-alignment or faulty beam(s). The last digit (4 <sup>th</sup> digit) indicates total number of beams blocked.

#### Floating Blank

<b>FB1</b>	1 beam float maximum
<b>FB2</b>	2 beams float maximum
<b>FB21</b>	2 beams float maximum, 1 beam is blocked
<b>OBST</b>	More than 2 separate objects detected in curtain

#### Auto Blank

<b>AB3</b>	3 beams programmed in as an Auto Blank object
<b>PENT</b>	Mode 1 penetration into guard
<b>SIZE</b>	Total number of allowable blanked beams exceeded during programming
<b>MOVE</b>	Auto Blank object(s) moved, uncovering beam(s)

#### Mute-Out

**MUTE** Guard has gone into by-pass mode

#### Cincinnati Interface

**CINN** Guard has de-energized safety relays, forcing a false blockage mode

### Fault Display Messages

**Resetting Faults:** To reset a fault message, push the FN1 button located on the top of the Controller Module and wait for the message to finish scrolling. Powering down will not clear out faults

All faults appear as scrolling messages. Numbers may appear at the end of the message to indicate where the fault occurred in the pylon itself.

#### 42-019/20 Rxx

Software Revision numbers needed during service. 42-002 MASTER chip; 42-003 SLAVE chip

#### AutoBlank data corrupted

The number of beams found blocked during programming no longer equals what is now in memory. Hardware failure if the fault cannot be cleared.

#### CPU clock failure

Computer has bad clock. Hardware failure.

#### Emitter firing at wrong time xxy

An LED in the Emitter pylon was firing when it was not supposed to. Hardware failure.

#### Emitter length fault

The length of the Emitter pylon does not match the jumper settings inside the Controller Module. Check the L0 to L3 jumpers. Routing Emitter cable away from power cables. Otherwise there is a hardware failure.

#### External contact short

External relay checking option has detected that the external contact did not close during a cycle of the curtain from Green to Red. Check your wiring, your external relay first. Otherwise the opto-input has been burned out.

#### External contact welded or wire cut

External Relay Checking option has detected that the external contact did not open within .25 sec of the curtain going RED. Check your wiring, your external relay first. Otherwise the opto-input has been burned out.

# Appendix "A"

## Diagnostics & Troubleshooting

### External infrared source detected xxy

The curtain (during a blocked condition) detected infrared light from another source. Check for other curtains and make sure the Receiver pylon is not pointing in their direction. Otherwise there is a hardware failure.

### FLIP

MASTER microprocessor is getting intermittent blockage of the curtain due to weak signals and is flipping between GREEN and RED. Re-align the pylons.

### Illegal code

MASTER has come across an illegal machine language code inside the ROM of the CPU (this could indicate a bad CPU chip).

### Improper operation

MASTER has determined that there has been an improper operation in the CPU and has reset for safety.

### Initializing memory

The SLAVE has determined that the EEPROM memory chip does not contain the proper setup values and will attempt to initialize it. This message should only occur during the first time power up. If you get this any other time, it could mean a faulty memory chip or a glitch in the power.

### Internal relay bad/missing

One of the Internal relays has a contact that is not open or closed and is determined to be missing. Check for faulty relay contacts or relay position circuitry.

### Internal relay is not energizing

Internal relay found in the de-energized state when it should have been on. Replace faulty relay or hardware failure.

### Internal relay is stuck on

Internal relay found in an energized state when it should have been off. Replace faulty relay or hardware failure.

### MBLK

MASTER has detected that the pulse width coming from all the receivers is too wide and has determined that the pylons are too close together ( $< 1'$ ). Turn the pylons away from each other slightly.

### Mute-out switch fault

The proper sequence of limit switch closures was not correct and so the unit shut down. This could also be due to excessive noise getting into the PLC lines causing misinformation.

### No ACK from memory

No signal received from memory chips. Faulty memory chip.

### No clock line detected

SLAVE microprocessor could not detect this signal line from the MASTER during a normal scan of the curtain. Check for a faulty circuit in the computer board.

### No data line detected

Slave processor could not detect a signal from the Master processor. Hardware failure.

### No emitter line detected

Slave processor could not detect a signal from the Master processor. Hardware failure.

### No more error codes

This code appears after all previous error codes in memory have been recalled and displayed. Push the FN1 key to restart unit.

### Open LED in emitter pylon xxy

An LED in Emitter pylon was found not lighting. xx indicates board number in 4" increments from circular connector; y indicates beam number of that particular board (1 to 8). Could also be a faulty cable, computer board, or R27 on the computer board has burned open.

### Power failure reset

SLAVE has reset due to either a power loss or some condition that caused the SLAVE to lockup, in which case the watchdog reset it.

### RAM failure

On-board memory has failed a memory test. CPU failure.

### Receiver length fault

The length of the Receiver pylon does not match the jumpers in the Controller Module. Check L0 – L3 in the Controller Module. Route Receiver cable away from power cables. Check the Amp loading passing through the STOP circuit. Otherwise there is a hardware failure.

### Receiver Oscillating xxy

Too many signals were received at one channel input. Light curtains nearby are affecting this curtain. Electrical noise or hardware failure.

### Reset held down

You have held the reset button down too long. The SLAVE is trying to communicate with the EEPROM memory chip.

### **SBLK**

SLAVE microprocessor detected blockage when the MASTER did not. Some of the receiver signals are so weak that the leading edge of the pulse is missed by the SLAVE but the trailing edge is not missed by the MASTER. Re-align the pylons.

### **Serial data corrupted**

The MASTER has requested data from the SLAVE but the check-sum value received does not match the value calculated from the data received. Faulty computer board in the door of the Controller Module, bad CPU chip, or noise glitch.

### **Serial data transfer incomplete**

Data passed between both computers could not be completely transferred. Electrical noise is the main culprit. Hardware failure is the second. Also, check amp loading of the ST OP circuit. Relay sparking can cause faults.

### **Short LED in emitter pylon xxy**

An LED in Emitter pylon was found not firing. xx indicates board number in 4" increments from circular connector; y indicates beam number of that board (1 to 8). Could also be a faulty cable, computer board, or R27 on the computer board has burned short.

### **Slave Found**

Guard has been powered down with a fault code in memory. Push the FN1 button on top of Controller Module to reset fault.

### **Unknown Code**

Garbage data in memory that has no fault code. Push the FN1 button on top of Controller Module to clear.

### **Waiting for reset button**

Master is waiting for user to push the RESET button to start scanning. This indicates that you pushed the RESET button too soon after getting an error message and prevented the SLAVE from saving the error code in permanent memory. You should wait until the message displays one time before pushing the RESET button.

### **Watchdog failure reset**

MASTER has reset due to either a power loss or some condition that caused the SLAVE to lockup, in which case the watchdog reset it.

# Appendix "B"

## Regulations and Guidelines

### OSHA Regulations

#### **1910.217 (C) (3) (iii)** **Safeguarding the Point of Operation**

(iii) A presence sensing point of operation device shall protect the operator as provided in paragraph (c) (3) (i) (a) of this section, and shall be interlocked into the control circuit to prevent or stop slide motion if the operator's hand or other part of his body is within the sensing field of the device during the downstroke of the press slide.

- (a) The device may not be used on machines using full revolution clutches.
- (b) The device may not be used as a tripping means to initiate slide motion.
- (c) The device shall not be constructed so that a failure within the system does not prevent the normal stopping action from being applied to the press when required, but does prevent the initiation of a successive stroke until the failure is corrected. The failure shall be indicated by the system.
- (d) Muting (bypassing of the protective function) of such device, during the upstroke of the press slide, is permitted for the purpose of parts ejection, circuit checking, and feeding.
- (e) Refer to ANSI B11.19-2003 for calculating safety light curtain distance from the point of operation.
- (f) Guards shall be used to protect all areas of entry to the point of operation not protected by the presence-sensing device.

#### **1910.217 (C) (3) (iii)** **Additional requirements for safeguarding**

Where the operator feeds or removes parts by placing one or both hands in the point of operation, and a two hand control, presence sensing device or Type B gate or movable barrier (on a part revolution clutch) is used for safeguarding:

- (i) The employer shall use a control system and a brake monitor which comply with paragraphs (b) (13) and (14) of this section.
- (e) Inspection, maintenance, and modification of presses-
  - (i) It shall be the responsibility of the employer to establish and follow a program of periodic and regular inspections of his power presses to insure that all their parts,

auxiliary equipment, and safeguards are in a safe operating condition and adjustment. The employer shall maintain records of these inspections and maintenance work performed.

#### **1910.212** **General requirements for all machines (covers press brakes, hydraulic and pneumatic machines not covered by mechanical power press standards).**

- (a) Machine guarding - (1)Types of guarding. One or more methods or machine guarding shall be provided to protect the operator and other employees in the machine area from hazards such as those created by point of operation ingoing nip points, rotation parts, flying chips, and sparks. Examples of guarding methods are: barrier guards, two-handed tripping devices, electronic safety devices, etc.

NOTE: These are only partial reprints, refer to your Federal Register for total construction, control reliability and machine guarding requirements for the subject machine being guarded for all applicable OSHA Standards.

### Machine Control Reliability Requirements

#### **Control Reliability**

"...control circuits shall be designed and constructed so that a single failure or fault within the system does not prevent the normal stopping action from being applied to the press when required, or does not create an unintended stroking action, but does prevent initiation of a successive stroke until the failure is corrected" (ANSI B11.1-1988).

"...control shall be designed to prevent initiation of a stroke signal in the event that a failure occurs within the press control" (ANSI B11.2-1982).

"Robots shall be designed and constructed so that any single, reasonably foreseeable failure will not cause hazardous motion of the robot" (ANSI/RIA R15.06-1991).

"...control circuits shall incorporate features to minimize the possibility of an unintended stroke in the event of the failure of the control component to function properly including relays, limit switches, and static output circuits" (ANSI B11.1-1982).



"...control system shall be constructed so that a failure within the system does not prevent the normal stopping action from being applied to the press when required, but does prevent initiation of a successive stroke until the failure is corrected" (ANSI B11.1-1982).

"...the control system shall be constructed so that a failure within the system does not prevent the normal stopping action from being applied to the press when required, but does prevent initiation of a successive stroke until the failure is corrected" (OSHA CFR 1910.217, 1988).

### Safety Guidelines for Management

#### Operational Safety

1. Appoint a Safety Coordinator to be responsible for safety regulations, requirements, and suggestions. He must review and investigate all accidents and "close calls."
2. Establish and issue safety rules. Inform each employee of his responsibilities. Make sure he understands them and knows what is expected of him.
3. A thorough review and an early inspection must be made of existing presses, dies, and point of operation guarding to attain the degree of responsibility required by ANSI B11.1-1988 Safety Standards and Federal State laws. Review what mandatory modifications are necessary.
4. Equipment that is no longer safe and that cannot be economically upgraded should be destroyed.
5. Never allow persons legally under age to operate or assist in the operation of machinery
6. All personnel must be properly trained to eliminate accidents and injuries.
7. Regardless of the operator's experience, education, or language barrier, it is the responsibility of the supervisor to give him a thorough explanation with each new job assignment.
8. No employee should be given a work assignment that he does not fully understand. Only properly instructed and thoroughly trained personnel should be assigned to work on or with any machine.
9. It shall be the responsibility of the employer to provide an adequate, clean, safe, and uncluttered work area around each machine.
10. If a malfunction is reported, stop the machine immediately, correct the problem, then resume production.
11. Investigate all accidents and close calls. Analyze the reason for occurrence. Take action to prevent recurrence. Keep records of the investigation and preventative steps that were taken.
12. Only employees who understand the machines, operation and safety requirements, and who are able to communicate this knowledge should be given the responsibility of instructing and training others to perform as operators.
13. Management must decide that personnel protective safety equipment is required to perform each job safely. Items such as safety glasses, shoes, gloves, helmets, hand pads, spats, protective sleeves and material handling equipment are common in the metal working industry. If noise levels are excessive, protective headsets and earmuffs are recommended.
14. When designing point of operation guarding, the manufacturing process should be weighed heavily in favor of operational safety.
15. Establish safe and convenient material handling methods and procedures.
16. Post in convenient areas the names, addresses, and phone numbers of physicians and hospitals, and members of the organization who are to be called in case of emergency.
17. All equipment must be electrically connected according to the National Electric Code and be consistent with other accepted practices.
18. Provide adequate and proper fire protection equipment.

#### Power Press Guarding

1. Press manufacturers do not know and cannot foresee the magnitude of potential applications of power presses. Therefore, only the press user can determine the type of guards that have to be used in order to perform the job safely. It is the responsibility of the user management to make certain that point of operation guarding and other necessary safety devices are installed. The press should be guarded in such a manner that it is impossible for the operators to place their hands or any other part of the body in the die area.

## Appendix "B"

### Regulations and Guidelines

2. The press user should become thoroughly acquainted with the safety devices commonly employed in power press operations.
3. Feeding devices are strongly recommended, since they remove the operator from the die area, and therefore allow more effective utilization of guards and safety devices.
4. Do not release a press for production before installing and testing all guards and covers.
5. Make frequent evaluation checks of all guarding and devices while the press is running. Correct all unsafe findings immediately.

#### **Power Press Care through Inspection and Maintenance**

1. All maintenance and inspection personnel should be specifically instructed, and must understand proper maintenance and inspection procedures contained in this manual.
2. Set up a daily, weekly, and monthly press inspection program. Use a checklist and verify that the job is done correctly.
3. Establish a preventative maintenance program. Records of all maintenance work performed must be kept.
4. Since all equipment has a limited life, quality maintenance personnel are required to obtain maximum usage of your equipment.
5. Releasing a power press for production following maintenance should be the responsibility of a qualified individual assigned by management.
6. To maintain the original level of press reliability careful inspection of mechanical, electrical, and pneumatic areas must be made. This may give an advance warning of a hazard which then can be corrected to prevent possible injuries and damage.

#### **Safety Enforcement**

In order to have an effective safety program, management at all levels must enforce every safety rule and regulation. Strong disciplinary measures are sometimes required. They should consist of a warning, written reprimand, work suspension, transfer demotion, or possibly a dismissal. All infractions must be reported and recorded. Once an infraction is noted, it shows that an unsafe practice or condition has existed. This may be the result of poor planning or improper training

and instructing. The reason for the infraction should be analyzed in order to take corrective action.

#### **Supervisor Training**

It should be the responsibility of management to instruct their supervisors on safety, giving job instructions, supervising operators, determining accident causes, and building safety attitudes among the machine operators. Accidents can occur due to inadequate training of supervisors.

#### **Operator Training**

It shall be the responsibility of management to insure proper training of operators. A specific training program should be instituted to instruct the operator in safety, proper usage of the equipment, and correct operational procedure in performing each and every job. In addition to the supervisor, the operator should be familiar with the proper guarding of the point of operation. Never permit an operator to start a job without complete instructions from his immediate supervisor.

## Pylons

Figure 11: Pylon Replacement Part Numbers

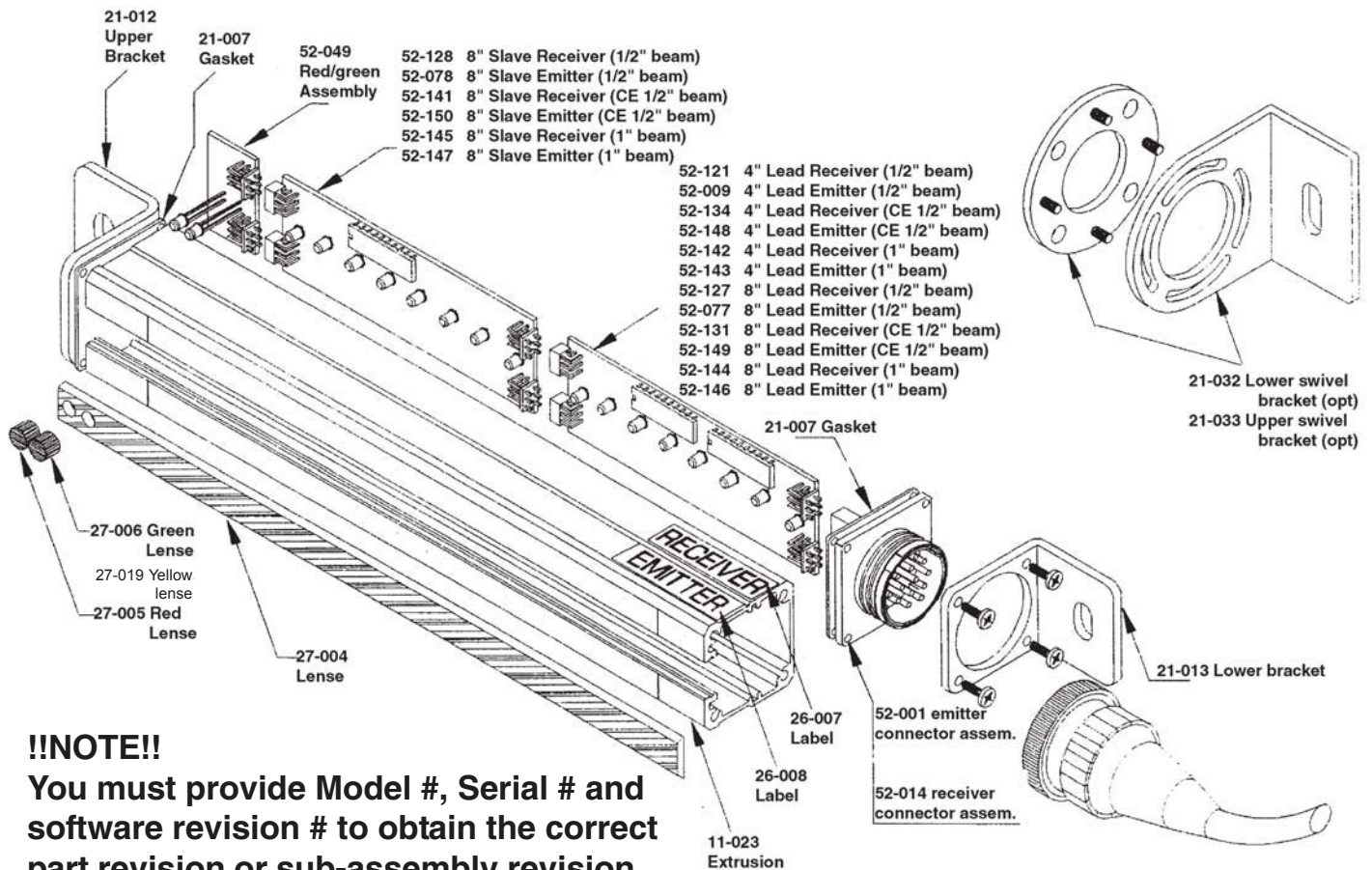

### !!NOTE!!

**You must provide Model #, Serial # and software revision # to obtain the correct part revision or sub-assembly revision. An individual Part# may have been revised since your unit was purchased.**

- 42-019 Master Computer Chip (must specify Model#)(square or rectangular)
- 42-020 Slave Computer Chip (same as above)
- 53-078 Din-Rail Replacement Controller (must specify Model#)
- 52-263 Replacement Extrusion (painted Yellow or Blue, with lens)
- 26-058 Din-Rail Controller Overlay
- 26-069 Din-Rail Controller Overlay (Auto Blank)
- 26-070 Din-Rail Controller Overlay (Floating Blank)
- 32-001 Original Safety Relay (Clear, White, or Blue in color)
- 32-098 New Safety Relay (Green)
- 20-022 1A slo-blo smt fuse
- PT Polycarbonate protective Tube (with Viton Seals) (Requires Swivel mount brackets)

- 11-183 Standard Single pedestal mounting bracket
- 11-184 Special Dual pedestal mounting bracket.  
Has 2 mounting studs 90deg apart. Allows both Emitter & Receiver pylon on 1 pedestal. Requires SMB option on pylons
- 21-019 Rubber Shock-Mount (Male-Female) 1" dia x 1" tall 5/16-18 thread



### **WARRANTY**

Manufacturer warrants that this product will be free from defects in material and workmanship for a period of two years from the date of shipment thereof. Within the warranty period, manufacturer will repair or replace such products which are returned to it with shipping charges prepaid and which will be disclosed as defective upon examination by the manufacturer. This warranty will not apply to any product which will have been subject to misuse, negligence, accident, restriction, and use not in accordance with manufacturer's instructions or which will have been altered or repaired by persons other than the authorized agent or employees of the manufacturer.

### **DISCLAIMER**

The provisions of the paragraph "Warranty" are the sole obligations of the manufacturer and exclude all other warranties of merchantability, expressed or implied.

Further, there are no warranties which extend beyond the above warranty

### **LIMITATION OF LIABILITY**

In the event of any claim or breach of any obligations of manufacturer under any order, whether expressed or implied, and particularly in the event of any claim or a breach of the warranty or warranties contained in the paragraph "Warranty" or of any other warranties, expressed or implied which might, despite the paragraph entitled "Disclaimer," be determined to be incorporated in any order the company shall under no circumstances be liable for any consequential or special damages, either in law or in equity or for losses or expenses or claims for the same arising from the use of, or inability to use, the products of the manufacturer for any purpose whatsoever.

**WARNING:** The entire machine safety system must be tested at the start of every shift. Machine testing should include: (1) proper machine operation and stopping capability; and (2) verification of proper installation and settings of all point of operation guards and devices before the operation is released for production.



## **Sales and Marketing Offices**

### **United States**

Pinnacle Systems, Inc.  
P.O. Box 100088  
Pittsburgh, PA 15233

Toll Free Number: 800-569-7697  
Direct Number: 412-262-3950  
Fax: 412-262-4055

### **Canada**

Pinnacle Systems, Inc.  
8-1734 Orangebrook Court  
Pickering, Ontario L1W 3G8

Toll Free Number: 888-285-8885  
Direct Number: 905-831-1111  
Fax: 905-831-4064

## **Customer Service: (630) 443-8542**

We have designed our equipment to the very highest performance and safety standards known to the current technological state of the art, as evidenced by our U.S.A. and foreign patents issued and pending. However, the installation, usage, suitability and fitness of our equipment for any purpose, known or unknown, is interdependent upon the performance of other equipment not manufactured, installed, secured or maintained by Pinnacle Systems, Inc.

We cannot and do not accept responsibility for any overall system performance when factors, such as these, are beyond our control.

**[www.pinnaclesystems.com](http://www.pinnaclesystems.com)**

**[sales@pinnaclesystems.com](mailto:sales@pinnaclesystems.com)**  
**[service@pinnaclesystems.com](mailto:service@pinnaclesystems.com)**