

microGUARD[®]

Installation Manual for the Metal Box Controller Module

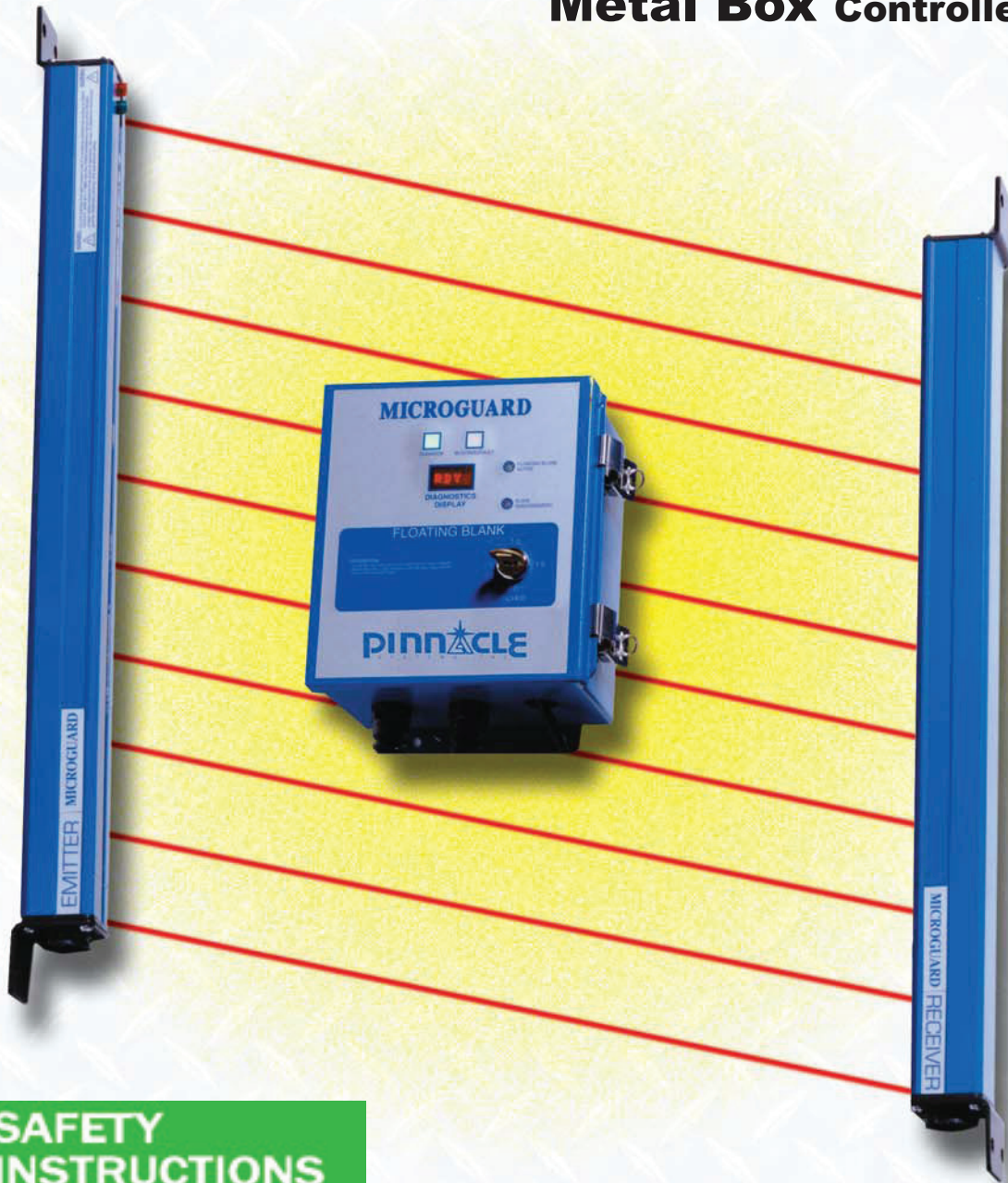

SAFETY INSTRUCTIONS



WARNING

Read and fully understand this manual. Failure to do so could result in death or serious injury.





DANGER indicates a hazardous situation which, if not avoided, will result in death or serious injury.



WARNING indicates a hazardous situation which, if not avoided, could result in death or serious injury.



CAUTION indicates a hazardous situation which, if not avoided, could result in minor or moderate injury.



NOTICE is used to address practices not related to physical injury.



Safety Instructions (or equivalent) signs indicate specific safety-related instructions or procedures.

microGUARD®

Metal Box Controller Module Installation Manual

Pinnacle Systems, Inc.
3715 Swenson Avenue
St. Charles, IL 60174

P/N: 28-006r10.0

Customer Service: 630-443-8542 (CST)
(Please have Model #, Serial #, and Software Rev # Available)

Sales and Marketing: 800-569-7697 (EST)

www.pinnaclesystems.com • sales@pinnaclesystems.com • service@pinnaclesystems.com

Proper Usage and Limitations

⚠️ WARNING

The information disclosed herein includes proprietary rights of the manufacturer. Neither this document nor the information disclosed herein shall be reproduced or transferred to other documents, used or disclosed to others for manufacturing purposes, or for any other purposes, except as specifically authorized in writing by the manufacturer. If this manual is supplied in connection with the sale or delivery of manufacturer's equipment, it is to be used solely for maintenance, repair, or installation of such equipment.

The MicroGuard was manufactured in the United States. The Installation Manual was printed in the United States.

You must read and fully understand the following information pertaining to the proper use and limitations of your Microguard:

- The MicroGuard must be installed by qualified personnel only.
- The MicroGuard must NOT be used on full revolution presses or any machine that cannot be commanded to stop at any time.
- You must NOT wire the Safety Output contacts of the MicroGuard to an external relay unless you use the External Relay Checking feature.
- The mechanical power press on which the MicroGuard is installed must meet ANSI B11.1-2009 and OSHA 1910.217 regulations. These include inspection and maintenance procedures that must be followed to comply with the regulations. The manufacturer will NOT take responsibility for improperly maintained machinery.
- Point of operation safeguarding is defined in ANSI B11.19-2010. This regulation is used to determine a safe distance to place your MicroGuard. The manufacturer takes no responsibility for injury as a result of improper safeguarding or improper safe distances.
- The MicroGuard may not be able to safely stop a press which has a faulty stopping mechanism. The manufacturer cannot be held responsible for an improperly maintained or faulty stopping mechanism.
- The MicroGuard must be checked before put into operation. Follow instructions provided in this manual for procedures on how to do this.
- The MicroGuard should never be modified or repaired except by qualified personnel and upon authorization of the manufacturer. Never operate machinery that is not in full working order.
- Make sure that all maintenance people, machine operators, die-setters, foreman, and supervisors have read and understood this manual and all procedures have been and will be followed.

- All procedures in this manual must be followed. The manufacturer cannot take responsibility for operation if all procedures and warnings in this manual are not followed.

Warranty

Manufacturer warrants that this product will be free from defects in material and workmanship for a period of two years from the date of shipment thereof. Within the warranty period, the manufacturer will repair or replace (at our discretion) any product that is disclosed as defective upon examination by the manufacturer and is returned with shipping charges prepaid. This warranty will not apply to any product that has been subjected to misuse, negligence, accident, restriction, and use not in accordance with manufacturer's instructions or which will have been altered or repaired by persons other than the authorized agent or employees of the manufacturer.

Disclaimer

The provisions of the warranty are the sole obligations of the manufacturer and exclude all other warranties of merchantability, expressed or implied. Further, there are no warranties that extend beyond the above warranty.

Limitation of Liability

In the event of any claim for breach of any obligations of the manufacturer under any order, whether expressed or implied, and particularly in the event of any claim of a breach of the warranty or warranties contained in the paragraph "Warranty" or of any other warranties, expressed or implied which might despite the paragraph entitled "Disclaimer," be determined to be incorporated in any order, the company shall under no circumstances be liable for any consequential or special damages, either in law or in equity, or for losses or expenses or claims for the same arising from the use of, or inability to use, the products of the manufacturer for any purpose whatsoever.

We have designed our equipment to the very highest performance and safety standards known to the current technological state of the art. However, the installation, usage, suitability, and fitness of our equipment for any purpose, known or unknown, is interdependent upon the performance of other equipment not manufactured, installed, or secured or maintained by the manufacturer. We cannot and do not accept responsibility for any overall system performance when factors, such as these, are beyond our control.

We will not supply individual component parts of any circuit board but will supply the individual circuit board complete. Individual detectors or emitters are available as a complete tested unit.

⚠ WARNING

The entire machine safety system must be tested at the start of every shift. Machine testing should include: (1) proper machine operation and stopping capability; and (2) verification of proper installation and settings of all point of operation guards and devices before the operation is released for production.

Fill this Information out Immediately

(It will be needed in the event you need assistance)

Purchase Date: _____

Purchased From: _____

Model No.: _____

Serial No.: _____

Options: _____

Microprocessor Revision No.: _____

Table of Contents

Introduction	iv
Theory of Operation	iv
The System	iv
System Safety	iv
Immunity to EMI/RFI	v
CE Approved	v
Specifications	1
Standard Features	
Auxillary Output Contact	2
Cincinnati Interface	2
External Relay Check	2
Standard Output Contacts	3
Fault Relay Output	3
Optional Features	
Auto Blank	4
Emergency Stop Input	5
DeviceNet	5
Floating Blank	5
Depth Penetration Factor	5
Guarding Mute-Out	6
Latching Relays	6
Installation Procedures	7
Resetting the MicroGuard	8
Alignment Procedure	9
Operations	10
ANSI Standard B11.19.2010	11
Safeguarding with Mechanical Guards	12
Light Curtain Testing Procedure	12
Controller Module Setup	13
Single Pylon Set Controller Module Jumper Settings	14
Multiple Pylon Set Controller Module Jumper Settings	15
Wiring	16
Swivel Bracket Dimensions	17
Pylon Dimensions (by model) (Swivel)	18
Additional cable information (Swivel)	18
Fixed Bracket Dimensions	19
Pylon Dimensions (by model) (Fixed)	19
Additional cable information (Fixed)	19
Dimensions	
Physical Dimensions of Swivel Bracket	17
Physical Dimensions of Swivel Bracket	18
Physical Dimensions of Fixed Bracket	19
Controller Module	20

Accessories

Cornering Mirrors	21
Pedestal	22
Swing-Arm Mounting Bracket	22

Appendix A: Diagnostics & Troubleshooting

Diagnostic Indicator Lights	A-1
Obstruction or Misalignment	A-1
Error Conditions	A-1
Status Display Messages.....	A-2
Fault Display Messages.....	A-2

Appendix B: Regulations and Guidelines

OSHA Regulations	B-1
Machine Control Reliability	B-1
Safety Guidelines and Management	
Operational Safety	B-2
Power Press Guarding.....	B-3
Power Press Care through Inspection and Maintenance.....	B-3
Safety Enforcement	B-3
Supervisor Training	B-3
Operator Training.....	B-3

Appendix C: Replacement Parts

Controller Module Replacement Parts	C-1
Pylon Replacement Parts	C-2

Appendix D: USB Diagnostic Codes

Model MG or DR USB Diagnostic Codes	D-1 to D-2
---	------------

Table of Contents

Figures

Figure 1:	Wiring External Relays	2
Figure 2:	Bottom Board Inside Control Box.....	6
Figure 3:	4 Sided Guarding with Dual Stud Guard Brackets, TRM Mirrors and Model #8000 Pedestals	9
Figure 4:	Minimum Object Sensitivity and D(pf).....	11
Figure 5:	Controller Module (Lower Board).....	13
Figure 6:	Controller Module Jumper (Upper Board).....	14
Figure 7:	Multi-pylon Controller Module Connector/Jumper Detail	15
Figure 8:	Controller Module Wiring Diagram.....	16
Figure 9a:	Swivel Bracket Dimensions.....	17
Figure 9b:	Swivel Bracket Dimensions, pylon dimensions (by model), and additional cable information	18
Figure 10:	Fixed Bracket Dimensions, pylon dimensions (by model), and additional cable information.....	19
Figure 11:	Controller Module Dimensions	20
Figure 12:	Cornering Mirror Dimensions	21
Figure 13:	Pedestal Dimensions	22
Figure 14:	Swing-Arm Mounting Bracket Dimensions.....	22
Figure 15:	Controller Module Replacement Parts	C-1
Figure 16:	Pylon Replacement Parts	C-2

Tables

Table 1a:	.5" Beam Spacing Pylons.....	5
Table 1b:	1" Beam Spacing Pylons.....	5
Table 2:	Mechanical Guards	12
Table 3:	Controller Module Connection Chart (Lower Board).....	13
Table 4:	Single Pylon Set Controller Module Jumper Chart	14
Table 5:	Multiple Pylon Set Controller (DUAL - SC) Module Length Jumper Chart.....	15
Table 6:	Controller Module Dimensions	20
Table 7:	Cornering Mirror Dimensions (MGM & TRM).....	21

The Microguard is the latest in infrared safety curtain technology. Contained in the main housing (Controller Module) is a diverse redundant architecture that is designed to detect internal failures in the Emitter pylon(s), Receiver pylon(s), and the Controller Module which will immediately send a "STOP" command to the machine, thus being "FAIL-SAFE." Failures are immediately reported on the diagnostic message display for immediate evaluation.

Diverse redundancy means that there are at least two ways to detect a system failure, two ways to shut it down, and that the two methods of detection and shut down use different techniques. This eliminates the chance an inherent fault in one circuit will effect the other. For example: The stop circuit output contacts run through two relays and both are monitored for correct position through a second set of contacts on each relay. A special circuit monitors those contacts, but a different circuit (a test circuit) monitors the first circuit to make sure that it is functioning correctly. Two different microprocessors isolated from one another each monitor the same signals and monitor each other. Either microprocessor can turn off the output relays, but it requires both to turn them on. Special watchdog circuits on the microprocessors and on the output relay circuits prevent an unsafe condition by turning off both outputs relays should either or both microprocessors become erratic.

With the aid of advanced microprocessor technology, the MicroGuard can not only detect a fault in the light curtain but spell out the exact problem. This advancement is a great help during alignment, use, and servicing of the light curtain. It not only can detect shorted and open infrared emitters, but indicate which emitters have failed, allowing the faulty board to be replaced.

Built into the MicroGuard is an optically coupled external relay check which can detect open or short circuits, a Cincinnati Interface, provision for auxiliary output contacts, and external voltage check input. The power supply is designed to accommodate most voltage requirements, from DC to AC (*see Specifications*).

As the MicroGuard is a single function device, that of sensing an unauthorized intrusion into a guarded area while simultaneously determining that it is capable of sensing such an intrusion, any internal malfunction will manifest itself with a RED condition shut down.

Theory of Operation. The MicroGuard guards an area by projecting a curtain of infrared light across it. It forms a curtain by utilizing infrared emitters in line very close together on .5" or 1" centers. This close spacing makes it *impossible* to place a body part through the curtain without detection. For every infrared emitter there is an infrared detector directly opposite. When an obstruction

is placed between them, the beam is broken and the absence of a beam is observed by the Controller Module which de-energizes the output relays and opens the circuit it is connected to.

The System. The MicroGuard employs infrared technology in a small sealed NEMA 4 aluminum housing which provides harmless invisible protection and an unobstructed view of the guarded area. The Microguard consists of three parts: an Emitter pylon(s), Receiver pylon(s), and Controller Module. The Emitter pylon(s) contains infrared light emitting diodes spaced .5" or 1" apart down the entire length of the pylon. The Receiver pylon(s) contains an equal number of infrared detector's and transistor receivers also spaced .5" or 1" apart. The Controller Module contains diverse redundant technology that includes two different microprocessors, self-checking circuitry, power supply, safety output contacts, and a diagnostics display.

System Safety. The MicroGuard employs diverse redundant technology that provides a backup for every system that could cause an unsafe condition. Upon power up, all systems are checked before activating the output relays. Once the unit passes the initial tests and activates the system it is then tested by both microprocessors and other circuits once per scan of the light curtain. All signals are presented to both microprocessors, but are isolated from one another to prevent a failure of one microprocessor should the other crash. Other circuits detect short circuits, open circuits, proper voltage, proper oscillation, etc. The use of special dual force guided safety relays assure that if one fails, the other can safely shut down the unit. Additionally, watchdog circuits on the relays prevent an unsafe condition even if both microprocessors failed. All the standard and optional features that run on the MicroGuard are designed with safety in mind:

The Floating Blank option allows only one object to be placed into the light curtains field of view. Even if the object is smaller than the allowed size, a second object will cause the unit to go RED.

The Auto Blank option programs in the exact size and location of an object automatically and thus can detect any movement in the object and shut down the light curtain, which must be reset with a key.

The External Relay Check can detect both an open or a short in the external relay or its wiring. The standard Cincinnati Interface provides a means to assure that the light curtain can open up its output relays between press cycles.

Introduction

Immunity to EMI/RFI. The entire system is shielded, including the pylon cables. The use of MOV's, filters, and chokes make it immune to the noise found in the industrial environment. Even the software embedded into the dual microprocessors is written to cope with a noisy environment.

CE Approved. CE approval was third party certified by UL / DEMKO to IEC61496-1,-2. CE approved units offer +/-2deg beam angle, which is tighter than the standard Microguard.

Specifications

Metal Box Controller Module

Input Power

18 to 33 VDC @ 10 W (optional)
90 to 140 VAC @ 12 W (standard)
128 to 240 VAC @ 12 W (optional)
All AC voltages work with 50 or 60 Hz

Fuses

AC power: 1 AMP Slow Blow (250VAC)
DC power: 1 AMP Fast Blow

Output Circuits (all isolated)

Terminals #12-13: N.O. (held closed when Green) control reliable dry STOP circuit, wired through K1 & K2 relays. 4A @ 120vac recommended max

Terminals #14-15: N.O. (held closed when Green) control reliable dry STOP circuit, wired through K1 & K2 relays. 4A @ 120vac recommended max

Terminals #9-10-11: N.O. (held closed when Green) – common – N.C. (held open when Green) dry auxiliary circuit, wired through K3 relay. 4A @ 120vac recommended max

Alarm + - : N.O. (held closed when powered and NO FAULTS) dry auxiliary circuit, wired through K4 relay. 4A @ 120vac recommended max

WARNING

For Older Control boxes prior to October 2007: Both terminals #12-13 and #14-15 must be used to achieve a control reliable STOP circuit. Newer control boxes can use either or both sets of terminals.

Indicators

External:

OK/CLEAR	Green
BLOCK/FAULT	Red
AUTO/FLOAT ACTIVE	Yellow
SLAVE DISAGREEMENT	Red

The Diagnostics Display is a four-digit alphanumeric with scroll

Internal:

+12V (RED) D2	CINN INT. (GRN) D10
+5V (YEL) D4	EXT RELAY (GRN) D11
+5V (YEL) D3	-5V (GRN) D17
	FAULT RELAY (GRN) D21

Construction:

Control Unit: All 18 Gauge painted steel NEMA 12 lockable box with sealed front panel and sealed cable entry fittings (8 lbs.).

Pylons: Heavy-duty aluminum extrusion NEMA 4. Replaceable IR lens. Sealed bulkhead positive locking circular connectors. (Optional polycarbonate protective tube guards).

Cables: Emitter 20' Receiver 8' (supplied standard). Shielded PVC 22 AWG cable (optional cable lengths available).

Temperature Range 32° to 120° F

Dimensions

Controller Module: (see Dimensions)

Pylons: 1.45" (36.83mm) square (see Dimensions)

Beam Spacing

.5" (12.7mm) standard
1" (25.4mm) (optional). The Floating Blank option changes the effective beam spacing.

Minimum Object Sensitivity:

.5" (12.7mm) beam spacing is .55" (14mm)
1" (25.4mm) beam spacing is 1.18" (30mm)

Response Time < 30 mSec total

Scanning Frequency 5.9 KHz

Shock Tested to withstand high vibration applications.

Self-Checking every 20 milliseconds

Scanning Distance All units are supplied standard with a 20' (6.1m) scanning capability. Extended range units are available and must be specified -- 50' maximum (15.2m).

Maximum Operating Distance Stated as last two digits in model number.

Auxiliary Output Contact (K3)

Description: K3 relay uses the same driver circuitry as the K1 relay, but has its own relay checking circuitry. This means that you should never use the K3 relay in series with the K1 relay unless you use K2 in another stop circuit.

Usage: K3 has both N.O. and N.C. outputs off the same common. This can be used in conjunction with the standard output contacts. Never just use K3 by itself or with K1.

- N.O. contact is closed when the curtain is GREEN.
- N.C. contact is open when the curtain is GREEN.

Cincinnati Interface

Description: Provided to allow an external device to determine if the light curtain is still capable of shutting down the safety control circuit. The Cincinnati Interface allows an external device to override the light curtain, initiate a RED condition, and open up the standard output relay contacts.

Application: Cincinnati Press, PLC

Usage:

Type 1: The press interface provides 24VDC when it wants the guard to de-energize (go RED). Connect this press signal to Terminal #5 and Ground to Terminal #6.

Type 2: The press interface provides Ground when it

wants the guard to de-energize (go RED). Connect this signal to Terminal #6 and attach nothing to Terminal #5. You must install the jumper J8 (bottom board).

(see *Installation Procedures*, "Controller Module Setup")

External Relay Check

Description: Allows the MicroGuard to monitor a pair of external relays in series using the external relays secondary set of DRY contacts, **provided that they are N.C. and captive contacts**. This captive or force-guided contact will maintain the identical position as the primary set of contacts on the external relays, except that the secondary set of contacts are wired up to signal the reverse of the primary. (i.e., primary are N.O., secondary are N.C.) The circuit looks for both closure and opening of the external relay contacts. This system is the only safe External Relay Check.

Application: Monitoring external relay contacts for shorts or opens.

Usage: Follow Figure 1 for wiring your external relays. **You must first activate this feature by using the spare jumper and placing it across J19 labeled EXT (door board)**. This system requires that both N.C. relay contacts be wired in series then back to the terminals inside the Controller Module. Relay contacts must be DRY contacts. Both external relay contacts must be closed when the light curtain is RED within .25 sec or an

Figure 1: Wiring External Relays

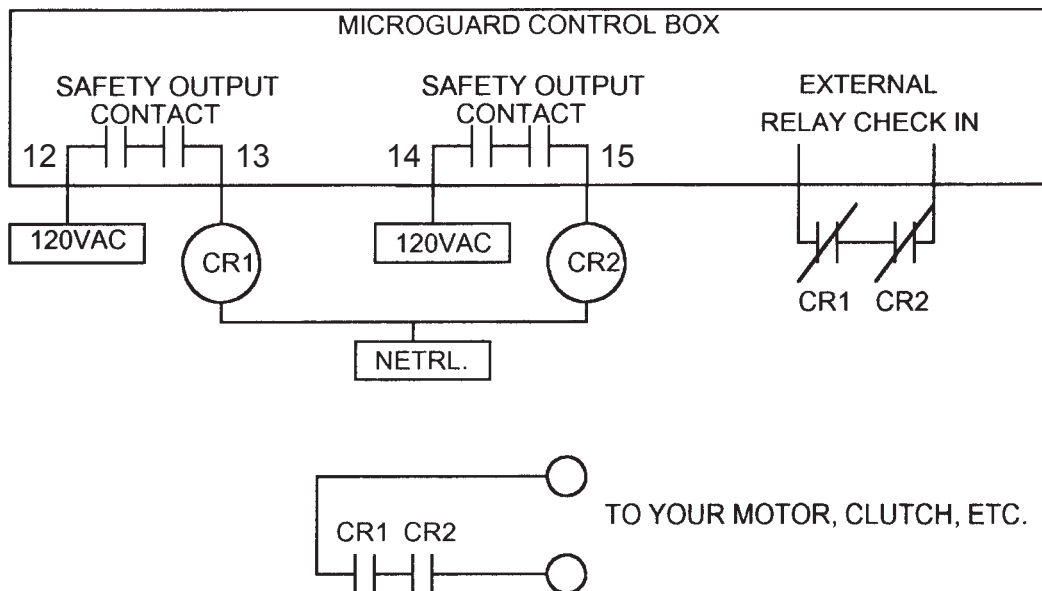

error will occur (this detects an open or a contact weld). When the light curtain goes GREEN it will record the opening of the external relay. If the light curtain goes RED again without ever sensing the opening of the external relays, an error will occur (this detects a short or failed relay) and cause the light curtain to lock up and must be powered down to clear the error. A Red LED (D14) will light up when external contact is closed (see *Installation Procedures, "Controller Module Setup."*)

Captive Contact Definition: one pole inside the relay **always** maintains the identical position to the other pole. (i.e., if one pole contact welds closed, the other pole remains closed even when the relay coil is de-energized.)

Standard Output Contacts (K1 & K2)

Description: Both K1 and K2 relays each have their own relay driving circuitry and relay checking circuitry and are fully independent of each other having their own output terminals. The MicroGuard checks the position of all the relays and shuts them all down if any are found in the wrong position. In order for the system to remain safe during a single failure of one relay, you must be using the relays such that the second relay can still shut the system down if the first one ever fails. This can either be by wiring both relays in series or using both relays separately in two control circuits.

Usage: K1 and K2 have separate outputs and both must be used either together in series with your stop circuit or separately in two stop circuits. K1 and K2 outputs are N.O. and close when the curtain is GREEN only.

Fault Relay Output

Description: It will not change states due to curtain blockage.

Application: Can be used to signal a remote station of an unexpected machine shut down.

Usage: The fault relay provides a dry contact that is open when good and closed when a fault or loss of power occurs. Use the alarm contacts on the power supply board. The dry contact is isolated up to 120VAC.

To Activate: Install jumper on J17 (bottom board) top 2 pins. Install jumper on J9 (door board) between Latch and Close pins (left side). This feature will disable remote latching. D21 will light up to show the relay is active.

Auto Blank [patent # 5,243,183]

Description: Allows user to program the exact size and location of an object (i.e., a conveyor, table, work piece, etc.) automatically and can detect any movement in the object causing the light curtain to shut down.

Application: With the obstruction in place, turn the key switch from “OFF” to any mode of operation. If the object(s) do not exceed the total allowable size, the unit will energize the safety outputs.

Standard Operation: If the obstruction is moved or removed, the unit will issue a “MOVE” fault, but will re-energize the safety outputs when the obstruction is returned to the original position. Standard operation allows for a total of eight beams to be blocked anywhere in the curtain (they do not have to be next to each other).

Optional Operation: If the obstruction is moved or removed, the unit will issue a “MOVE” fault and lockup, requiring you to re-program the obstruction.

Troubleshooting: If you get a “MOVE” fault when the obstruction did not move, it is possible that you are just barely covering a beam and either vibration or reflections are causing the beam to become uncovered. The uncovered beam then causes a fault.

To Activate Feature: This feature must be ordered and requires exchanging the computer chips (see *Installation Procedures*, “Controller Module Setup”).

⚠ WARNING Leave key switch in OFF/RESET position while installing, setting up, and testing the light curtain. Use Auto Blank only after you are able to get a clear signal from the curtain with no obstruction.

The term “Auto Blank” is an abbreviation which stands for Automatic Programmable Beam Blanking. Auto Blanking is controlled by a multi-position keyswitch and has three distinct modes of operation:

1) **Must be reset if auto blank obstruction moves or guard penetrated.** The AUTO BLANK obstruction must remain in its exact location permanently. Any movement in the AUTO BLANK obstruction and/or additional guard penetration will latch the light curtain in a RED condition and must be reset via the keyswitch.

NOTE: If no obstructions were programmed in, the guard will still latch in a RED condition should the guard be penetrated.

2) **Must be reset if auto blank obstruction moves.** The Auto Blank obstruction must remain in its

exact location permanently. This works like Mode 1 except guard penetrations will not latch in a RED condition.

3) **Mode 2 with floating blank.** This mode works like Mode 2 with the addition of a Floating Blank which is set to allow a one beam float (see *Optional Features*, *Floating Blank*”).

NOTICE

If no obstructions were programmed in, the guard will still allow a one beam float.

Programming: To program, turn the keyswitch into the OFF/RESET position and place the obstruction(s) in the guarded area. Now, turn the keyswitch into the desired mode of operation. The exact size and location of the object(s) are now in memory. The Depth Penetration Factor D(pf) must be set to account for the one beam float (see *Optional Features*, “*Floating Blank*”).

Diagnostics Display

- AB** Auto Blank detected an object (the number indicates the size of the object).
- RDY** No objects programmed in, keyswitch in Mode 1 or 2.
- FB** No objects programmed in, keyswitch in Mode 3
- SIZE** Obstruction size exceeded a total of eight beams.
- PENT** Penetration of the light curtain occurred while keyswitch was in Mode 1.
- MOVE** Auto Blank obstruction moved.

⚠ CAUTION

Place Auto Blank keyswitch into OFF/RESET position and remove any obstructions while aligning light curtain. Do not use Auto Blank until light curtain is correctly aligned (see *Installation Procedures*, “*Alignment Procedure*”).

The keyed selector switch is designated to be supervisory controlled. After installation, the safety key should be removed and controlled only by the safety supervisor or authorized plant personnel.

SAFETY INSTRUCTIONS

Emergency Stop Input(s)

Description: This option utilizes two normally-closed emergency stop contacts to achieve a Category 4 safety level, per EN 954-1. If either or both emergency stop contacts open, power to the safety output relays is removed, causing the relays to de-energize and send a stop signal to the guarded machine.

Application: This protects against a safety switch contact failure or wiring fault. A contact failure or wiring short will inhibit the system reset, causing the system's Diagnostic Message Display to indicate an Emergency Stop Input Failure.

Usage: Wire one N.C. contact between Terminal #1 and #4. Wire the second N.C. contact between Terminal #3 and #4 (located on power supply board). This option cannot be used with Mute-Out. Alternative option: Wire first N.C. contact between Terminal #6 and #4. Wire second N.C. contact between Terminal #7 and #8. This option cannot be used with Cincinnati or External relay checking features. To reset ESTOP: Close both ESTOP inputs, then use the latching relay reset input to clear ESTOP fault (cycle closure between Terminal #2 and 4).

DeviceNet™

Description: Optional external board that is mounted to the door board inside the Metal Box Controller Module. External board comes with its own directions.

Floating Blank

Description: On a press brake, the Floating Blank permits the work piece to be placed in the guarded area and can be moved around as long as it does not exceed the object sensitivity selected. A keyswitch by default allows for zero, one, two, or three beams to be blocked anywhere in the curtain as long as all the blocked beams are next to each other. The customer may request different blanking sizes for different applications. The Minimum Object Sensitivity (MOS) and the Depth Penetration Factor (DPF) change when the key switch position is changed. The DPF is used to compute the safety distance.

Location of the light curtain from the point of operation must include the depth penetration factor $D(pf)$ equivalent to the beam spacing.

Minimum Object Sensitivity indicates the minimum size required to cause the light curtain to detect an object even if it is moving (floating). If the obstruction is slightly smaller (less than .25") than the stated number, the light curtain may blink RED/GREEN when the object is moving in the field of view. If the obstruction is smaller than the stated number by at least .25", then the light curtain will stay GREEN as long as there are no additional obstructions.

Depth Penetration Factor is the number used to

Optional Features Metal Box Controller Module

compute the distance the light curtain should be placed from the point of operation (see *Installation Procedures*, "ANSI Standard B11.19-2010").

Diagnostics Display:

- RDY** Keyswitch is in the lowest position (Floating Blank is off).
- FB** Indicates Floating Blank active and the number of blocked beams.
- OBST** A second object found in the curtain (only one obstruction is allowed to float).

Table 1a: .5" Beam Spacing Pylons

Display	Minimum Object Sensitivity, S	D(pf) Depth Penetration Factor	Max. Floating object size less than
	Inches/Millimeters	Inches/Millimeters	Inches/Millimeters
RDY (float off)	0.55" / 14mm	0.935" / 23.8mm	0.00" / 0.0mm
FB1 (1 beam float)	1.18" / 30mm	3.077" / 78.2mm	0.45" / 11.4mm
FB2 (2 beam float)	1.75" / 45mm	5.015" / 129.2mm	0.95" / 24.1mm
FB3 (3 beam float)	2.36" / 60mm	7.089" / 180.2mm	1.45" / 36.8mm
FB4 (4 beam float)	2.95" / 75mm	9.095" / 231.2mm	1.95" / 49.5mm
FB5 (5 beam float)	3.54" / 90mm	11.101" / 282.2mm	2.45" / 62.2mm
FB6 (6 beam float)	4.13" / 105mm	13.107" / 333.2mm	2.95" / 74.9mm

Table 1b: 1" Beam Spacing Pylons

Display	Minimum Object Sensitivity, S	D(pf) Depth Penetration Factor	Max. Floating object size less than
	Inches/Millimeters	Inches/Millimeters	Inches/Millimeters
Rdy (float off)	1.18" / 30mm	3.077" / 78.2mm	0.00" / 0.0mm
FB1 (1 beam float)	2.36" / 60mm	7.089" / 180.2mm	0.95" / 24.1mm
FB2 (2 beam float)	3.54" / 90mm	11.101" / 282.2mm	1.95" / 49.5mm
FB3 (3 beam float)	4.72" / 120mm	15.113" / 384.2mm	2.95" / 74.9mm

⚠ WARNING Place Floating Blank keyswitch in lowest position and remove any obstructions while aligning light curtain. Do not use Floating Blank until light curtain is correctly aligned (see *Installation Procedure*, "Alignment Procedures"). The keyed selector switch is designated to be supervisory controlled. After installation, the safety key should be removed and controlled only by the safety supervisor or authorized plant personnel.

Guarding Mute-Out

Description: The Guarding Mute-Out option is the only fault-tolerant method of by-passing the light curtain during the nonhazardous portion of your machine cycle (i.e., up stroke of press).

Application: Allows any object to pass through the light curtain without opening the stop circuit and interrupting the machine cycle (i.e., the curtain stays GREEN).

Usage: The Guarding Mute-Out portion of the cycle occurs between the pinch point and top stop (about 180° to 300°) or any non-hazardous portion of your machine cycle.

You must power up the MicroGuard out of the Guarding Mute-Out condition, any other condition will cause an error to occur and you will have to power down the guard to reset it. When in Guarding Mute-Out, the MicroGuard will display "MUTE." If LS4 or LS5 limit switches are ever caught out of sequence, the guard will fault and issue an error message of "MUTE-OUT SWITCH FAULT" or "SLV MUTE-OUT SWITCH FAULT."

Use only the shielded cable provided! Do not route cable along with high voltage lines.

- 1) Connect one side of LS4 and LS5 to Terminal 4 inside MicroGuard.
- 2) Connect other side of LS4 to Terminal 1 inside MicroGuard.
- 4) Connect other side of LS5 to Terminal 3 inside MicroGuard.

Figure 2: Bottom Board Inside Control Box

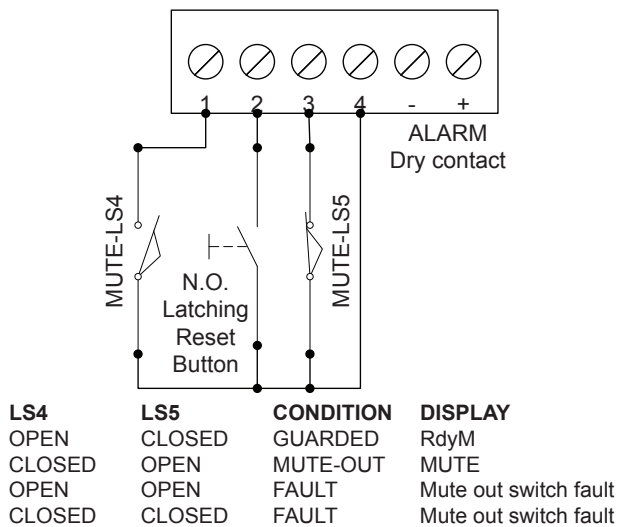

If both signals remain in the same state (i.e., both closed or both open) for more than 100mSec a fault will be issued.

NOTICE To by-pass this feature, jumper LS5 (terminal 3) to terminal 4.

To Activate Feature: This feature must be ordered and requires exchanging the computer chips (see *Controller Module Setup section for a diagram*).

Latching Relays

Description: Light curtain will stay in a RED condition when blocked, even when the blockage is removed and the guard is clear, until signalled to try and reset back to GREEN (unblocked).

If you have Auto-Blank, this option allows you to reset penetration without reprogramming the Auto-Blank.

Application: This is used for guarding an area against intrusion. Without this option the light curtain would only stay RED (safe) as long as the intrusion was detected (i.e., finger, hand, etc.).

Usage: Wire a N.O. button between Terminals 2 and 4. You can remote this button if you want. This feature must be ordered and requires exchanging the computer chips. Also, install jumpers on J15 and J17 on bottom 2 pins of each (bottom board).

CAUTION To turn off this option (for alignment purposes) short the 3 left pins of J4 together. Remove the shorted pins when done with the guard alignment.

SAFETY INSTRUCTIONS

⚠ WARNING The entire machine safety system must be tested at the start of every shift. Machine testing should include: (1) proper machine operation and stopping capability; and (2) verification of proper installation and settings of all point of operation guards and devices before the operation is released for production.

The MicroGuard should be mounted in a manner so that only authorized personnel can change the mounting or location.

Additional guards may be required to prevent the operator from standing between the light curtain and the point of operation.

Other infrared sources (i.e. other light curtains, etc) can interfere with operation and prevent the light curtain from properly aligning and giving a GREEN indication. Make sure that the RECEIVER pylon cannot view other infrared Emitters (except its own EMITTER pylon).

1) Test the unit before you mount it on your equipment by running the light curtain with the pylons butted up to and facing each other. Each cable and pylon is labeled "EMITTER" or "RECEIVER". You will feel a snap when the plug is fully seated and locked onto the connector. Attach a line cord to the power terminals for testing. If the light curtain goes GREEN, you are ready to proceed with the next step. If the light curtain stays RED, call your dealer for help in determining the problem.

2) Determine the Safety Distance of the light curtain from the point of operation (see *Installation Procedure*, "ANSI Standard B11.19-2010").

3) Determine if any part of the Microguard is to be directly subjected to either excessive shock and/or vibration. If so, mount the subjected parts to your equipment using shock-mounted devices (such as Part# 21-019). Shock and/or Vibration damage is not covered under warranty.

4) Mount both pylons with the connector side in the same direction mechanically aligned with one another. **Locate pylons so the working zone is guarded from reaching around, over, and under the light curtain system to the point of operation or hazard zone** (see *Installation Procedures*, "Safeguarding with Mechanical Guards").

Installation Procedures Metal Box Controller Module

NOTICE For location of pylons in relation to the hazard area, refer to *Appendix B: Regulations and Guidelines*, "Federal Register 1910.217 (c) (3) (iii) (e)."

4) Place the Controller Module in an accessible location where the cables can reach the pylons. Dress the cables to avoid crushing, kinking, or cutting (see *Dimensions*, "Controller Module").

5) Wire power to the proper terminals and check that the voltage is correct (see *Installation Procedures*, "Controller Module Setup").

Power for the MicroGuard should not be down stream of noisy inductive devices (i.e., motors, solenoids, etc.), it should be in front of them.

6) Interface the light curtain standard relay output contacts to the safety stop circuit(s). You must use both K1 and K2 output contacts. **Do not use an external relay(s) unless you use the external relay checking feature.**

7) Interface any remaining optional input or output lines to their proper terminals (see *Optional Features*).

8) Align the light curtain (see *Installation Procedures*, "Alignment Procedure").

9) Use a round test piece (i.e., dowel rod) that has a diameter equal to the minimum object sensitivity. Check and assure stop of machine when signal of penetration is made. Minimum object sensitivity goes up if you use Auto or Floating Blank options.

10) Mechanical guarding may also be required from reaching around the light curtain to the point of operation (see *Installation Procedures*, "Safeguarding with Mechanical Guards").

11) For installation assistance, please call your dealer.

NOTICE For location of pylons in relation to the hazard area, see *Appendix B: Regulations and Guidelines*, "Federal Register 1910.217 (c) (3) (iii) (e)" and *Installation Procedures*, "Safeguarding with Mechanical Guards".

Resetting the MicroGuard

Error messages are stored in a nonvolatile memory (EEPROM). To clear error messages, press the RESET button. **DO NOT hold in the button or hit it twice, just one hit.** The unit will not reset until it is finished displaying the entire error message.

If you remove power from the unit without clearing the error message, the message will reappear when you power back up. Hit the RESET button to clear this error from memory.

The RESET button is located inside the MicroGuard Controller Module on the door circuit board, left hand side, or the lower circuit board underneath the gray ribbon cable to start up the light curtain.

You can review all previous error messages recorded by holding down the RESET button while turning on the power to the unit, for two seconds. Each error message will scroll by, last error first. When you see the message "NO MORE CODES," hit the RESET button to start up the curtain. Up to 45 previous error messages can be displayed. You can shut down the curtain during normal operation by pressing the RESET button.

SAFETY INSTRUCTIONS

Alignment Procedure

- 1) Both pylons should be placed so that they are mechanically aligned to one another. Make sure that both ends of each pylon line up with each other.
- 2) Slightly loosen the mounting bracket screws to allow for slight rotational movement of Receiver pylon.
- 3) Move the Receiver pylon to find its midpoint (or sweet spot) where the unit goes from RED to GREEN to RED.
- 4) Tighten the screws once you find the midpoint and repeat the operation for the Emitter pylon.

If you still cannot get the unit to go GREEN

- 5) Recheck mechanical alignment.
- 6) The diagnostics display will indicate the distance (in inches) of the first missing beam from the connector end of the guard and the total number of missing beams (i.e., 12 4 = first missing beam is 12" from connector and a total of 4 beams are missing or 015A = first missing beam is 1.5" from connector and 10 beams are missing)

Installation Procedures

Metal Box Controller Module

- 7) Loosen the mounting bracket corresponding to the end of the pylon closest to the missing beam and adjust it to get the unit to go GREEN.

If you are using mirrors, refer to Figure 3

- 8) Every mirror you use will increase the difficulty of alignment and will reduce the overall maximum optical distance you can achieve. A loss of 5% per mirror should be used to determine the total optical distance (i.e., 15' through two mirrors = 16.5' with losses).
- 9) You may have to rotate all mirrors in turn (starting from the Emitter end) to find the true optical path of infrared light. Also, you may have to toe in one end of the mirror due to irregularities in the mirror brackets.

NOTICE

Make sure you do not exceed the total optical path distance of 20' or the curtain distance that was specified.

Figure 3: 4 Sided Guarding with Dual Stud Guard Brackets, TRM Mirrors and Model #8000 Pedestals

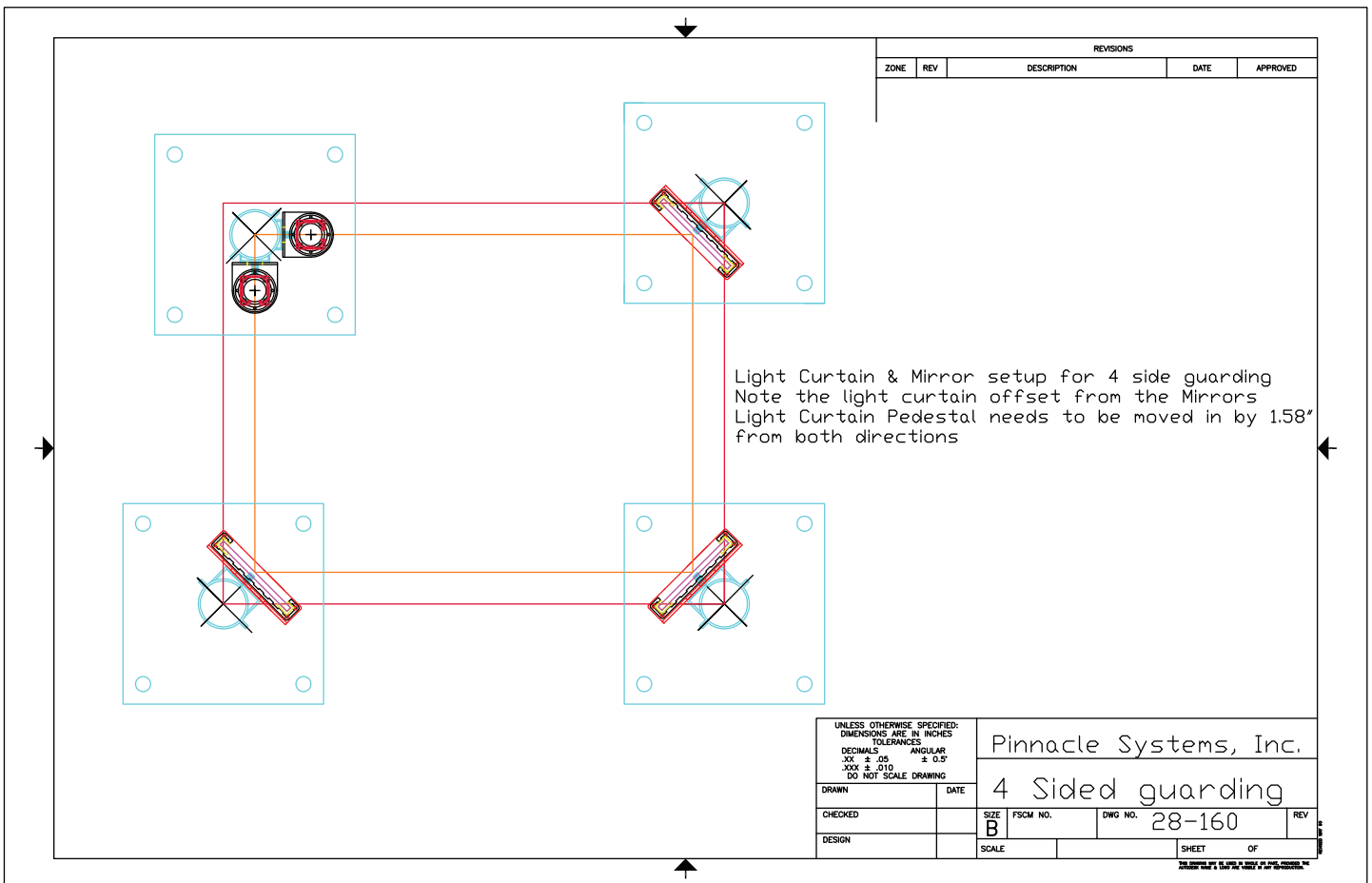

Operations

⚠ CAUTION

Examine the MicroGuard on a daily basis to make sure that no one has moved the light curtain pylons closer to the pinch point or removed any mechanical guards from around the curtain.

If it is possible for someone to go through the light curtain and remain in a dangerous area without having to block the light curtain, you must order the Resettable Latching Relays option which keeps the curtain RED even after you are no longer blocking the curtain. The Latchout reset button is mounted away from the dangerous area and must be cycled to reset the curtain.

- 1) Power up the light curtain. If a fault occurred the last time the unit was powered and was never RESET, it will appear as a "SLAVE FOUND" error message and you will have to push the RESET button to clear the fault message and start the curtain.
- 2) When GREEN the curtain will display "RDY" or "rdy" depending on any options that were set (see *Appendix A: Diagnostics and Troubleshooting for Descriptions*).
- 3) When RED due to blockage, the display will indicate the location of the first obstruction(s) and the total size of the obstruction(s) (see *Appendix A: Diagnostics and Troubleshooting*). If you have Floating Blank, then this is indicating that your object is too large for the floating size you have selected. If you increase the Floating Blank size, you must recalculate the safety distance formula since the object sensitivity will be larger. If you have the Resettable Latchout option, the display will show "PENT" to indicate penetration. You must cycle the Latchout RESET button to clear the curtain (see *Optional Features, "Resettable Latching Relays"*).
- 4) When RED due to a fault, the display will scroll the error message that caused the fault and the board and beam number (if it can be pin pointed). You must first correct the fault and then push the RESET button to clear the fault from memory, even powering down the unit will not clear the fault from memory (see *Appendix A: Diagnostics and Troubleshooting*).
- 5) If you have the Guarding Mute-Out option, the display will show "MUTE" during the up stroke. If you have the Cincinnati Interface hooked up, the display will show "CINN" during the up stroke (see *Optional Features, "Guarding Mute-Out"*).

6) **Auto Blank.** The display will show "AB" to indicate that an object is programmed in and its size (in beams) is shown as the next digit. If you keep getting a "MOVE" message and your object is not moving, try repositioning the object slightly (+/- 1/4") and reprogram it back into memory. If you get a "SIZE" message, you must either get new software to allow a larger object or reduce your object size.

7) **Floating Blank.** The display will show "FB" to indicate the allowed blanking size in beams. Once an object penetrates the curtain, any second object will cause the curtain to display "OBST" to indicate that a second obstruction is in the curtain. This is done in case you select a Floating Blank size much larger than the actual object size.

ANSI Standard B11.19-2010

Formula for calculating safety distance of light curtains from hazardous point of operation.

The effective sensing field of the device shall be located at a distance from the nearest recognized hazards such that the operator or others cannot reach the hazard with a hand or other body part before cessation of motion during the hazardous portion of the machine cycle.

The point at which a device responds to an intrusion may vary. The devices should be located or adjusted such that the device always responds to the intrusion at or prior to the safety distance. Care should be exercised when installing the device to ensure that it does not detect false signals from other devices in the area.

Usually the electro-optical presence-sensing device is used in a manner that provides a protected zone in front of the primary work area with auxiliary devices or guards used to protect secondary access areas. In some cases, however, mirrors may be used in conjunction with the device to provide 2-, 3-, or 4-sided protection.

The machine stop time should be measured with the machine running at its fastest speed with its heaviest die or tooling and the stop time being measured at the 90° position in the downstroke.

The following formula should be used when calculating the safety distance:

- $D_s = K \times (T_s + T_c + T_r + T_{bm}) + D(pf)$
- D_s = Minimum safety distance between the device and the nearest point of operation hazard (in inches).
- K = Hand speed constant. This value has been determined by various studies and, although these studies indicate speeds of 63 in/sec to over 100 in/sec, they are not conclusive determinations. The employer should determine this value by considering all factors, including physical ability of the operator.
- T_s = Stop time of the machine tool measured by a stop time measurement device.
- T_c = Response time of the control system (usually is taken care of by the measurement device).
- T_r = Response time of the presence-sending device and it's interface, if any, as stated by the manufacturer or measured by the employer.
- T_{bm} = Additional time allowed for the brake monitor to compensate for variations in normal stopping time.
- $D(pf)$ = Depth Penetration Factor. Added distance as indicated by Figure 4 on this page. The minimum object sensitivity is stated by the manufacturer. If a Floating Blank is used, use the Dpf numbers found in the Floating Blank section of this manual.

Figure 4: Minimum Object Sensitivity and D(pf)

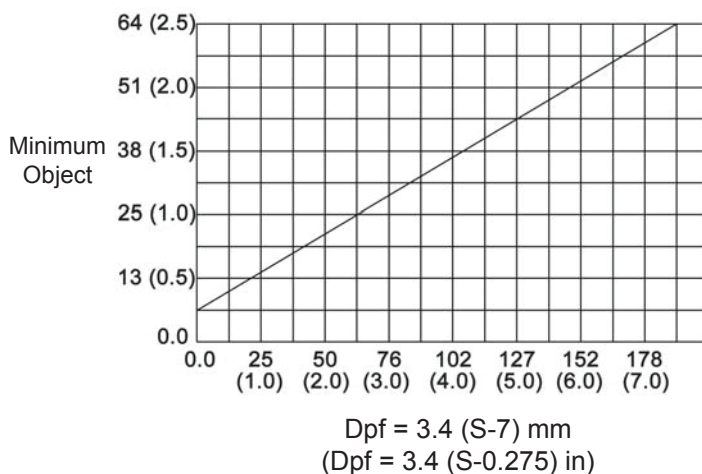

Penetration factor, Dpf, for presence-sensing devices used in a vertical application with object sensitivity less than 64 mm (2.5 inches)

Dpf, the distance added to the safety distance due to the penetration factor compensates for varying object sensitivities of electro-optical presence-sensing devices.

When blanking features are used and when the blanked area is not completely filled by the workpiece or part, or by mechanical guarding, the minimum object sensitivity can be calculated as:

Object sensitivity = size of the blanked area plus minimum object sensitivity without blanking.

Once this value is found, then determine Dpf.

If the entire blanked area is filled with mechanical guarding or other fixed material or guards, use the device's object sensitivity to determine Dpf.

Safeguarding with Mechanical Guards

When a light system is used to protect the operator or passerby from penetration, it must be mounted and properly sized (grid length) so it is impossible to reach under, around, or over into the hazardous point of operation zone. Infrared light systems normally guard the front or feed area of a machine. The sides or the areas where the light screen does not guard must be guarded by some other means.

If the position of the safety light curtain will allow the operator or others to place themselves between the sensing field and the hazardous area, auxiliary guards or devices such as safety mats, barrier guards, or devices should be used in conjunction with the safety light curtain to prevent the operator or others from exposure to the hazardous area. If mechanical guards such as polyurethane, expanded or perforated metal, hairpins, etc. are used to guard these areas, the opening must comply with the OSHA safety distance in relationship to the openings.

After installation of point of operation guards and before a job is released for operation, a check should be made to verify that the guard will prevent the operators hands from reaching into the point of operation or any hazard zone.

Table 2 outlines the distances that guards should be positioned from the nearest point-of-operation hazards.

The various openings are such that for average-sized hands, an operator's fingers will not reach the point of operation.

After installation of point-of-operation guards and before a job is released for operation, a check should be made to verify that the guard will prevent the operator's hands or other body parts from reaching the point of operation.

Light Curtain Test Procedure

Use a dowel rod (or similar object) with a diameter equal to the M.O.S. (Minimum Object Sensitivity) of the guard you are testing. Move the rod through the field of the curtain (i.e. top to bottom for vertically mounted curtains). Repeat this test close to the Emitter pylon, close to the Receiver pylon, in the middle between the pylons, and most importantly in front of the operator position.

Make sure the curtain indicates a "Blocked" condition (RED light) when the rod is in the field of the curtain. Check and make sure the machine cannot move when the curtain shows "Blocked". If the machine can operate while the curtain shows a "Blocked" condition, then re-examine your wiring.

If the curtain does not show "Blocked" when the rod is in the field: Check to make sure the rod is truly in the curtain's field, and re-check the curtain's Minimum Object Sensitivity (including AutoBlank and Floating blank options that change the M.O.S.).

Infrared light from the curtain may be reflecting around the rod due to reflective material too close to the curtain's field. In this case, you will have to move the curtain pylons back away from the reflective material and repeat the test over again. The curtain's power level can also be reduced by the factory.

Table 2: Mechanical Guards

Distance of opening from point of operation hazard (inches)		Maximum width of opening (inches)
1/2	to 1-1/2	1/4
1-1/2	to 2-1/2	3/8
2-1/2	to 3-1/2	1/2
3-1/2	to 5-1/2	5/8
5-1/2	to 6-1/2	3/4
6-1/2	to 7-1/2	7/8
7-1/2	to 12-1/2	1-1/4
12-1/2	to 15-1/2	1-1/2
15-1/2	to 17-1/2	1-7/8
17-1/2	to 31-1/2	2-1/8

SAFETY INSTRUCTIONS

Installation Procedures Metal Box Controller Module

Controller Module Setup

Table 3: Controller Module Connection Chart (Lower Board)

1	Mute-Out Input LS4 (optional)	10	Aux relay K3 (common)
2	Remote Latch reset input	11	Aux relay K3 (N.C.) close when Red
3	Mute-Out LS5 (optional)	12-13	Safety Output #1 N.O. close when Green
4	Ground for Terminals	14-15	Safety Output #2 N.O. close when Green
5	Cincinnati Interface + Input	16	Case Ground (Earth)
6	Cincinnati Interface – Input	17-18	Neutral (-) and Line (+)
7	External relay monitor input	alarm	Dry relay opens on fault or loss of power
8	External relay monitor input		
9	Aux relay K3 (N.O.) close when Green		

Figure 5: Controller Module (Lower Board)

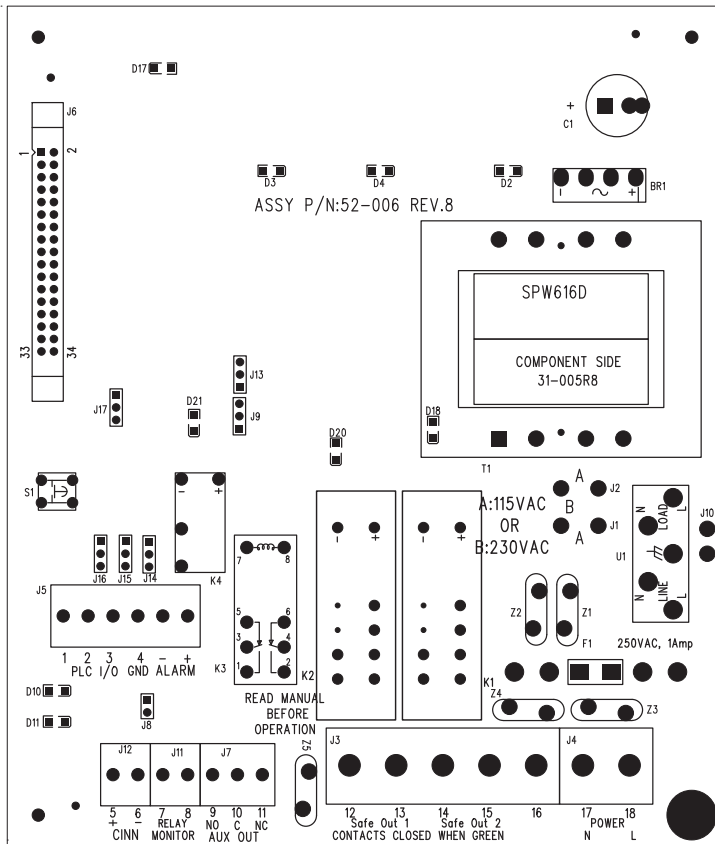

CAUTION

Current Boards (Rev 8 and newer):

K1, K2 use only Safety Relays PN# 32-101.

Machinery with a **single STOP** circuit:

Wire STOP circuit into Terminal #12, and out Terminal #13

Machinery with **dual STOP** circuits:

Wire STOP circuit #1 into Terminal #12, and out of Terminal #13.

Wire STOP circuit #2 into Terminal #14, and out of Terminal #15.

CAUTION

Older Boards (Rev 7 and older):

K1, K2 use only Safety Relays PN# 32-001

Machinery with a **single STOP** circuit:

Wire STOP circuit into Terminal #12, and out Terminal #15.

Install a jumper wire between Terminals #13 & #14

If there is no #13 or #14 Terminals, the jumper is under the PCB already

Machinery with **dual STOP** circuits:

Wire STOP circuit #1 into Terminal #12, and out of Terminal #13.

Wire STOP circuit #2 into Terminal #14, and out of Terminal #15.

If there is no #13 or #14 Terminals, you must call the factory to get Terminals, and cut the jumper under the PCB.

CAUTION

All Board Versions:

K3 use only Relay PN# 32-001 for auxiliary purposes only

K4 use only Relay PN# 32-002 for Fault signal only (alarm terminals)

Table 4: Single Pylon Set Controller Module Jumper Chart

Auto Blank / Floating Blank Keyswitch..... J4
 Pylon Length Selector..... S3

1 = Jumper

	4"	8"	12"	16"	20"	24"	28"	32"	36"	40"	44"	48"	52"	56"	60"	64"
D0	1		1		1		1		1		1		1		1	
D1	1	1			1	1			1	1			1	1		
D2	1	1	1	1					1	1	1	1				
D3	1	1	1	1	1	1	1	1								
D4	1	1	1	1	1	1	1	1	1	1	1	1	1	1	1	1

	68"	72"	76"	80"	84"	88"	92"	96"	100"	104"	108"	112"	116"	120"
D0	1		1		1		1		1		1		1	
D1	1	1			1	1			1	1			1	1
D2	1	1	1	1					1	1	1	1		
D3	1	1	1	1	1	1	1	1						
D4														

For pylons with 1" beam spacing, install the Jumper plug (just below D4)

For pylons with 1/2" beam spacing, remove the Jumper plug (just below D4)

EXT (Activates External Relay Check, *see Standard Features*)..... J9
 FLASH (Doubles response time of light curtain allow for Arc Weld Flash near light curtain..... J9
 LATCH (Activates remote latch resetting (*see Resettable Latching Relays*) J9
 FAULT RESET BUTTON (Push button to reset faults, do not hold button in)..... S2

Figure 6: Controller Module Jumper — Upper Board

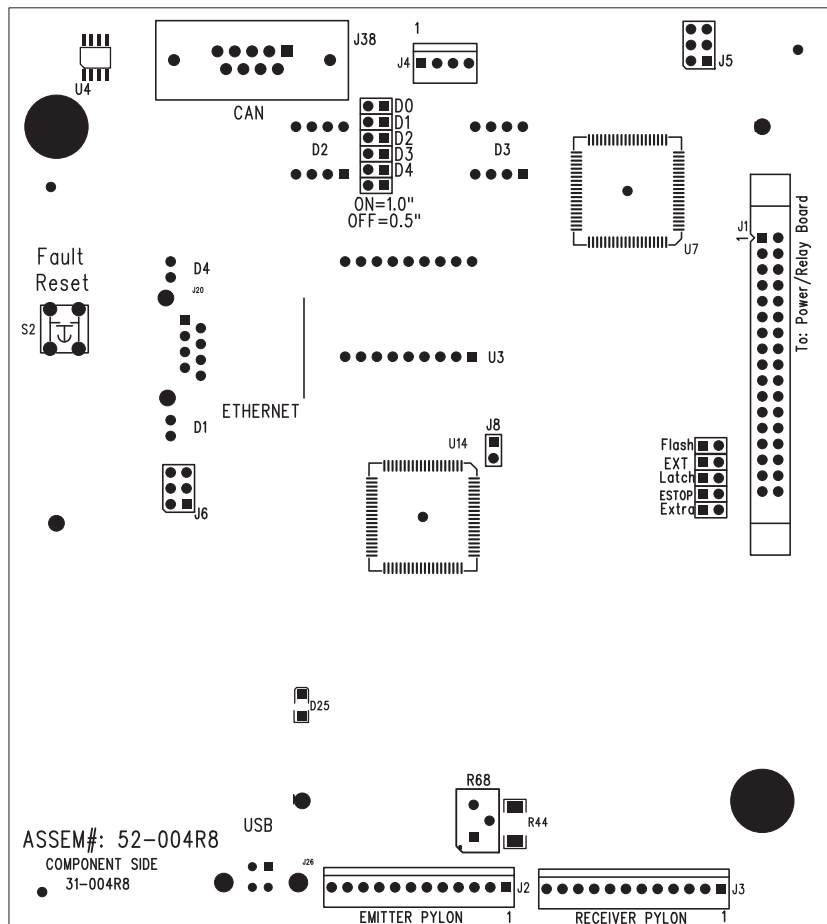

Table 5: Multiple Pylon Set Controller (DUAL - SC) Module Length Jumper Chart

Auto Blank / Floating Blank Keyswitch..... J40

Pylon Length Selector..... S3 & S4

1 = Jumper

	4"	8"	12"	16"	20"	24"	28"	32"	36"	40"	44"	48"	52"	56"	60"	64"
D0/L0	1		1		1		1		1		1		1		1	
D1/L1	1	1			1	1			1	1			1	1		
D2/L2	1	1	1	1					1	1	1	1				
D3/L3	1	1	1	1	1	1	1	1								
D4/L4	1	1	1	1	1	1	1	1	1	1	1	1	1	1	1	1

	68"	72"	76"	80"	84"	88"	92"	96"	100"	104"	108"	112"	116"	120"
D0/L0	1		1		1		1		1		1		1	
D1/L1	1	1			1	1			1	1			1	1
D2/L2	1	1	1	1					1	1	1	1		
D3/L3	1	1	1	1	1	1	1	1						
D4/L4														

For pylons with 1" beam spacing, install the Jumper plug (just Left of D4/L4)

For pylons with 1/2" beam spacing, remove the Jumper plug (just Left of D4/L4)

EXT (Activates External Relay Check, *see Standard Features*)..... J9

FLASH (Doubles response time of light curtain allow for Arc Weld Flash near light curtain..... J9

LATCH (Activates remote latch resetting (*see Resettable Latching Relays*) J9

FAULT RESET BUTTON (Push button to reset faults, do not hold button in)..... S2

Figure 7: Multiple Pylon Controller Module Connector/Jumper Detail

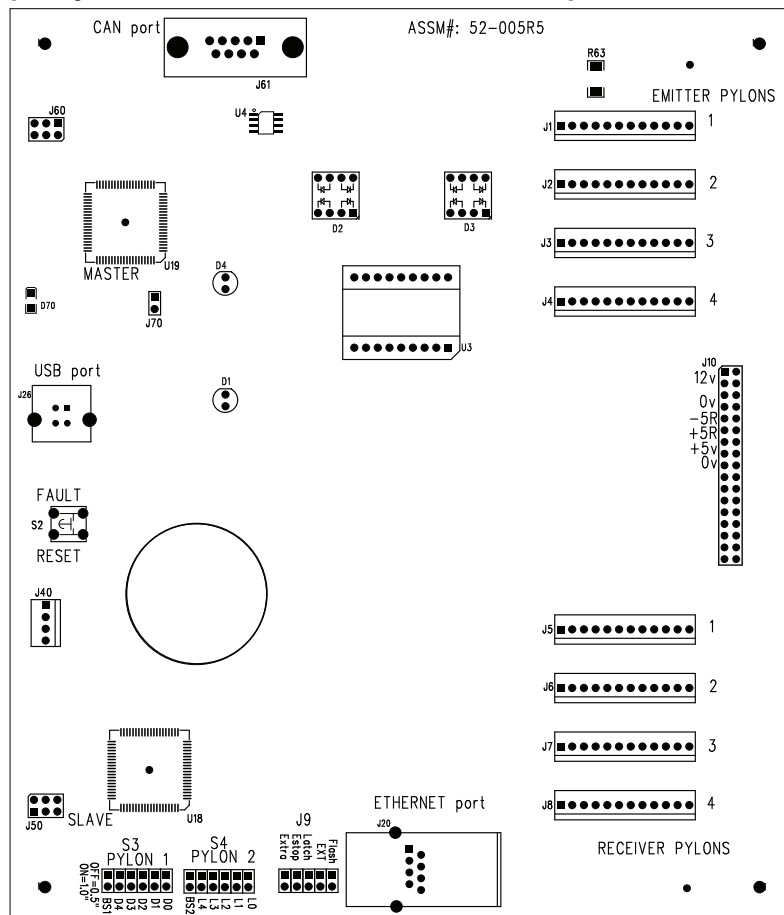

Wiring

Figure 8: Controller Module Wiring Diagram

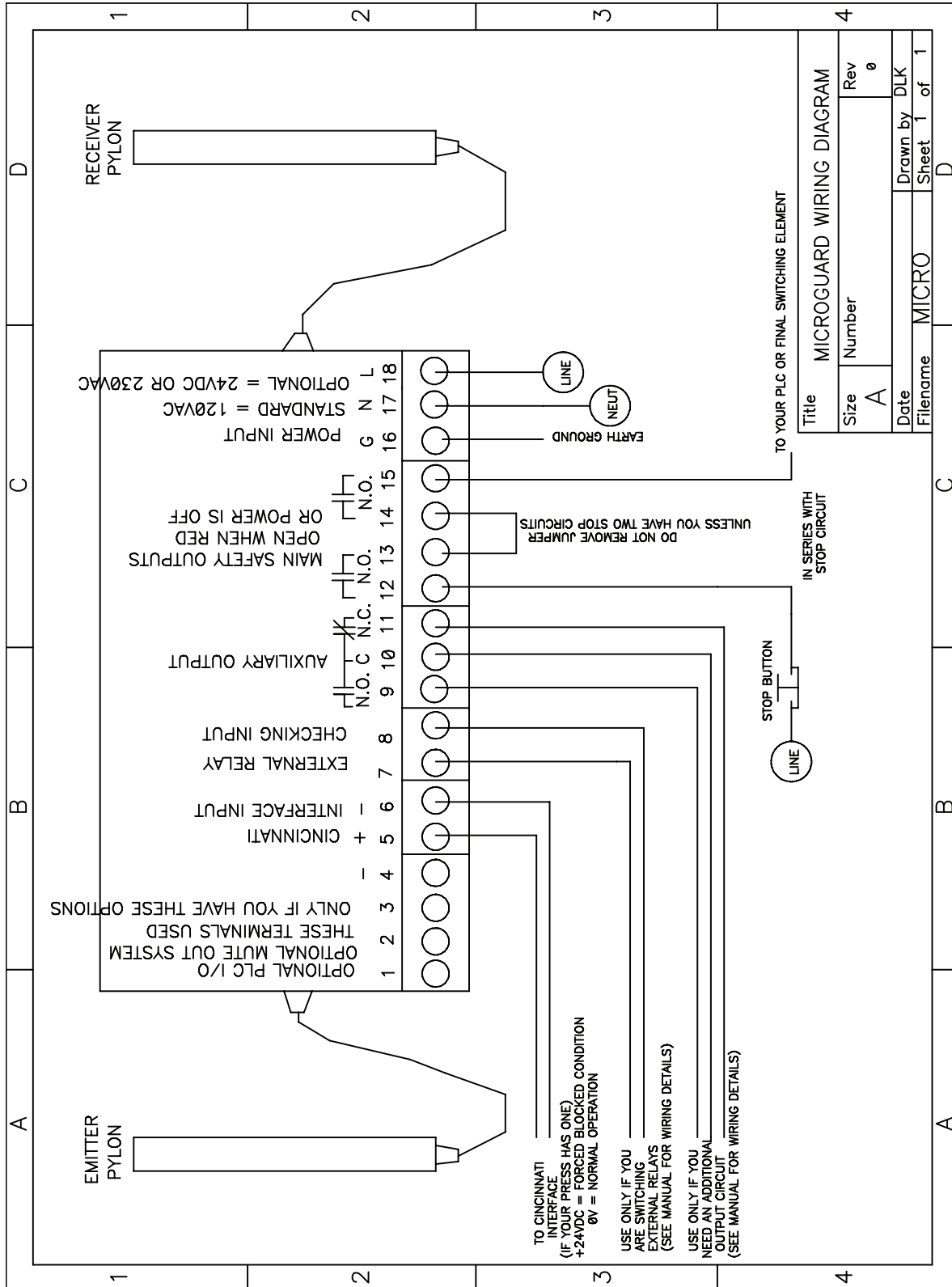

Pylon Dimensions

Figure 9a: Swivel Bracket Dimensions

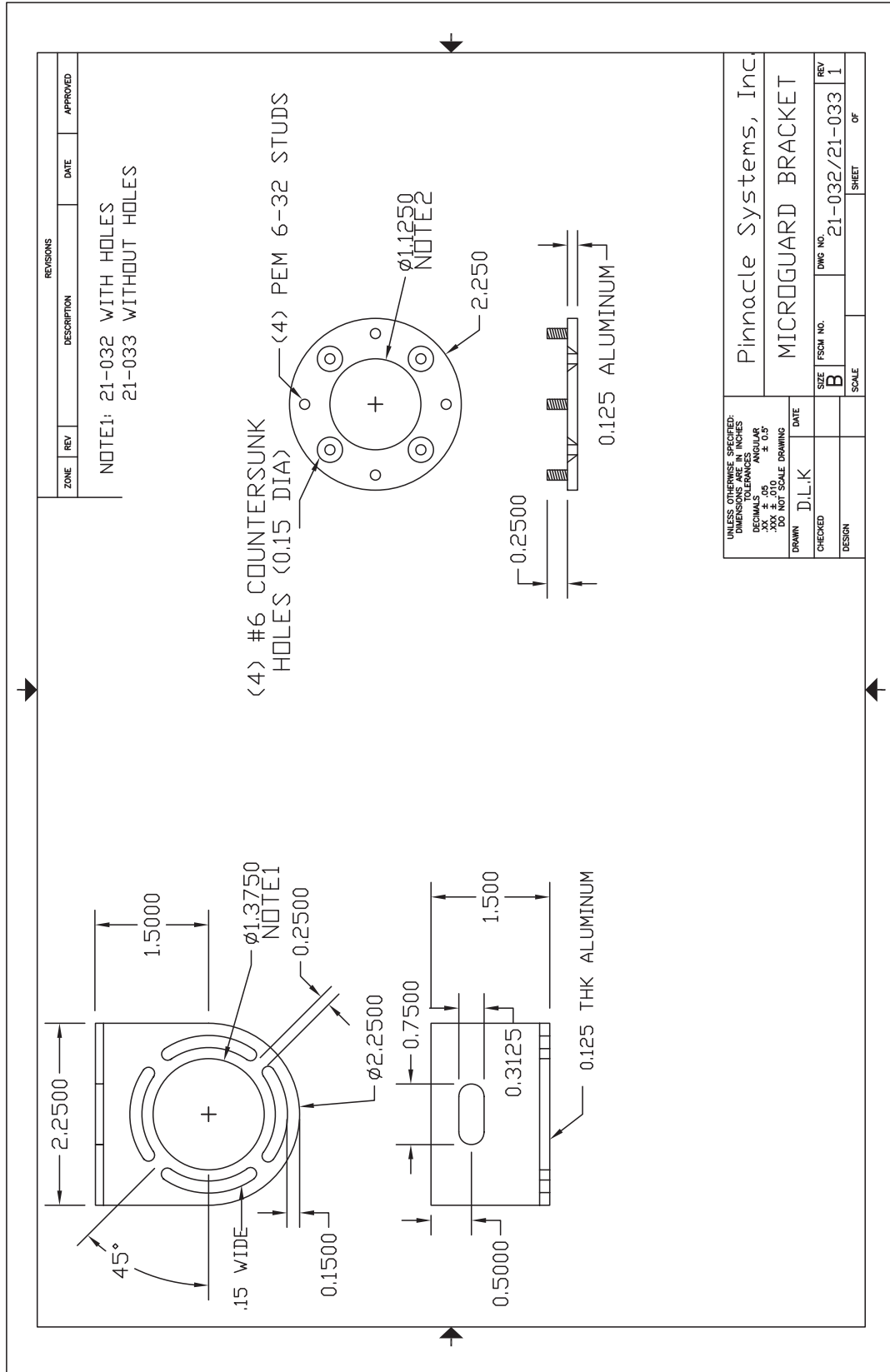

Dimensions

Metal Box Controller Module

Pylon Dimensions

Figure 9b: Swivel Bracket Dimensions, pylon dimensions (by model), and additional cable information

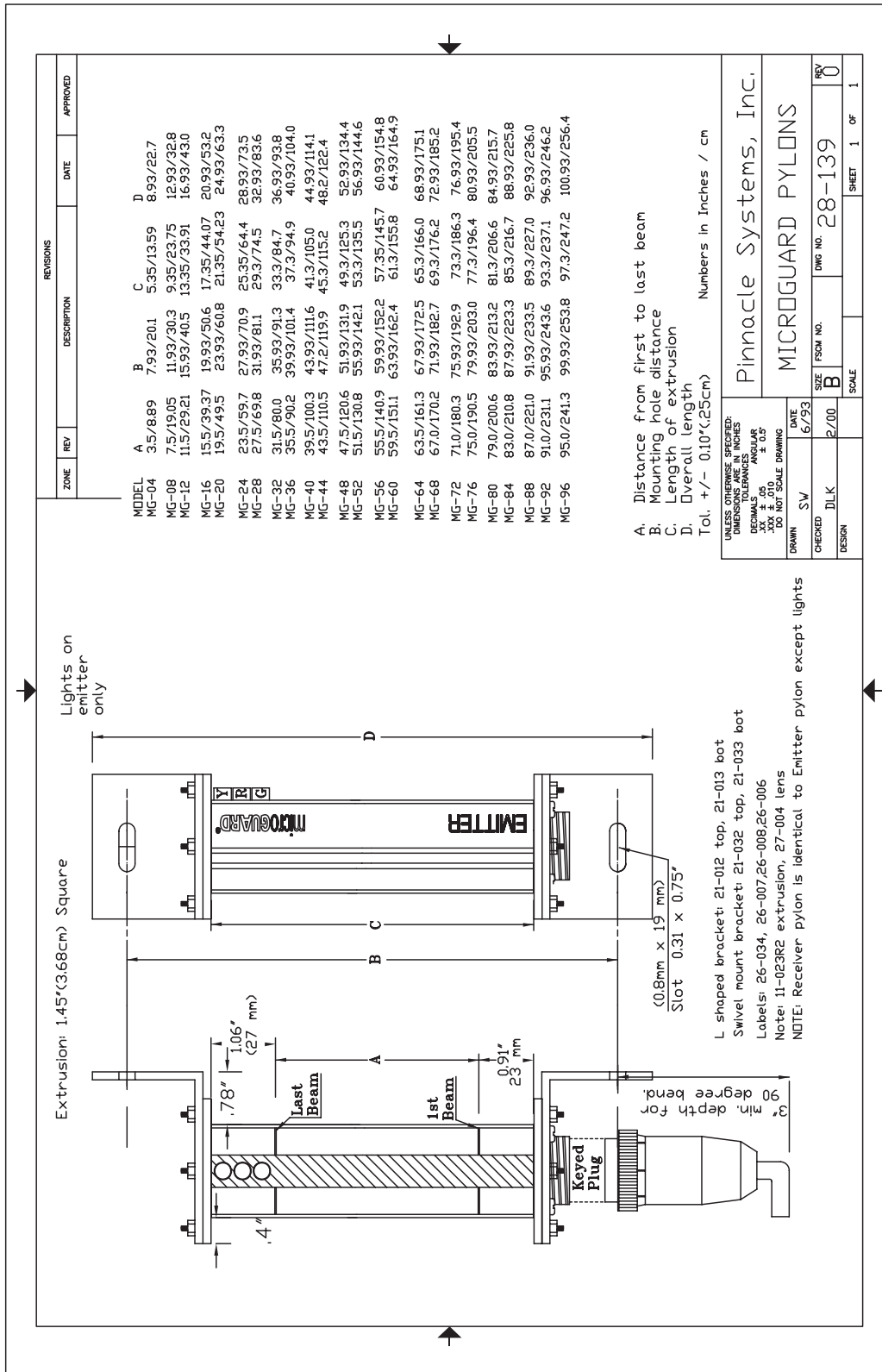

Pylon Dimensions

Figure 10: Fixed Bracket Dimensions, pylon dimensions (by model), and additional cable information

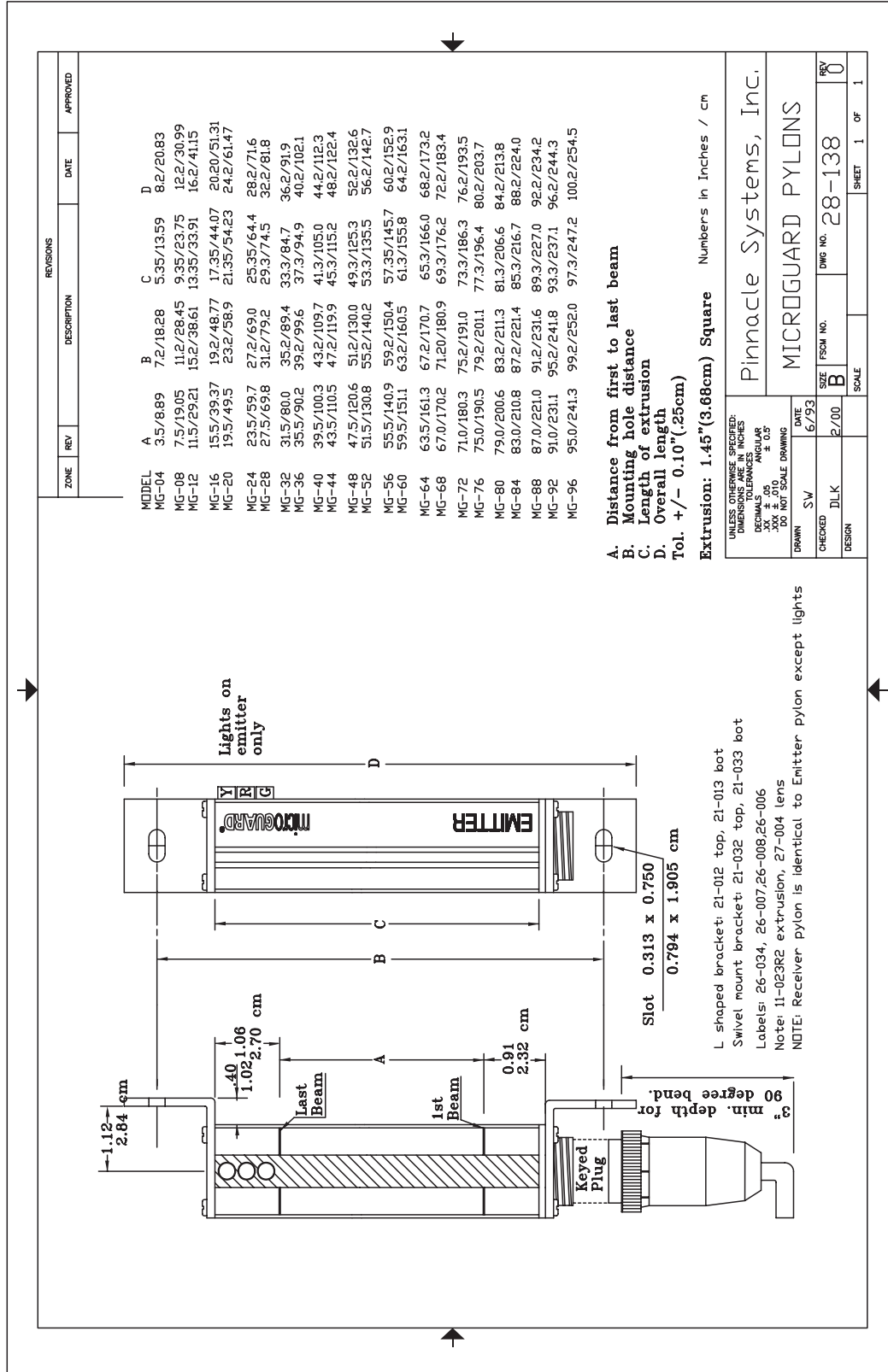

Dimensions

Metal Box Controller Module

Controller Module

The Emitter cable plugs into a bulkhead connector on the bottom right of the controller. The Receiver cable plugs into a bulkhead connector on the bottom middle of the controller. All other signals, including power, enter through the knockout provided on the bottom left of the controller. The bulkhead connectors are water/dust/oil tight. Cables lock onto the bulkhead connectors with a 1/4 turn.

Tol. +/- 0.10" / 2.54mm

Figure 11: Controller Module Dimensions

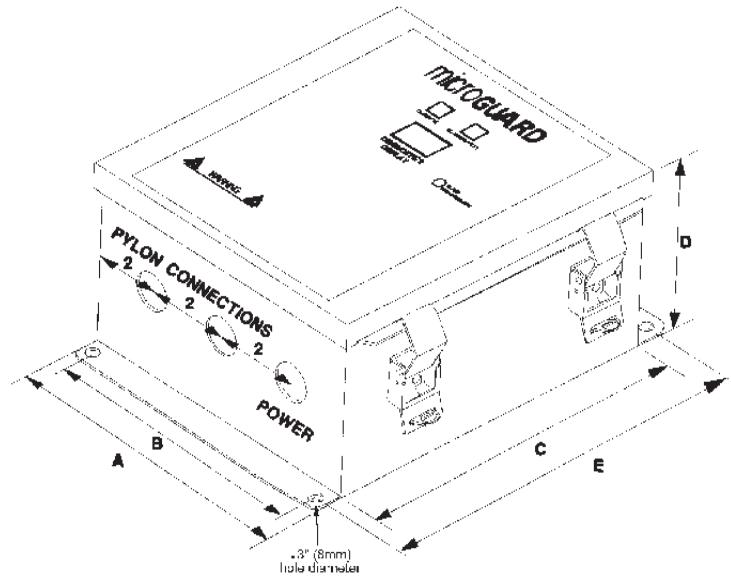

Table 6: Controller Module Dimensions

Dim	Single (in/mm)	Multiple (in/mm)
A	7" / 177.8	8" / 203.2
B	4" / 101.6	7" / 177.8
C	8" / 203.2	9" / 228.6
D	4" / 101.6	4" / 101.6
E	8.65" / 215.9	9.85" / 248.9

Cornering Mirrors

Through the use of cornering mirrors, multiple sides or work envelopes can be guarded which enhance safety and down-time related to mechanical and electrical interlock systems. Be sure to include a reflectivity loss per mirror (15% for MGM, 10% for TRM) when calculating total scanning distance of light curtain.

NOTICE

Mirrors are surface coated. Wipe surface using only a damp, clean, soft 100% cotton cloth. To replace broken or scratched glass, remove end bracket and slide mirror out with gasket.

WARNING

If you are using Auto Blank or Floating Blank options, you may unknowingly create a hole around your machine. Do not use mirrors with blanking unless you need blanking on all guarded sides.

Table 7: Cornering Mirror Dimensions

MODEL	DIM A (in/mm) (hole to hole distance)	DIM B (in/mm) (mirror length)	DIM C (in/mm) (total length)
TRM-04 / MGM-04	7.45 / 189	6.25 / 159	8.50 / 216
TRM-08 / MGM-08	11.45 / 240	10.25 / 260	12.50 / 318
TRM-12 / MGM-12	15.45 / 392	14.25 / 362	16.50 / 419
TRM-16 / MGM-16	19.45 / 494	18.25 / 464	20.50 / 521
TRM-20 / MGM-20	23.45 / 595	22.25 / 565	24.50 / 622
TRM-24 / MGM-24	27.45 / 697	26.25 / 667	28.50 / 724
TRM-28 / MGM-28	31.45 / 799	30.25 / 768	32.50 / 826
TRM-32 / MGM-32	35.45 / 900	34.25 / 870	36.60 / 927
TRM-36 / MGM-36	39.45 / 1002	38.25 / 971	40.50 / 1029
TRM-40 / MGM-40	43.45 / 1104	42.24 / 1073	44.50 / 1130
TRM-44 / MGM-44	47.45 / 1208	46.25 / 1175	48.50 / 1232
TRM-48 / MGM-48	51.45 / 1307	50.25 / 1276	52.50 / 1334
TRM-52 / MGM-52	55.45 / 1408	54.25 / 1378	56.50 / 1435
TRM-56 / MGM-56	59.45 / 1510	58.25 / 1480	60.50 / 1537
TRM-60 / MGM-60	63.45 / 1612	62.25 / 1581	64.50 / 1638
TRM-64 / MGM-64	67.45 / 1713	66.25 / 1683	68.50 / 1740

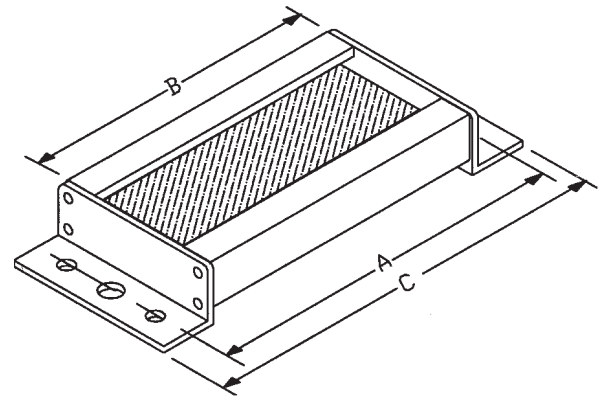

Tolerance: +/- 0.10 inches / .025cm

Figure 12: Cornering Mirror Dimensions

MGM Dimensions

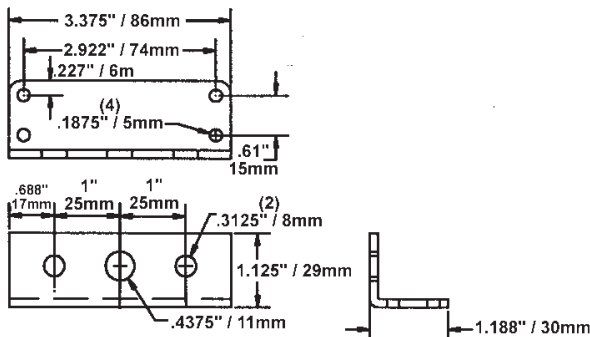

TRM Dimensions

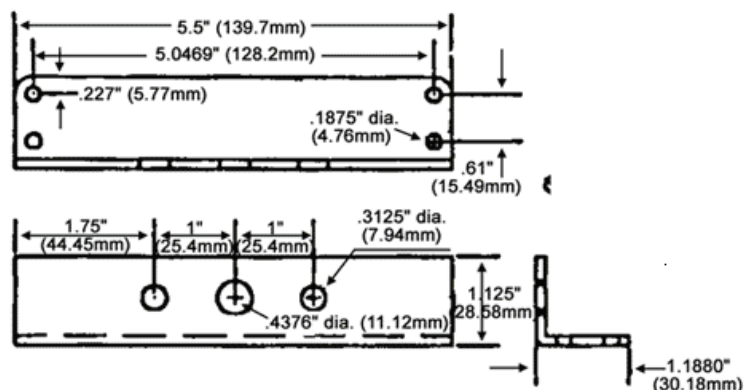

Accessories

Metal Box Controller Module

Pedestal

The heavy duty, all-welded steel pedestal floor mounts can be used for mounting either the MicroGuard Metal Box or DIN-rail Controller Module light curtain or cornering mirrors. Sliding mounts on the pedestal are universal in design and are supplied standard. Unique floating base on pedestal is designed to compensate for uneven floors. Pedestal is fabricated from 12 gauge steel, the base is 1/4" steel plate, and the entire unit is painted OSHA yellow.

Standard height = 72" (model 8000)

Optional height = 96" (model 8096)

NOTICE Do not mount pedestal to floor until you have fully installed your guarding system and know it is operating properly in its current position on the floor.

CAUTION Pedestals must be bolted to the floor after installation; they must not be movable.

- 11-183 Standard Single mounting bracket (shown)
- 11-184 Special Dual pedestal mounting bracket. Has two mounting studs 90 deg apart. Allows both Emitter and Receiver pylon on one pedestal. Requires SMB option on pylons.

Model 9000 and 9500

Excellent method of mounting the light guard for press brakes or when the light guard is to be moved for die setups or machine maintenance. Model 9000 consists of three 180-pivot points along with light guard diagonal movement capability for virtually unlimited light guard positioning. Two-inch square tubing 3/16" thick painted OSHA yellow which mounts directly onto the machine housing and makes for a heavy duty yet versatile mounting bracket. Model 9500 consists of two 180-pivot points and one adjustable length arm.

Model 9000 Swing Arm Brackets

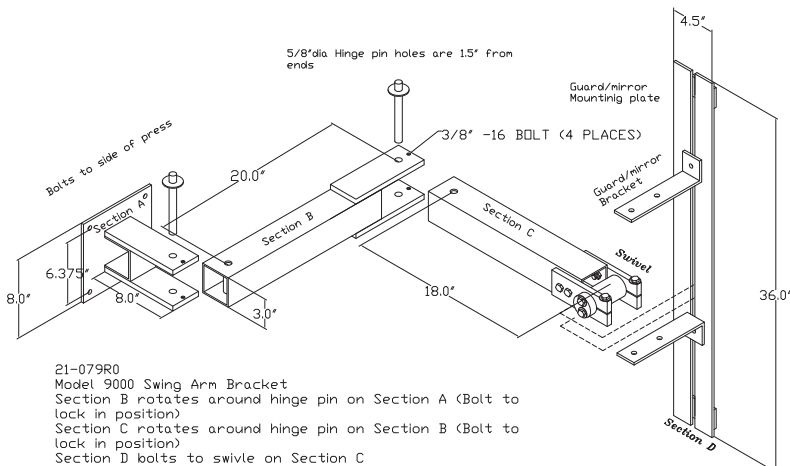

Figure 13: Pedestal Dimensions

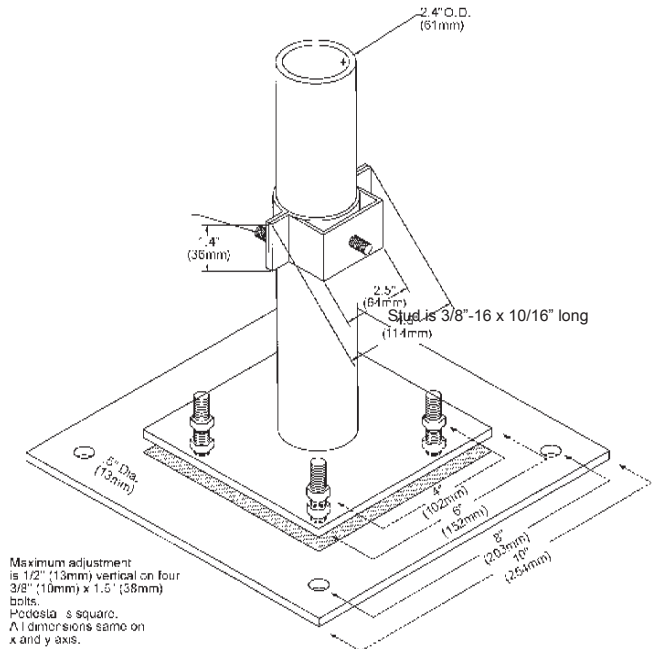
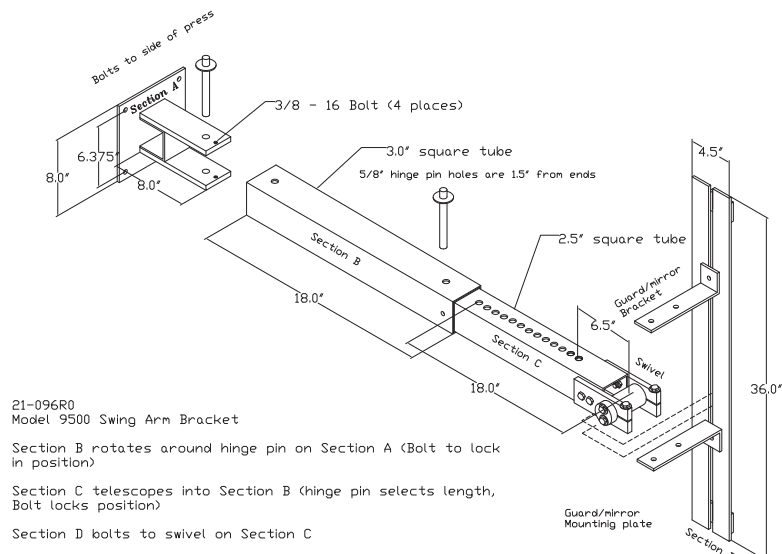

Figure 14: Swing-Arm Mounting Bracket Dimensions

Model 9500 Swing Arm Brackets



NOTE: For all guards with a USB connector on the inside of the door (after 6/2012)

Obstruction or Misalignment

When the curtain is obstructed or misaligned, the display will present four numbers to indicate location of obstruction or misalignment. Not a scrolling message.

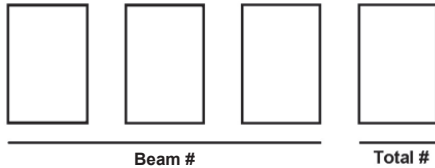

Beam # (Distance)

The first three numbers displayed represent the beam # of the first obstructed or misaligned beam. Beam #1 is located at the cable end of the pylon and counts up. If you have a 1/2" beam spacing (-0F), the number increment every 1/2". If you have 1" beam spacing (-0F1), the number increments every 1". If you have 4" beam spacing (-0F4), the number increments by 1" for the first 4 beams, then jumps a 4" gap, then increments by 1" for the next 4 beams, then another gap, etc., etc.

Note: If you have multiple pylons to one control box (-SC), the cable end of the 2nd pylon is the next beam# after the 1st pylon, etc. etc.

Note: If you tap the Reset button (inside of the door), the Display will increment to show you the next blocked beam

Note: You can also use the USB port to read the obstruction locations (see appendix D)

Total

The last digit indicates the total number of beams blocked or misaligned. The digit counts in Hexadecimal (0 to F = 0 to 15 beams). A ">" sign indicates more than 15 beams missing.

"A"=10 beams, "B"=11 beams, "C"=12 beams, "D"=13 beams, "E"=14 beams, "F"=15 beams

Examples:

604 = The 60th beam is blocked along with 3 more beams

10A= The 10th beam is blocked along with 9 more beams

Error Conditions

When a scrolling ERROR message is displayed, the end of the message will display a set of numbers to indicate where along the pylon the problem resides.

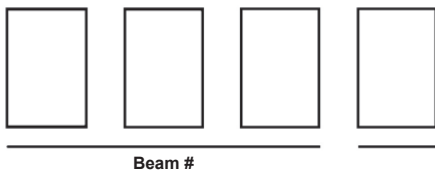

Beam # (Distance)

As defined above under "Obstruction or Misalignment."

NOTE: For all guards with socket microprocessors (prior to 6/2012)

Obstruction or Misalignment

When the curtain is obstructed or misaligned, the display will present four numbers to indicate location of obstruction or misalignment. Not a scrolling message.

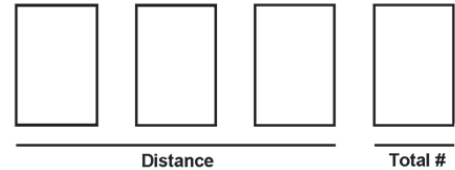

Distance

The first three numbers displayed represent (in inches) the first obstructed or misaligned beam on the guard starting from the cable end of the pylon. The third digit is blank for whole inches and "5" for half inches.

Total

The last digit indicates the total number of beams blocked or misaligned. The digit counts in Hexadecimal (0 to F = 0 to 15 beams). A ">" sign indicates more than 15 beams missing.

"A"=10 beams, "B"=11 beams, "C"=12 beams, "D"=13 beams, "E"=14 beams, "F"=15 beams

Error Conditions

When a scrolling ERROR message is displayed, the end of the message will display a set of numbers to indicate where along the pylon the problem resides.

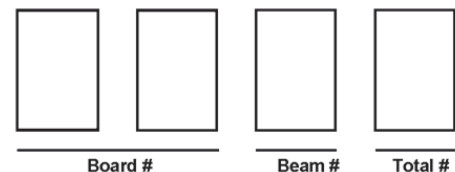

The first two numbers displayed represent the first problem beam on the guard starting from the cable end of the pylon. The third number represents the total number of beams blocked on the guard. Boards inside each pylon are exactly four inches long. Using this you can determine which board in the pylon is bad.

Definitions

BOARD #: Indicates first board on which a problem was detected (01 to 17).
(i.e., 01 = board nearest cable connection)

BEAM #: Indicates first problem beam on the board indicated above (1 to 8).
(i.e., 1 = first beam on board, 8 = last beam on board)

TOTAL #: Indicates total number of blocked beams on the curtain.
(i.e., 1 to 9 beams then A to F = 10 to 15 beams)

Appendix "A"

Diagnostics and Troubleshooting

The Diagnostics Display has two modes of operation: **Status** and **Fault**. If a fault occurs, the display will scroll the fault message until the "FN1" fault reset button is pushed, even if the cause of the fault is corrected and/or you reset the power.

Status Display Messages

Normal Operation

- TEST** Testing internal systems
- RST** Unit waiting for Push of RESET button (located on control module power supply board middle left hand side). If you push the Reset button during normal operation, the unit will go RED and display RST, push again and the unit will start up.
- RDY** Normal operation, no operations selected.
- RdyE** External relay checking feature active
- RdyM** Mute-Out option enabled
- RdyL** Normal, Latching Relay option software selected. Used to reset guard penetration.
- RdyF** Weld flash enabled

Obstruction

- 03 >** This is an example of 15 or more beams blocked starting at 3" up from connector pylon.
- 153** This is an example of 3 beams out starting 1.5" up from connector end of pylon.
- SBLK** Slave microprocessor detected blockage when the Master did not. Some of the receiver signals are so weak that the leading edge of the pulse is missed by the Slave, but the trailing edge is not missed by the Master. Realign the pylons.
- FLIP** Master microprocessor is getting intermittent blockage of the curtain, due to weak signals and is flip-flopping between trying to go GREEN and to RED. Re-align the pylons.

Floating Blank

- FBxy** Floating Blank, x indicates # of beams floating and y indicates option selected or number of beams broken. Yellow LED on the control unit will also light up.
- OBST** Floating Blank Obstruction; more than one object was detected in the curtain. Optional configuration allows two objects for applications where the piece part is bent twice.

Auto Blank

ABxy Auto Blank, x indicates number of beams blanked by object, y indicates option selected or number of beams broken in Mode 3. If no object found during program, the display will read RDY.

In future software versions, the blocked pattern will be stored in permanent memory to allow you to power down without having to reprogram in the object.

PENT Auto Blank in Mode 1 and/or Resettable Latching Relay option in which the curtain was penetrated. By moving the AB keyswitch into OFF/RESET, you can clear this but by moving the keyswitch into MODE 2 or 3 you can clear the PENT without reprogramming in the AB object.

If using the Resettable Latching Relay option, you can reset the cycling the CLOSE contacts S5 located on the door of the control unit. This is where you would connect your remote reset push button.

SIZE Auto Blank programmed object exceeded eight beams total. Optional configuration can increase or decrease this number.

MOVE Auto Blank object moved during normal operations, exposing beams that were previously blocked. This can occur if the object is not fully blocking one of the beams its covering. Optional configuration can ignore movements of the object.

Mute-Out

MUTE Guard has gone into by-pass mode

Cincinnati Interface

CINN When your Cincinnati interface applies +24VDC to terminals 5 & 6, the curtain will go RED.

Fault Display Messages

Resetting Faults: To reset a fault message, push the FN1 button located on the top of the Controller Module and wait for the message to finish scrolling. Powering down will not clear out faults

All faults appear as scrolling messages. Numbers may appear at the end of the message to indicate where the fault occurred in the pylon itself.

42-002/3 R28

Software Revision numbers needed during service (42-002 MASTER chip; 42-003 SLAVE

AutoBlank data corrupted

The number of beams found blocked during programming is no longer equal to the number found in memory. This may indicate that the object moved just as it was being programmed in memory.

CPU clock failure

MASTER has a bad on-board clock circuit in the CPU.

Emitter firing at wrong time xxy

An LED in the Emitter pylon was firing even though it was not told to do so. Could be a short circuit in the emitter pylon or a faulty circuit on the computer board.

Emitter length fault xxy

The length of the Emitter pylon was detected as different from the jumpers S3 set on the door of the Controller Module. xx indicates board number in 4" increments from circular connector; y indicates beam number of that board (1 to 8). Check for a disconnected cable, missing jumper in the pylon, or a faulty circuit on the computer board.

External contact short

External relay checking option has detected that the external contact did not close during a cycling of the curtain from GREEN to RED. Second relay is able to shut down the system.

External contact welded or wire cut

External relay checking option has detected that the external contact did not open within .25sec of the curtain going RED. Second relay is able to shut down the system.

External infrared source detected xxy

Whenever the curtain is RED (at power up) the unit checks for external sources of infrared that might interfere with normal operation of the curtain. xx indicates board number in 4" increments from circular connector; y indicates beam number of that board (1 to 8). This could also indicate that the detector circuit is faulty.

FLIP

MASTER microprocessor is getting intermittent blockage of the curtain due to weak signals and is flip-flopping between GREEN and RED. Re-align the pylons.

Illegal code

MASTER has come across an illegal machine language code inside the ROM of the CPU (this could indicate a bad CPU chip).

Improper operation

MASTER has determined that there has been an improper operation in the CPU and has reset for safety.

Initializing memory

The SLAVE has determined that the EEPROM memory chip does not contain the proper setup values and will attempt to initialize it. This message should only occur during the first time power up. If you get this any other time, it could mean a faulty memory chip or a glitch in the power.

Internal relay bad/missing

One of the Internal relays has a contact that is not open or closed and is determined to be missing. Check for faulty relay contacts or relay position circuitry.

Internal relay is not energizing

Internal relay was told to turn but the contact never closed. Check for a faulty relay or a faulty driver circuit.

Internal relay is stuck on

Internal relay contact has not opened up when requested to do so. Check for a faulty relay, welded contact, or a faulty driver circuit. Second relay is able to shut down the system.

MBLK

MASTER has detected that the pulse width coming from all the receivers is too wide and has determined that the pylons are too close together (< 1'). Turn the pylons away from each other slightly.

Appendix “A”

Diagnostics and Troubleshooting

Mute-out switch fault

The proper sequence of limit switch closures was not correct and so the unit shut down. This could also be due to excessive noise getting into the PLC lines causing misinformation.

No ACK from memory

The SLAVE is requesting error messages from the EEPROM memory chip but has not received an acknowledge from it within the time allotted.

No clock line detected

SLAVE microprocessor could not detect this signal line from the MASTER during a normal scan of the curtain. Check for a faulty circuit in the computer board.

No data line detected

SLAVE microprocessor could not detect this signal line from the MASTER during a normal scan of the curtain. Check for a faulty circuit in the computer board.

No emitter line detected

SLAVE microprocessor could not detect this signal line from the MASTER during a normal scan of the curtain. Faulty circuit in the computer board.

No more error codes

This message appears after the control unit is finished displaying all previously recorded error messages stored in memory. You can start up the curtain by pushing the RESET button when you see this message.

Open LED in emitter pylon xxy

An LED in Emitter pylon was found not firing. xx indicates board number in 4” increments from circular connector; y indicates beam number of that particular board (1 to 8). Could also be a faulty cable, computer board, or R27 on the computer board has burned open.

Power failure reset

SLAVE has reset due to either a power loss or some condition that caused the SLAVE to lockup, in which case the watchdog reset it.

RAM failure

MASTER OR SLAVE has determined that their internal RAM cannot hold data correctly. Glitch in power can cause this.

Receiver length fault xxy

The length of the Receiver pylon was detected as different from the jumpers S3 set on the door of the Controller Module. xx indicates board number in 4” increments from circular connector; y indicates beam number of that board (1 to 8). This could be a cable pulled out, missing jumper in the pylon, faulty circuit on the computer board.

Receiver Oscillating xxy

More than one pulse was detected during reception of the proper Infrared signal. xx indicates board number in 4” increments from circular connector; y indicates beam number of that board (1 to 8). This may indicate that the detector circuit has a problem or a severe external infrared problem was detected.

Reset held down

You have held the reset button down too long. The SLAVE is trying to communicate with the EEPROM memory chip.

SBLK

SLAVE microprocessor detected blockage when the MASTER did not. Some of the receiver signals are so weak that the leading edge of the pulse is missed by the SLAVE but the trailing edge is not missed by the MASTER. Re-align the pylons.

Serial data corrupted

The MASTER has requested data from the SLAVE but the check-sum value received does not match the value calculated from the data received.

- 1) Check for electrical noise. Add MOV's from each leg of safety relay output to earth ground.
- 2) Receiver pylon may be seeing an Emitter pylon of a different light curtain.
- 3) Possibly a faulty computer board or connection.

Serial data transfer incomplete

The MASTER has requested data from the SLAVE and the SLAVE has not responded within the allotted time. This can happen if you hold the RESET button down at the wrong time.

Short LED in emitter pylon xxy

An LED in Emitter pylon was found not firing. xx indicates board number in 4” increments from circular connector; y indicates beam number of that board (1 to 8). Could also be a faulty cable, computer board, or R44 (R27 below Rev 5) on the computer board has burned short.

Slave Found

SLAVE microprocessor has sent an error code to the MASTER and the MASTER is displaying it. Any one the following error messages can also be sent by the SLAVE. Also, you see this message when the SLAVE is sending back error codes from the memory chip during the power up reset sequence.

UNKNOWN CODE

The MASTER has received an error code from the SLAVE for which it has no match. It is possible that the software versions don't match.

Waiting for reset button

Master is waiting for user to push the RESET button to start scanning. This indicates that you pushed the RESET button too soon after getting an error message and prevented the SLAVE from saving the error code in permanent memory. You should wait until the message displays one time before pushing the RESET button.

Watchdog failure reset

MASTER has reset due to either a power loss or some condition that caused the SLAVE to lockup, in which case the watchdog reset it.

OSHA Regulations

1910.217 (C) (3) (iii)

Safeguarding the Point of Operation

(iii) A presence sensing point of operation device shall protect the operator as provided in paragraph (c) (3) (i) (a) of this section, and shall be interlocked into the control circuit to prevent or stop slide motion if the operator’s hand or other part of his body is within the sensing field of the device during the downstroke of the press slide.

- (a) The device may not be used on machines using full revolution clutches.
- (b) The device may not be used as a tripping means to initiate slide motion.
- (c) The device shall not be constructed so that a failure within the system does not prevent the normal stopping action from being applied to the press when required, but does prevent the initiation of a successive stroke until the failure is corrected. The failure shall be indicated by the system.
- (d) Muting (bypassing of the protective function) of such device, during the upstroke of the press slide, is permitted for the purpose of parts ejection, circuit checking, and feeding.
- (e) Refer to ANSI B11.19-2010 for calculating safety light curtain distance from the point of operation.
- (f) Guards shall be used to protect all areas of entry to the point of operation not protected by the presence-sensing device.

1910.217 (C) (3) (iii)

Additional requirements for safeguarding

Where the operator feeds or removes parts by placing one or both hands in the point of operation, and a two hand control, presence sensing device or Type B gate or movable barrier (on a part revolution clutch) is used for safeguarding:

- (i) The employer shall use a control system and a brake monitor which comply with paragraphs (b) (13) and (14) of this section.
- (e) Inspection, maintenance, and modification of presses-
 - (i) It shall be the responsibility of the employer to establish and follow a program of periodic and regular inspections of his power presses to insure that all their parts,

auxiliary equipment, and safeguards are in a safe operating condition and adjustment. The employer shall maintain records of these inspections and maintenance work performed.

1910.212

General requirements for all machines (covers press brakes, hydraulic and pneumatic machines not covered by mechanical power press standards).

- (a) Machine guarding - (1) Types of guarding. One or more methods or machine guarding shall be provided to protect the operator and other employees in the machine area from hazards such as those created by point of operation ingoing nip points, rotation parts, flying chips, and sparks. Examples of guarding methods are: barrier guards, two-handed tripping devices, electronic safety devices, etc.

NOTICE

These are only partial reprints, refer to your Federal Register for total construction, control reliability, and machine guarding requirements for the subject machine being guarded for all applicable OSHA Standards.

Machine Control Reliability Requirements

Control Reliability

“...control circuits shall be designed and constructed so that a single failure or fault within the system does not prevent the normal stopping action from being applied to the press when required, or does not create an unintended stroking action, but does prevent initiation of a successive stroke until the failure is corrected” (ANSI B11.1-2009).

“...control shall be designed to prevent initiation of a stroke signal in the event that a failure occurs within the press control” (ANSI B11.2-2013).

“Robots shall be designed and constructed so that any single, reasonably foreseeable failure will not cause hazardous motion of the robot” (ANSI/RIA R15.06-2012).



"...control circuits shall incorporate features to minimize the possibility of an unintended stroke in the event of the failure of the control component to function properly, including relays, limit switches, and static output circuits" (ANSI B11.1-2009).

"...control system shall be constructed so that a failure within the system does not prevent the normal stopping action from being applied to the press when required, but does prevent initiation of a successive stroke until the failure is corrected" (ANSI B11.1-2009).

"...the control system shall be constructed so that a failure within the system does not prevent the normal stopping action from being applied to the press when required, but does prevent initiation of a successive stroke until the failure is corrected" (OSHA CFR 1910.217).

Safety Guidelines for Management

Operational Safety

1. Appoint a Safety Coordinator to be responsible for safety regulations, requirements, and suggestions. He must review and investigate all accidents and "close calls."
2. Establish and issue safety rules. Inform each employee of his responsibilities. Make sure he understands them and knows what is expected of him.
3. A thorough review and an early inspection must be made of existing presses, dies, and point of operation guarding to attain the degree of responsibility required by ANSI B11.1-2009 Safety Standards and Federal State laws. Review what mandatory modifications are necessary.
4. Equipment that is no longer safe and that cannot be economically upgraded should be destroyed.
5. Never allow persons legally under age to operate or assist in the operation of machinery.
6. All personnel must be properly trained to eliminate accidents and injuries.
7. Regardless of the operator's experience, education, or language barrier, it is the responsibility of the supervisor to give him a thorough explanation with each new job assignment.
8. No employee should be given a work assignment that he does not fully understand. Only properly instructed and thoroughly trained personnel should be assigned to work on or with any machine.
9. It shall be the responsibility of the employer to provide an adequate, clean, safe, and uncluttered work area around each machine.
10. If a malfunction is reported, stop the machine immediately, correct the problem, then resume production.
11. Investigate all accidents and close calls. Analyze the reason for occurrence. Take action to prevent recurrence. Keep records of the investigation and preventative steps that were taken.
12. Only employees who understand the machines, operation and safety requirements, and who are able to communicate this knowledge should be given the responsibility of instructing and training others to perform as operators.
13. Management must decide that personnel protective safety equipment is required to perform each job safely. Items such as safety glasses, shoes, gloves, helmets, hand pads, spats, protective sleeves and material handling equipment are common in the metal working industry. If noise levels are excessive, protective headsets and earmuffs are recommended.
14. When designing point of operation guarding, the manufacturing process should be weighed heavily in favor of operational safety.
15. Establish safe and convenient material handling methods and procedures.
16. Post in convenient areas the names, addresses, and phone numbers of physicians and hospitals, and members of the organization who are to be called in case of emergency.
17. All equipment must be electrically connected according to the National Electric Code and be consistent with other accepted practices.
18. Provide adequate and proper fire protection equipment.



Power Press Guarding

1. Press manufacturers do not know and cannot foresee the magnitude of potential applications of power presses. Therefore, only the press user can determine the type of guards that have to be used in order to perform the job safely. It is the responsibility of the user management to make certain that point of operation guarding and other necessary safety devices are installed. The press should be guarded in such a manner that it is impossible for the operators to place their hands or any other part of the body in the die area.
2. The press user should become thoroughly acquainted with the safety devices commonly employed in power press operations.
3. Feeding devices are strongly recommended, since they remove the operator from the die area, and therefore allow more effective utilization of guards and safety devices.
4. Do not release a press for production before installing and testing all guards and covers.
5. Make frequent evaluation checks of all guarding and devices while the press is running. Correct all unsafe findings immediately.

Power Press Care through Inspection and Maintenance

1. All maintenance and inspection personnel should be specifically instructed, and must understand proper maintenance and inspection procedures contained in this manual.
2. Set up a daily, weekly, and monthly press inspection program. Use a checklist and verify that the job is done correctly.
3. Establish a preventative maintenance program. Records of all maintenance work performed must be kept.
4. Since all equipment has a limited life, quality maintenance personnel are required to obtain maximum usage of your equipment.
5. Releasing a power press for production following maintenance should be the responsibility of a qualified individual assigned by management.
6. To maintain the original level of press reliability, careful inspection of mechanical, electrical, and pneumatic areas must be made. This may give an advance warning of a hazard which then can be corrected to prevent possible injuries and damage.

Safety Enforcement

In order to have an effective safety program, management at all levels must enforce every safety rule and regulation. Strong disciplinary measures are sometimes required. They should consist of a warning, written reprimand, work suspension, transfer, demotion, or possibly a dismissal. All infractions must be reported and recorded. Once an infraction is noted, it shows that an unsafe practice or condition has existed. This may be the result of poor planning or improper training and instructing. The reason for the infraction should be analyzed in order to take corrective action.

Supervisor Training

It should be the responsibility of management to instruct their supervisors on safety, giving job instructions, supervising operators, determining accident causes, and building safety attitudes among the machine operators. Accidents can occur due to inadequate training of supervisors.

Operator Training

It shall be the responsibility of management to insure proper training of operators. A specific training program should be instituted to instruct the operator in safety, proper usage of the equipment, and correct operational procedure in performing each and every job. In addition to the supervisor, the operator should be familiar with the proper guarding of the point of operation. Never permit an operator to start a job without complete instructions from his immediate supervisor.



Figure 14: Controller Module Replacement Parts

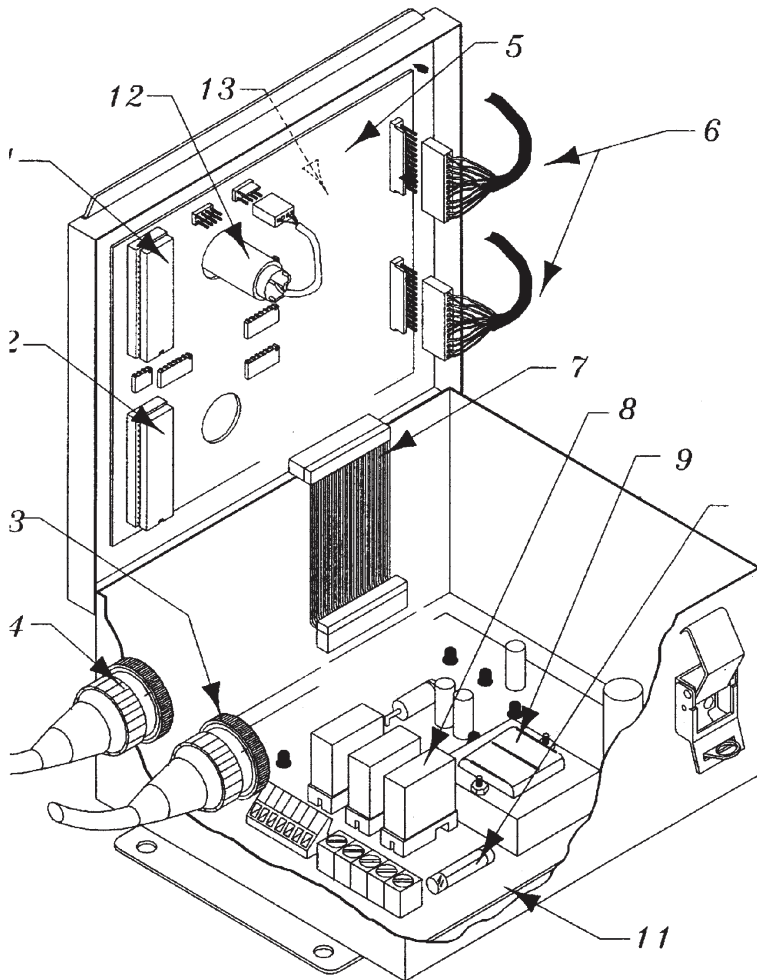

- 1 42-003 Slave (spec. REV #)
- 2 42-002 Master (spec. REV #)
- 3 Receiver
- 4 Transmitter
- 5 52-004 Computer Bd. Assm.
- 6 45-003 Connector Cable
- 7 43-003 Ribbon Cable
- 8 32-001 or 32-098 (green) Safety Relay
- 9 41-004 Transformer

- 11 52-006 Power Supply Bd. Assm.
- 12 52-073 Key Switch Assm.
- 13 26-030 OF Front Label
26-031 AB Front Label
26-032 FB Front Label

NOTE: Include Model and Serial Number with all orders.

TABLE 1

Spec	Rx or Tx
52-097	5' cable
52-098	8' cable
52-095	10' cable
52-096	15' cable
52-094	20' cable
52-099	25' cable
52-100	30' cable
52-101	35' cable
52-102	40' cable
52-103	45' cable

NOTE:

- 42-002 & 42-003 computer chips, must specify square or rectangle shape.
- 32-001 White, Clear, or Blue are 2 pole Safety Relays.
- 32-098 Green is a 3 pole Safety Relay.

- 11-183 Standard Single pedestal mounting bracket
- 11-184 Special Dual pedestal mounting bracket.
Has 2 mounting studs 90deg apart. Allows both Emitter & Receiver pylon on 1 pedestal. Requires SMB option on pylons
- 21-019 Rubber Shock-Mount (Male-Female) 1" dia x 1" tall
5/16-18 thread

Appendix "C"

Replacement Parts

Figure 15: Pylon Replacement Parts

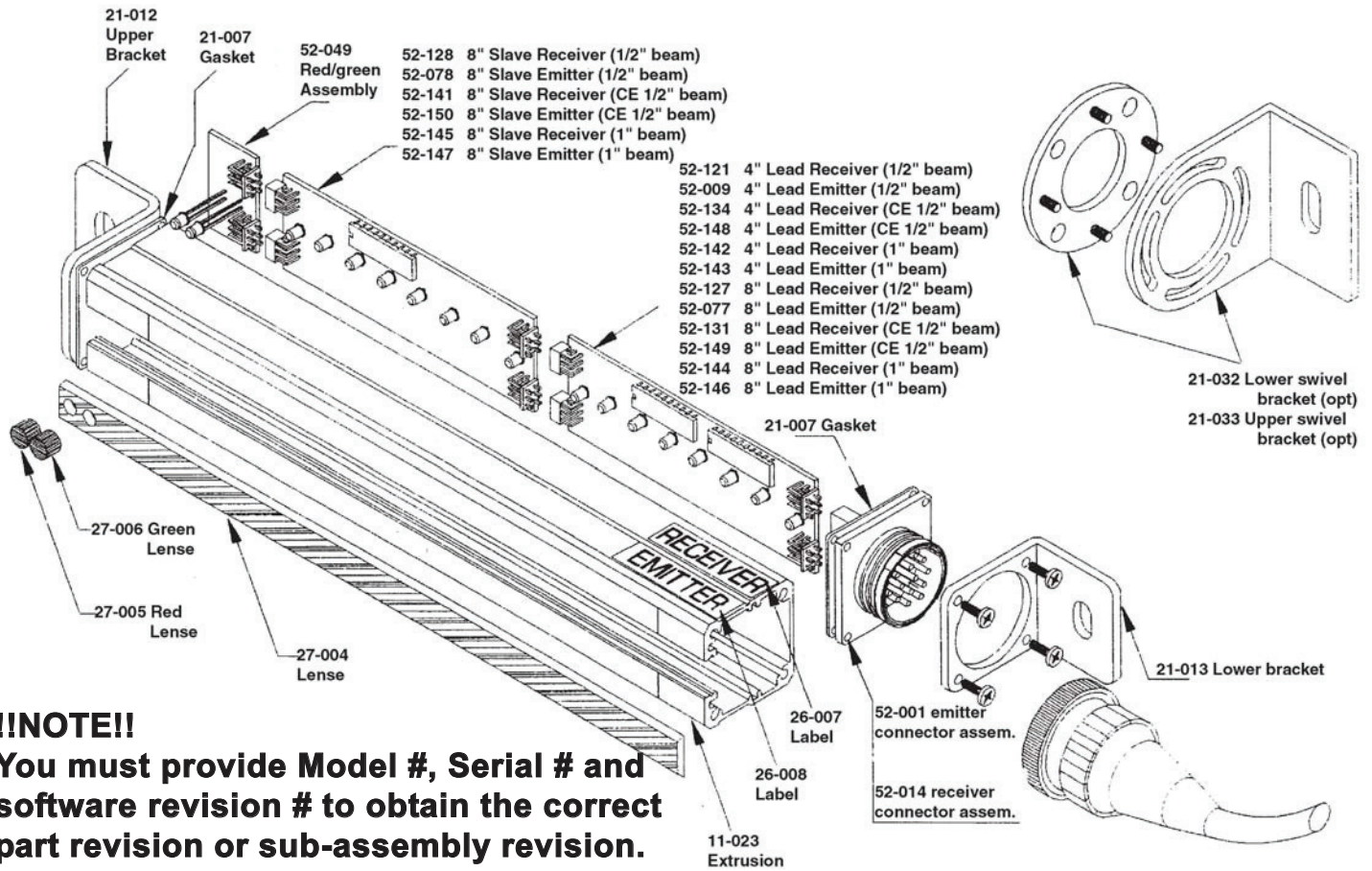

!!NOTE!!
You must provide Model #, Serial # and software revision # to obtain the correct part revision or sub-assembly revision. An individual Part# may have been revised since your unit was purchased.

Part Numbers for Units made prior to 1998

- 52-013 4" Slave receiver
- 52-080 8" Slave receiver
- 52-012 4" Lead receiver
- 52-079 8" Lead receiver

Model MG or DR USB Diagnostic Codes: Master Controls USB port

NOTICE

You must install the Silabs CP210x USB driver on your windows PC. Check your Device Manager for Silabs COM port#. You read the port at 115200 Baud 8N1

Char	Description	
B or b	First or Second Pylon set Blocked	repeats when # of blocked beams changes
M or m	First or Second Pylon set Blocked during MUTE-OUT condition	Guard stays GREEN
C or c	First or Second Pylon set Cleared after a Block	
E or e	First or Second Pylon set no Blocked beams during MUTE-OUT condition	
K	Light Curtain in MUTE-OUT (Guard was GREEN before going into MUTE-OUT)	
k	Light Curtain no longer in MUTE-OUT	
S	Check EEPROM	
Ee	Start & Stop ReWriting EEPROM	Should only happen 1 st time programmed
Q	Fault found active in EEPROM at Startup	Previously powered down with an uncleared Fault
E	AutoBlank load	Should always see this
	"Soft Ver= R34r.1012.MG"	Scroll this string on LED display Only RST F1 push can interrupt this
M	Version Display scroll finished	
	"RST"	String on LED display Then jmp to FAULT routine
Fx	Enter Fault() routine x: 0=Slave in Fault() routine, 1=Slave not in Fault() routine	Should be F0
W	Writing to EEPROM new Fault code	
V<cr>	Clearing Active Fault	Someone Hit RESET button while in a Fault
x y	x & y: upper and lower bytes of Fault Code just cleared.	Displayed in HEX
z	Return from Fault() routine	Not first time returning
P<cr>	Return from Fault() routine	First time returning
0 1 . 9	9 lines of 2 byte HEX showing the last 9 Fault Codes	First to Last
v	Hold RESET button down at power-up	LED displays 9 fault codes
p	End of Fault	
G	First Time return from FAULT()	
A	Run Initial pylon TEST	One time after power-up only
xxxx m	Pylon length , performing SHORT LED test	1 SCAN of pylon
	"Wait"	Done with initial SHORT LED SCAN
x*	If numbers appear without an F, then problems communicating with Slave	
g	Bad Auto Blank memory	

See page D-2 for instructions.

Appendix "D"

USB Diagnostic Codes

Model MG or DR USB Diagnostic Codes: Master Controls USB port Cont.

NOTICE

You must install the Silabs CP210x USB driver on your windows PC. Check your Device Manager for Silabs COM port#. You read the port at 115200 Baud 8N1

Fault Codes: in HEX code

Mute-out switch fault "	01		
Open LED in emitter pylon "	02	Short LED in emitter pylon "	03
Emitter length fault "	04	Receiver length fault "	05
		External contact welded or wire cut "	06
External contact short "	07	Internal relay is stuck on "	08
Internal relay is not energizing "	09	No data line detected "	0A
No clock line detected "	0B	No emitter line detected "	0C
External infrared source detected "	0D	Internal relay bad/missing "	0E
Ram failure "	0F	Power failure "	10
Watchdog failure "	11	Serial data corrupted "	12
Serial data transfer incomplete "	13	Receiver bad "	14
Emitter on at wrong time "	15	Receiver oscillating "	16
NO MORE FAULT CODES "	17	Initialize memory "	18
IIC bad "	19	AB data corrupted "	1A
Reset held down "	1B	No Ack from memory "	1C
Short det. bad "	1D	ESTOP OPENED "	1E
Not Synced up with Slave "	1F	51 "	20
Slave Found: "	21	Improper operation "	22
NO Message FOUND "	23	Clock did not drop "	24
Old FAULTS from Memory: "	25	End of Memory "	26
" ----- "	27		

Proper power up example: SEMFOP <CR> 10 lines of EEPROM memory <CR> GA0024m (for a 24 beam length guard)

Blocked Beam pattern display:

If you transmit the ASCII character 'B' via the USB port, the Microguard will return a string of ASCII character 1's and 0's based on the beam blockage.

The start of the string represents the beam closest to the cable end, and the end of the string is represented by the ASCII character '@'

0 = clear beam

1 = blocked beam

Example for an MG-04-0F-20 model (which has a total of 8 beams):

Send 'B', then you Receive 01100000@

This indicates 2 blocked beams (2nd and 3rd beams from the cable end)

WARRANTY

Manufacturer warrants that this product will be free from defects in material and workmanship for a period of one year from the date of shipment thereof. Within the warranty period, manufacturer will repair or replace such products which are returned to it with shipping charges prepaid and which will be disclosed as defective upon examination by the manufacturer. This warranty will not apply to any product which will have been subject to misuse, negligence, accident, restriction, and use not in accordance with manufacturer's instructions or which will have been altered or repaired by persons other than the authorized agent or employees of the manufacturer.

DISCLAIMER

The provisions of the paragraph "Warranty" are the sole obligations of the manufacturer and exclude all other warranties of merchantability, expressed or implied. Further, there are no warranties which extend beyond the above warranty.

DISCLAIMER

Pinnacle Systems, Inc. does not assume liability for the contents of this publication or the use of any products described. Pinnacle Systems, Inc. reserves the right to make changes to the products or any catalogs without further notice.

ERRORS AND OMISSIONS

Information presented by Pinnacle Systems, Inc. has been checked and is believed to be accurate; however, no responsibility is assumed for clerical, typographical or proofreading errors or omissions.

LIMITATION OF LIABILITY

In the event of any claim or breach of any obligations of manufacturer under any order, whether expressed or implied, and particularly in the event of any claim or a breach of the warranty or warranties contained in the paragraph "Warranty" or of any other warranties, expressed or implied which might, despite the paragraph entitled "Disclaimer," be determined to be incorporated in any order, the company shall under no circumstances be liable for any consequential or special damages, either in law or in equity, or for losses or expenses or claims for the same arising from the use of, or inability to use, the products of the manufacturer for any purpose whatsoever.

WARNING

The entire machine safety system must be tested at the start of every shift. Machine testing should include: (1) proper machine operation and stopping capability; and (2) verification of proper installation and settings of all point of operation guards and devices before the operation is released for production.

CHANGE IN SPECIFICATIONS

Product specifications and accessories may be changed at any time based on improvements and other reasons. It is our practice to change part numbers when published ratings or features are changed, or when significant construction changes are made. However, some specifications of the Product may be changed without any notice. When in doubt, special part numbers may be reassigned to fix or establish key specifications for your application. Please consult the factory.



PINNACLE

S Y S T E M S , I N C .

Sales and Marketing Offices

Customer Service: (630) 443-8542

United States

Pinnacle Systems, Inc.
P.O. Box 100088
Pittsburgh, PA 15233
Toll Free Number: 800-569-7697
Direct Number: 412-262-3950
Fax: 412-262-4055

Canada

Pinnacle Systems, Inc.
8-1734 Orangebrook Court
Pickering, Ontario L1W 3G8
Toll Free Number: 888-285-8885
Direct Number: 905-831-1111
Fax: 905-831-4064

We have designed our equipment to the very highest performance and safety standards known to the current technological state of the art, as evidenced by our U.S.A. and foreign patents issued and pending. However, the installation, usage, suitability, and fitness of our equipment for any purpose, known or unknown, is interdependent upon the performance of other equipment not manufactured, installed, secured or maintained by Pinnacle Systems, Inc.

We cannot and do not accept responsibility for any overall system performance when factors, such as these, are beyond our control.

www.pinnaclesystems.com

sales@pinnaclesystems.com
service@pinnaclesystems.com