

NEW
NSD Switching
DEVICE

Safety Mat System



NSD-TR-01
Metal Box Controller



NSD-DR-01
Basic DIN-rail Controller



NSD-DR-04
DIN-rail Controller
with Diagnostics

Installation and Operation Manual

NSD Safety Mat System

Installation and Operation Manual

Pinnacle Systems, Inc.

3715 Swenson Avenue
St. Charles, IL 60174

P/N: 28-045r2.0

Customer Service: 630-443-8542 (CST)
(Please have Model #, Serial #, and Software Rev # Available)

Sales and Marketing: 800-569-7697 (EST)

Proper Use and Limitations

The NSD Safety Mat System is critical for operator safety. Repairs should only be made by factory authorized personnel. The manufacturer cannot be held responsible for your repair attempts or the unit's subsequent safe operation.

As the NSD Safety Mat System is a single function device, that of sensing an unauthorized intrusion into a guarded area while simultaneously determining that it is capable of sensing such an intrusion, any internal malfunction will manifest itself with a RED condition shut down. The manufacturer will not supply individual component parts of any circuit board but will supply the individual circuit board complete.

The information disclosed herein includes proprietary rights of the manufacturer. Neither this document nor the information disclosed herein shall be reproduced or transferred to other documents, used or disclosed to others for manufacturing purposes, or for any other purposes, except as specifically authorized in writing by the manufacturer. If this manual is supplied in connection with the sale or delivery of manufacturer's equipment, it is to be used solely for maintenance, repair or installation of such equipment.

Warnings and Warranty

Manufacturer warrants that this product will be free from defects in material and workmanship for a period of two years from the date of shipment thereof. Within the warranty period, manufacturer will repair or replace such products which are returned with shipping charges prepaid and which will be disclosed as defective upon examination by the manufacturer. This warranty will not apply to any product which will have been subject to misuse, negligence, accident, restriction, and use not in accordance with manufacturer's instructions or which will have been altered or repaired by person's other than the authorized agent or employees of the manufacturer.

Disclaimer

The provisions of the "Warranty" paragraph above are the sole obligations of the manufacturer and exclude all other warranties of merchantability, expressed or implied. Further, there are no warranties which extend beyond the above warranty.

Limitation of Liability

In the event of any claim for breach of any obligations of manufacturer under any order, whether expressed or implied, and particularly in the event of any claim of a breach of the warranty or warranties contained in the paragraph "Warranty" or of any other warranties, expressed or implied which might, despite the paragraph entitled "Disclaimer," be determined to be incorporated in any order, the company shall under no circumstances be liable for any consequential or special damages, either in law or in equity, or for losses or expenses or claims for the same arising from the use of, or inability to use, the products of the manufacturer for any purpose whatsoever.

The manufacturer has designed this equipment to the very highest performance and safety standards known to the current technological state of the art. However, the installation, usage, suitability, and fitness of our equipment for any purpose, known or unknown, is interdependent upon the performance of other equipment not manufactured, installed, secured or maintained by the manufacturer. We cannot and do not accept responsibility for any overall system performance when factors, such as these, are beyond our control.

WARNING: The entire machine safety system must be tested at the start of every shift. Machine testing should include: (1) proper machine operation and stopping capability; and (2) verification of proper installation and settings of all point of operation guards and devices before the operation is released for production.

Overview

Circuit Description.....	1
--------------------------	---

Specifications.....	2
---------------------	---

Dimensions

1. NSD-TR-01 (Metal Box) Controller.....	3
2. NSD-DR-01 (Basic DIN-rail) and NSD-DR-04 (DIN-rail with diagnostics) Controllers	3

Installation and Operation

Mat Installation.....	4
-----------------------	---

Controller Installations

NSD-TR-01 (Metal Box) Controller.....	4
NSD-DR-01 (Basic DIN-rail) Controller	5
NSD-DR-04 (DIN-rail with diagnostics) Controller.....	5

Operation

1. Stop Circuit (application)	6
2. Manual/Automatic Reset	6
3. External Relay Checking	6

Wiring Diagrams

1. NSD-TR-01 (Metal Box) Controller.....	7
2. NSD-DR-01 (Basic DIN-rail) Controller	8
3. NSD-DR-04 (DIN-rail with diagnostics) Controller.....	9

NSD-DR-04 (DIN-rail with Diagnostics) Accessible Connections	10
--	----

NSD-DR-04 (DIN-rail with Diagnostics) Board Connector Layout	11
--	----

Appendix A: Troubleshooting

NSD-TR-01 (Metal Box) and NSD-DR-01 (Basic DIN-rail) Controllers.....	AA-1
NSD-DR-04 (DIN-rail Controller with diagnostics)	AA-1
DeviceNet (for NSD-DR-04 only)	AA-3

Appendix B: Safety Guidelines for Management

Operational Safety	AB-1
Safety Enforcement	AB-2
Supervisor Training	AB-2
Operator Training	AB-2

Overview

NSD Safety Mat System

Overview

The NSD Safety Mat System contains two independent control circuits which allow for shut down due to any single failure in one of the control circuits. The N.O. output circuit is controlled by two captivated contact relays in series which are both monitored. If the contact in one relay should stick closed (i.e., contact weld) the other relay will shut down and an LED will indicate the fault, even if the contact on the bad relay opens back up you must reset the power to clear the fault. The relay contact monitoring provides a high degree of user safety.

Circuit Description

The NSD-TR-01 (metal box) and NSD-DR-01 (basic DIN-rail) are alike in that they use discrete logic circuits to detect the mat. The NSD-DR-04 (DIN-rail with diagnostics) is diverse redundant microprocessor driven and has a built-in diagnostics display. A low voltage (24VAC) signal is sent out to the safety mat(s) through two wires. The voltage passes through the mat and back into the NSD control unit through two more wires. Two special optically-isolated diverse redundant circuits look at the signals coming back from the mat(s) detecting the presence of proper positive and negative voltage (AC) levels and output their signals to redundant missing pulse detectors. If the voltage coming back is too high or low, the missing pulse detectors will drop out and de-energize the relay circuit. If the voltage coming back is not AC (missing either positive or negative peaks), then the signal going to the missing pulse detector will disappear which will, in turn, drop out and de-energize the relay circuit.

Redundant relay position detectors watch for a relay contact stuck in the wrong position. The circuits will lock out the reset feature of the NSD control unit if a relay contact is closed when it should be open.

Each relay has its own driver circuit to complete the redundancy of the circuits.

The output relays will de-energize if the voltage coming from the mat(s) is either too high or low (12VAC to 36VAC) or is not AC (i.e., DC), including the following reasons:

1. When you step on the mat, you are shorting out the 24VAC signal going back into the NSD control unit to OV, so the relays de-energize.
2. If you cut any wire going to or coming from the mat(s), the signal going back into the NSD control unit is OV, so the relays de-energize.
3. If any wire going to or coming from the mat(s) is cut and/or shorted to any other mat wire, the signal going back into the NSD control unit is OV, so the relays de-energize.
4. If any wire going to or coming from the mat(s) is cut and/or shorted to an outside AC power source (i.e., 120VAC) the signal going back into the NSD control unit will exceed the 24VAC signal level and the relays will de-energize.
5. If any wire going to or coming from the mat(s) is cut and/or shorted to an outside DC power source (i.e., 24VDC), the signal going back into the NSD control unit will not be an AC signal and the relays will de-energize.
6. If, when you step on the mat, either safety output relay is stuck in the closed position, the NSD control unit will automatically shut down the other relay and lock out and further attempts to reset the unit until the power is reset.

Specifications

NSD Safety Mat System

	NSD-TR-01 Controller (Metal Box)	NSD-DR-01 Controller (Basic DIN-rail)	NSD-DR-04 Controller (DIN-rail with Diagnostics)
Enclosure:	NEMA 12, 13, IP 54	NEMA 1, IP 32	NEMA 1, IP 32
Input Power:	120VAC +/- 10% @ 3 watts 50-60 Hz fused	24VDC +/- 20% @ 7 watts	24VDC +/- 20% @ 7 watts
Category/Type:	4	4	4
Relay Style:	Monitored force-guided captive contact safety relays	Monitored force-guided captive contact safety relays	Monitored force-guided captive contact safety relays
Relay Configuration:	2 N.O. Safety Relays (closed when circuit activated) 1 Aux Output N.O. or N.C	2 N.O. Safety Relays (closed when circuit activated) 1 Aux Output N.O. or N.C	2 N.O. Safety Relays (closed when circuit activated) 1 Aux Output N.O. or N.C. 1 Fault Relay N.O.
Safety Relay Rating:	4A @ 220VAC	4A @ 220VAC	4A @ 220VAC
Reset Provisions:	Manual or Automatic	Manual or Automatic	Manual or Automatic
Controller Response Time:	15 msec.	15 msec.	19 msec per mat input used
Self-Checking Intervals:	Every 20 msec.	Every 20 msec.	Every 20 msec.
Number of Isolated Zones:	1 to 13 (customer specified)	1 per controller	1 per controller
Maximum Number of Mats:	20	20	4 with homerun wiring 20 with daisy chain wiring
External Reset Provision:	Green push button	Green push button	Green push button
Indicators:			
<i>Internal (on board):</i>	<u>Yellow LED</u> = +5VDC power supply <u>Red LED</u> = Normally dim, brighter when mat is stepped on. Cut wire detected when not lit. <u>Green LED</u> = Relay contact detected closed when it should have been open when not lit. Must reset power to clear.	<u>Green LED(s)</u> = next to each relay (3) <u>Red LED</u> = +12V <u>Yellow LED</u> = +5V <u>Green LED</u> = -5V	<u>Red LED</u> = +12VDC <u>Green LED</u> = +20VDC <u>Yellow LED</u> = +5VDC <u>Green LEDs</u> = one for each relay (4 total)
<i>External:</i>	<u>Red LED</u> = 1 or both relays are de-energized. <u>Green LED</u> = All relays are energized.	<u>Red LED</u> = 1 or both relays are de-energized. <u>Green LED</u> = All relays are energized. <u>Yellow LEDs</u> = 2 to show on/off mat. <u>Yellow LED</u> = relay fault if it turns off.	<u>Red LED</u> = 1 or both relays are de-energized. <u>Green LED</u> = All relays are energized. <u>Yellow LEDs</u> = 1 for each mat status — (4 total)
Diagnostic Message Display:	N/A	N/A	Built-in
DeviceNet:	N/A	N/A	Add suffix DN to Model #. See next page for additional information.
Warranty:	2 years	2 years	2 years

Specifications

NSD Safety Mat System

Dimensions

NSD-TR-01 (Metal Box Controller)

- Board (NSD-TR-B1): 5" x 7" plate with 4 holes 4-1/4" x 6-1/4" on center.
127mm x 177.8mm with 4 holes 107.95mm x 158.75mm on center
- Box (NSD-TR-01): 8"h x 6"w x 3.5"d (4" x 8-3/4" holes), NEMA 12, 13
203.2mm x 152.4mm x 88.9mm (101.6mm x 222.25mm holes)
- (NSD-TR-02): 12"h x 10"w x 5"d (8" x 12-3/4" holes), NEMA 12, 13
304.8mm x 254mm x 127mm (203.2mm x 323.85mm holes)
- (NSD-TR-03/04): 16"h x 14"w x 6"d (13" x 16-3/4" holes), NEMA 12, 13
406.4mm x 355.6mm x 152.4mm (330.2mm x 425.45mm holes)
- (NSD-TR-05/up): Call for sizes available.

NSD-DR-01 and NSD-DR-04 (both DIN-rail Controller models)

Mounting: 35mm DIN-rail mountable or mounting screws on corners of enclosure requiring

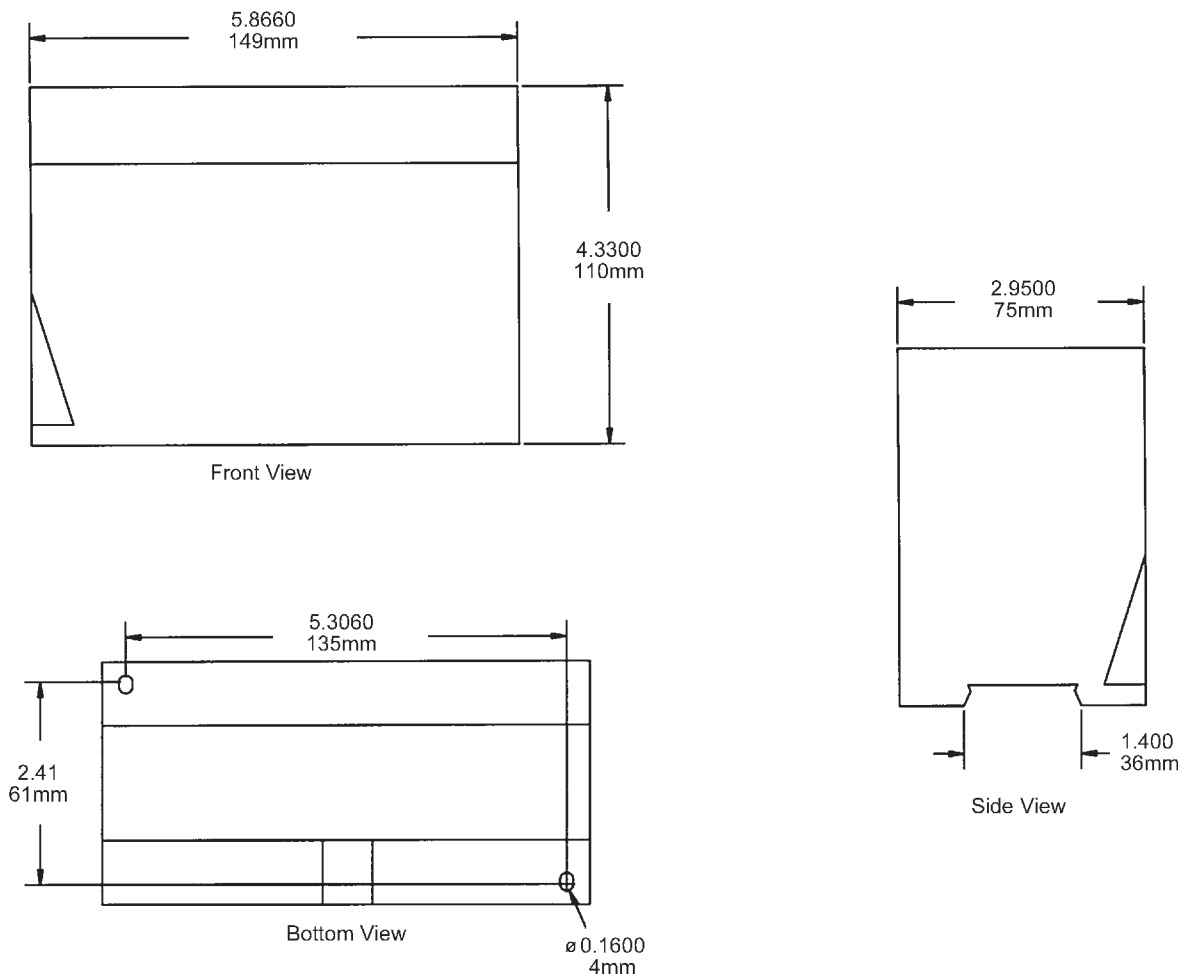

WARNING: The entire machine safety system must be tested at the start of every shift. Machine testing should include: (1) proper machine operation and stopping capability; and (2) verification of proper installation and settings of all point of operation guards and devices before the operation is released for production.

Mat Installation

The NSD mat system has been designed to promote individual mat “homerun” wiring back to the mat controller. This is suggested for easing installation and diagnostics for maintenance troubleshooting. This will also eliminate cumbersome “daisy chain” wiring practices of mat systems. It also eliminates numerous wiring connection points buried under the perimeter trim which are time intensive to troubleshoot.

- 1) Sweep the floor area where the safety mat is to be installed. The floor should be flat and free of foreign material.
- 2) Locate the safety mat in the desired location. For future reference, install the mat with the label side up.
- 3) Slide the black wire raceway component under the mat edge (Part #M002). Refer to Figure 1 below for proper component positioning.

NOTE: The wire raceway component must be installed whenever the surface perimeter trim component is used.

- 4) Route the wire/plug assembly on the raceway toward the mat controller location.

- 5) Lay the aluminum perimeter trim piece around the mat assembly. Determine where the mat wiring will exit the trim and notch the trim and wire raceway for the wire to exit the assembly.
- 6) If surface metal raceway is used to route the wiring (Part #M005 or M006) from the mat assembly across the floor toward the mat controller, it should be aligned with the notch in the perimeter trim and anchored to the floor. Route wires accordingly and snap cover plate over the wires.
- 7) Slide the perimeter trim over the wire raceway component and align over the mat edge. Drill the perimeter trim and floor for securing the perimeter trim to the floor with anchoring screws and floor anchors.
- 8) If a multiple mat assembly is to be installed, use the aluminum active coupler component (Part #M003) to connect mats end to end or side to side. Refer to Figure 1 below.

Controller Installation

NSD-TR-01 (Metal Box) Controller

IMPORTANT: The NSD-TR-01 Controller provides both N.O. and N.C. output circuits, but only Terminals 5-6 (N.O.) are safety monitored and should be used in series with your stop circuit. Terminals 7-8-9 are NOT monitored; this output should only be used as an auxiliary signal line.

Figure 1: Cross Section View of Mat Assembly Active Edging

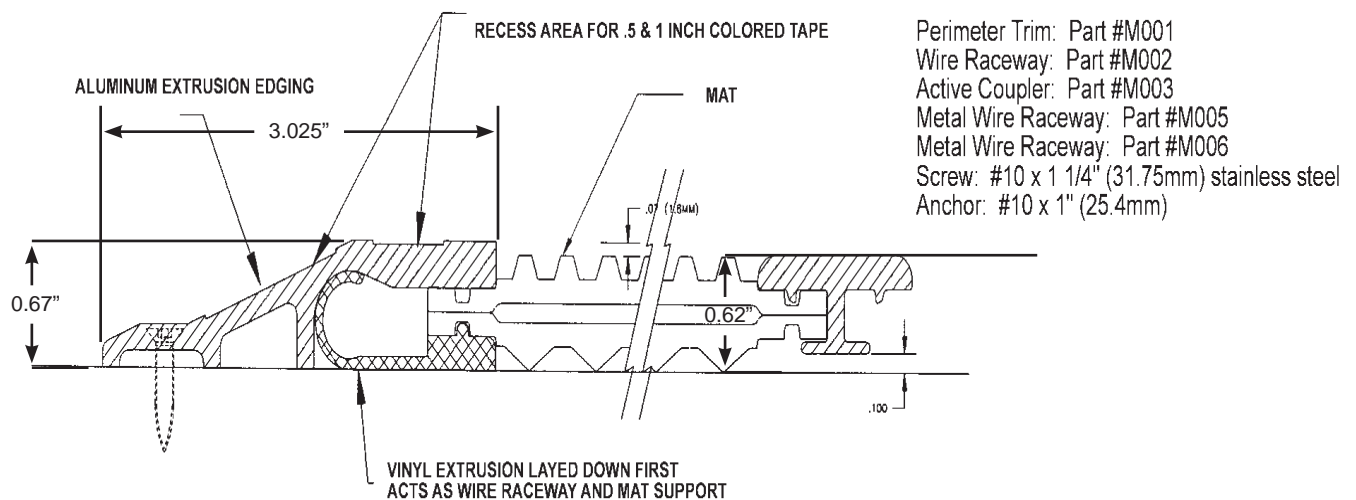

Installation and Operation

NSD Safety Mat System

- 1) Mount the NSD-TR-01 (metal box) where you can get access to it without having to step on the mat.
- 2) Attach 120VAC to Terminals L1 and N2 and Earth ground to GND.
- 3) Wire mat to terminals 1-2-3-4 (1=blue, 2=white, 3=black, 4=brown **for a single 4-wire lead mat** and 1=black, 2=red, 3=red, 4=black **for a two-dual lead mat.**) If your mat has two zip cords (two wires in each cord), then one zip cord goes to Terminals 1-2 and the other to Terminals 3-4 (it does not matter which zip cord).
- 4) Wire Terminals 5-6 into your STOP circuit. Terminals 5-6 come from two N.O. contacts in series for safety (see “important” note above).
- 5) Unit is setup for Manual Reset if you have the Green button on the case.
Automatic Reset. disconnect all four wires from Terminals 14-15-16-17.
Remote Manual Reset. Place one pole of any D.P.N.C. button between Terminals 14-15 and the other pole between Terminals 16-17.
- 6) You can use Terminals 7-8-9 for non-safety indicating or monitoring (i.e., strobe lights, PLC).
- 7) External 24VDC Red Zone light goes to Terminals 11-12; 24VDC Green Zone goes to Terminals 12-13; Terminal 12 is 24VDC out.

NSD-DR-01 (Basic DIN-rail Controller)

IMPORTANT: You must use both Terminals 7-8 and 9-10 in your Stop circuit. If you have one Stop circuit, you must jumper Terminal 8 to 9, then use Terminal 7 and 10 in your Stop circuit. **Do not use Terminals 11-12-13 for safety circuits.**

- 1) Mount the NSD-DR-01 (basic DIN-rail Controller) inside an enclosure since all the wiring terminates on the outside of the controller box.
- 2) Attach 24VDC to Terminals 1-2 and Earth ground to Terminal on the right side of the DIN-rail controller box.
- 3) Wire mat to Terminals 3-4-5-6 (1=blue, 2=white, 3=black, 4=brown **for a single 4-wire lead mat** and 1=black, 2=red, 3=red, 4=black **for a two-dual lead mat.**)

- 4) Wire your Stop circuit to Terminals 7 and 10. Place jumper between Terminals 8 and 9 (see “important” note above).
- 5) Unit comes setup in manual mode with a jumper between Terminals 2 and 16 (use the built-in “zone reset” button to clear the zone).
Automatic Reset. Remove jumper wire from between Terminals 2 and 16.
Remote Reset. Wire a N.C. push button in place of the jumper wire.
- 6) You can use Terminals 11-12-13 for non-safety indicating or monitoring (i.e., strobe lights, PLC).
- 7) You can install remote red and green lights (Terminals 14-15). These terminals go to GND when active.

NSD-DR-04 (DIN-rail Controller with diagnostics)

IMPORTANT: You must use both Terminals 4-5 and 6-7 in your Stop circuit. Do not use Terminals 8-9-10-11-12 for safety circuits.

- 1) Mount the NSD-DR-04 (DIN-rail controller with diagnostics) inside an enclosure since all the wiring terminates on the outside of the controller box.
- 2) Select the number of mats (1-4) you want to hook up. Open the DIN-rail box and select the proper jumper settings (see NSD-DR-04 *Jumper Settings, Page 12*).
- 3) Select Automatic or Manual Zone resetting (see *Jumper Settings, Page 12*).
- 4) Select External relay checking (see *Jumper Settings, Page 12*).
- 5) Attach 24VDC to Terminals 1-2 and Earth ground to Terminal 3 of Power/Output connector.
- 6) Wire mat to terminals 1-2-3-4 of each mat connector (1=blue, 2=white, 3=white, 4=brown **for a single 4-wire lead mat** and 1=black, 2=red, 3=red, 4=black **for a single two-dual lead mat.**)
- 7) Wire your Stop circuit to Terminals 4 and 7. Place jumper between 5 and 6 (see “important” note above).
- 8) You can use Terminals 8-9-10-11-12 for non-safety indicating or monitoring (i.e., strobe lights, PLC).

NOTE: Canadian market wiring is black, red, red, black with 18-gauge wiring size.

- 9) You can install remote red and green lights (Terminals 7 and 8 of I/O connector). These terminals go to GND when active.
- 10) Remote Zone reset connects to Terminal 3 of I/O connector.
- 11) If you need to use external relays, then connect external relays to Terminals 1-2 of I/O connector (see below for explanation).

Operation

If you have manual reset (standard), you must push the RESET button to reset the NSD controller.

If you have automatic reset, the NSD Controller will go GREEN when you step off the mat. Automatic reset should not be used in applications where there is no barrier past the mat.

Stop Circuit (application)

Anyone stepping on the mat(s) will automatically shut the machine off. This circuit allows for multiple numbers of mats to be wired in series to protect a very large area around dangerous equipment with only one NSD Controller.

Manual/Automatic Reset

NSD-TR-01 (Metal Box): If nothing is attached to Terminals 14-15-16-17, then the NSD Controller will automatically reset itself. If you have a pushbutton, simply remove all four of these wires from their terminals.

If a 2 pole N.C. push-button contact is placed across Terminals 14-15 and the second pole is placed across Terminals 16-17, then you must use the push-button to manually reset the NSD Controller unit.

NSD-DR-01 (Basic DIN-rail): If you select manual, you will have to go to the control box and press the zone reset button each and every time you step on any mat(s). This requires a jumper wire between Terminals 2 and 16. To remote the zone reset, place a N.C. button in place of the jumper wire.

If you select automatic, the zone will clear itself when you have stepped off the mat(s). Remove the jumper wire from between Terminals 2 and 16.

NSD-DR-04 (DIN-rail with diagnostics): If you select manual, you will have to go to the control box and press the zone reset button each and every time you step on any mat(s). Place jumper across JP3 to activate this feature.

To remote the zone reset, place a N.O. button between Terminal 3 of the Input/Outputs connector and Terminal 2 of the Power Connector.

If you select automatic, the zone will clear itself when you have stepped off the mat(s). Remove jumper across JP3 to activate this feature.

Note: This setting changes all mats. You cannot change some mats to manual and others to automatic.

External Relay Checking

NSD-DR-04 (DIN-rail with diagnostics): This option is selected when you have to switch a large load. This feature allows the NSD to monitor your external relays. This system requires that you use two force-guided relays for the external switching and that the secondary pole of each relay (N.C.) be tied in series back to the NSD control external relay input terminals for each particular zone. Place jumper across JP4 EXT to activate this feature (see Page 10 for wiring diagram).

Installation and Operation

NSD Safety Mat System

Wiring Diagrams

NSD-TR-01 (Metal Box Controller)

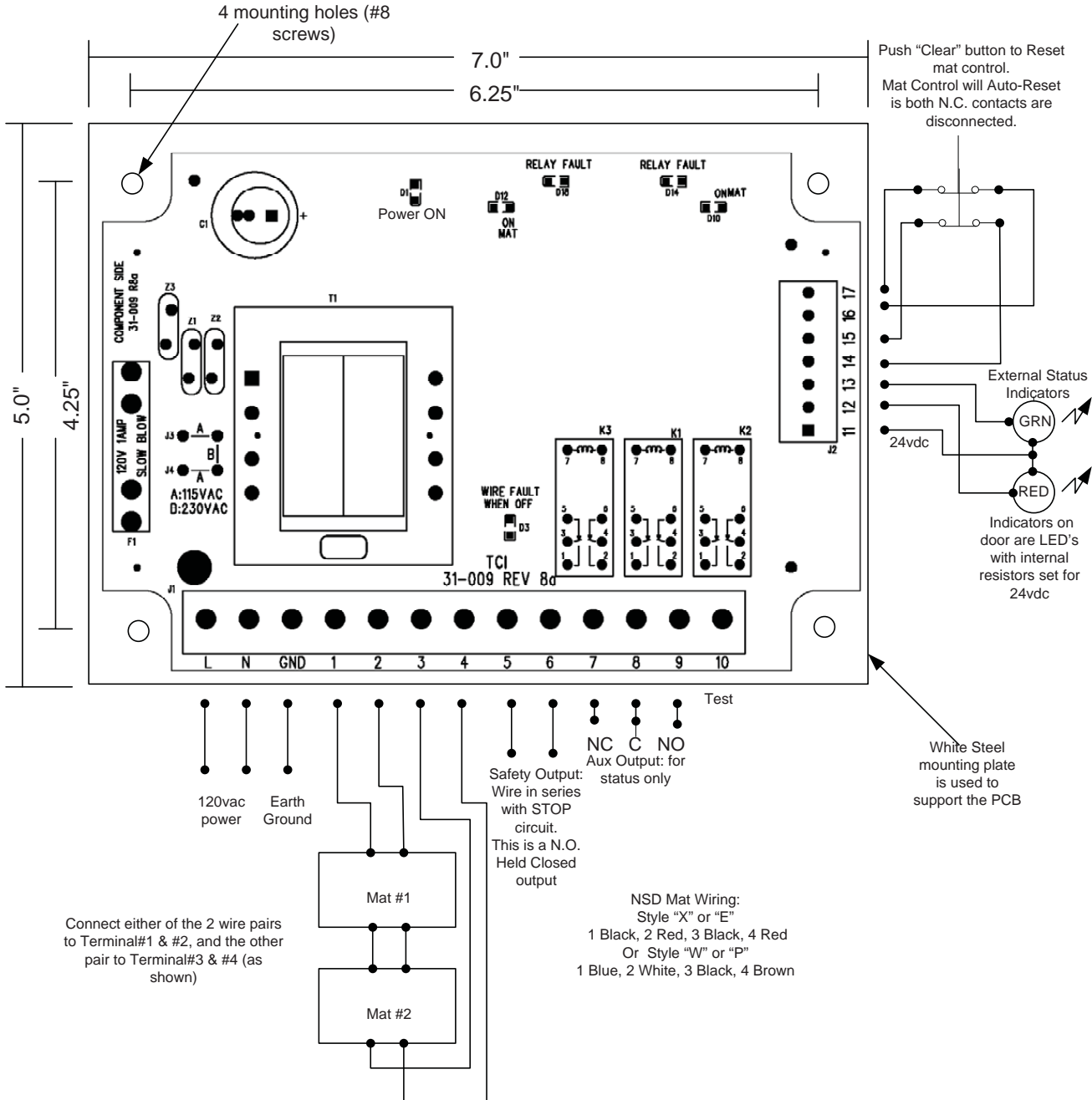

NOTE: If you daisy chain mats, the blue/white is one pair and should go to Terminals #1 and #2. The black/brown is the other and should go to the blue/white pair of the second mat, and so on. The black/brown pair of the last mat goes back to Terminals #3 and #4.

If the mat has two lamp cords, then either pair can go to Terminals #1 and #2 and so on.

Relay Fault LED's D14,D18
(ON=good, OFF=Relay stuck on FAULT)

On Mat LED's D10,D12
(ON=ON mat, OFF=OFF mat)

NOTE: Canadian market wiring is black, red, red, black with 18-gauge wiring size.

NSD-DR-01 (Basic DIN-rail Controller)

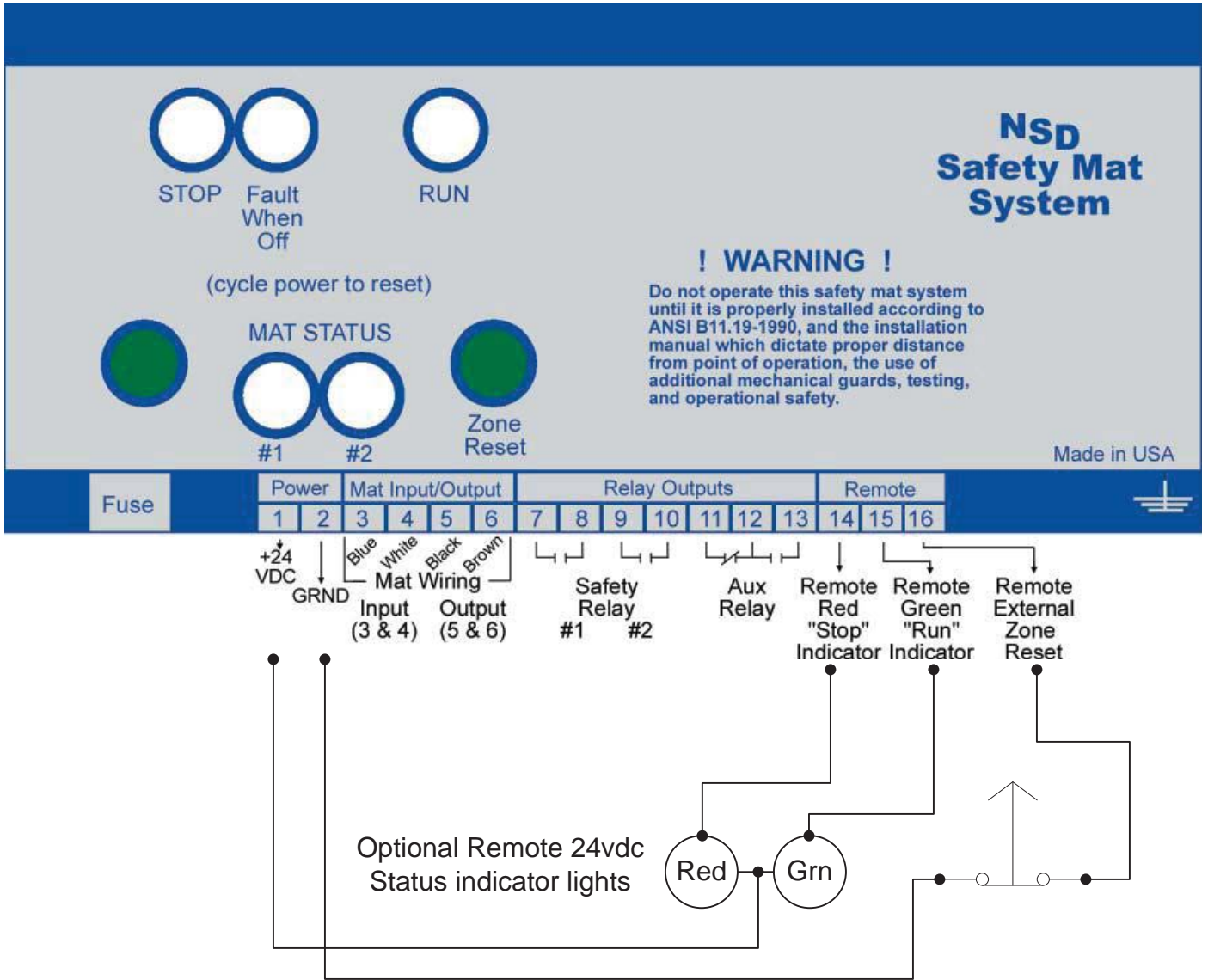

NOTE:
Mat Wiring for Mat Styles "W" and "P" are shown above (Blue, White, Black, Brown)

Mat Wiring for Mat Styles "X" and "E" are Black, Red, Red, Black (and are wired in that order)

Canadian market wiring is black, red, red, black with 18-gauge wiring size.

Note:
Safety Relay outputs are N.O. (Held Closed) and are wired into your STOP circuit(s).
Aux Relay should only be used for indicator lights

Manual Relay Latching Reset: Wire Terminal #2 to #16 and use the Green ZONE RESET button to reset

Optional Remote Latching Relay Reset: Use a N.C. push button wired as shown above

Installation and Operation

NSD Safety Mat System

NSD-DR-04 (DIN-rail Controller with diagnostics)

Mat Wiring per Mat Input

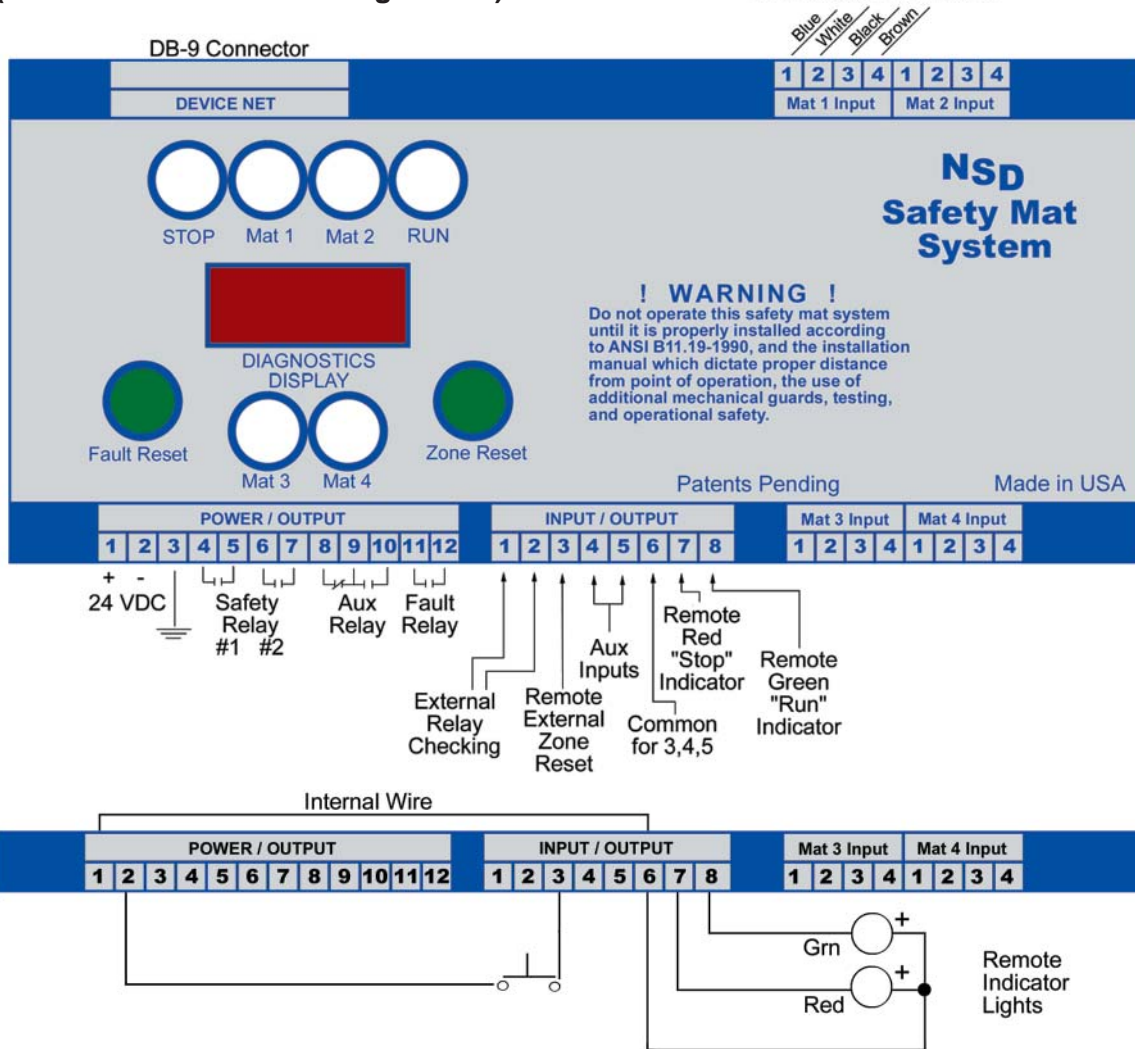

External Relay Checking (optional usage)

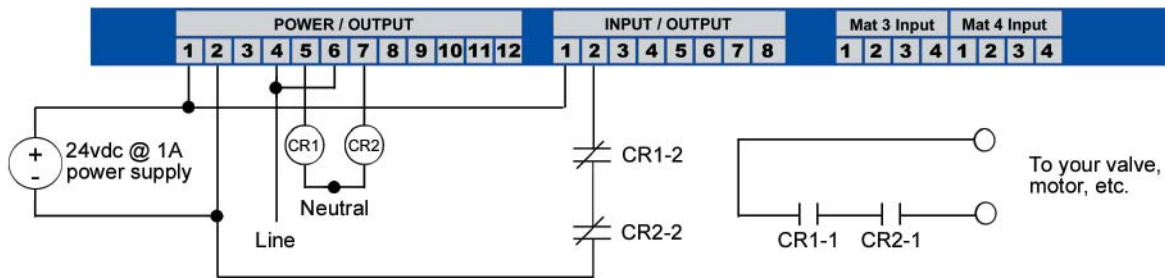

NOTE: Terminal #6 (INPUT/OUTPUT PLUG) is internally connected to Terminal #1 (POWER/OUTPUT) plug. This allows Terminal #6 to provide +24v to the lights for the RSD (Remote Status Display).

NOTE: Canadian market wiring is black, red, red, black with 18-guage wiring size.

REMOTE STATUS DISPLAY

- Green: Terminal #8 (INPUT/OUTPUT)
- Red: Terminal #7 (INPUT/OUTPUT)
- Black: Terminal #1 (POWER/OUTPUT)
- White/Black: Terminal #3 (INPUT/OUTPUT) / Terminal #2 (POWER/OUTPUT)
- 12cond cable: J1 (on left side of diagnostics display)

NSD-DR-04 (DIN-rail Controller with diagnostics) Accessible Connections

J1 Diagnostics display plug (used by remote status display option)
The Plug is located under the top cover on the left side of the controller

External:

POWER/OUTPUT PLUG

Terminal No.	Usage
1,2,3	+POS, -NEG, EARTH GROUND (24VDC ONLY)
4,5	Safety relay N.O. output (dry contact) (held closed when GREEN)
6,7	Safety relay N.O. output (dry contact) (held closed when GREEN)
8,9,10	Auxiliary relay N.C., COM, N.O.
11,12	Fault relay N.O. (open when faulted)

INPUT / OUTPUT PLUG

Terminal No.	Usage
1,2	+pos, -neg External relay checking (option) 24vdc applied across these terminals when external relay is de-energized
3	Remote external zone reset (Ground to reset zone)
4,5	Auxiliary inputs (Ground to activate feature)
6	+24vdc input (Common for terminals 3,4,5) (jumper from term #1 Power/Output)
7	Optional remote RED "STOP" indicator output (Grounded when RED)
8	Optional remote GREEN "RUN" indicator output (Grounded when GREEN)

MAT 1,2,3,4 INPUT

Terminal No.	Usage
1,2	20VDC output to mat (1=blue, 2=white) voltage between 1 & 2 alternates (1=black, 2=red for single two-dual lead mats)
3,4	Return from mat (3=black, 4=brown) (3=red, 4=black for single two-dual lead mats)

DEVICENET PLUG (DB-9 female)

Terminal No.	Usage
2,7	CANL, CANH (twisted pair data lines)
3,6	Ground

NOTE: Canadian market wiring is black, red, red, black with 18-gauge wiring size.

Installation and Operation

NSD Safety Mat System

NSD-DR-04 (DIN-rail Controller with diagnostics) Board Connector Layout

J2,J26	MAT INPUT #1 thru #4	JP1,2	NUMBER OF MATS SELECTION
J1	DIAGNOSTICS DISPLAY (remote)	JP3	MANUAL
J120	POWER/OUTPUT	JP4-6	EXT, AUX1, AUX2
D13,14	Safety relay output on (closed)	D3	+12v supply
D16	Auxiliary relay output on	D1	+5v supply
D15	Fault relay output on (closed)	D23	+20v supply

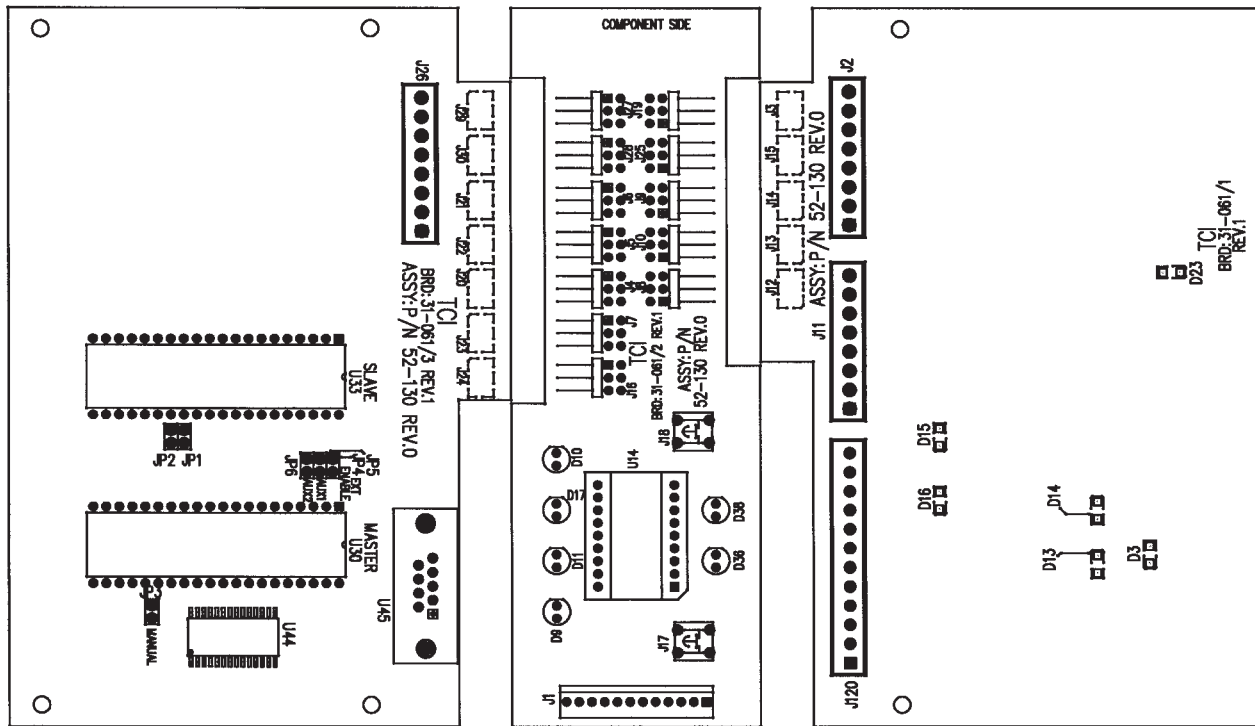

NSD-DR-04 (DIN-rail Controller with Diagnostics)

Jumper Settings

1= jumper install

Number of Mats:

JP2 JP1

0	0	1 mat
1	0	2 mats
0	1	3 mats
1	1	4 mats

JP3

1= Manual relay resetting
0= Automatic relay resetting

JP4

1= External relay checking enabled
0= Disabled

JP5

Not used at this time

JP6

Not used at this time

NSD-TR-01 (Metal Box) and
 NSD-DR-01 (Basic DIN-rail) Controllers

PROBLEM: No indicators are lit

Cause(s):

- 1) Incorrect line voltage OR no line voltage.
- 2) Incorrectly wired.
- 3) Blown fuse.
- 4) Bad regulator.

Cure: Check fuse, then make sure you have line voltage present at the correct terminals and that its within specifications. If it all checks out, then the control board must be replaced.

PROBLEM: NSD control will not go green when reset, relay fault LED is off

Cause(s):

- 1) Noise on the power line caused a glitch in the NSD control.
- 2) Relay contact stayed closed when user stepped on mat.
- 3) One of the redundant control circuits is faulty.

Cure: Remove power to unit for 30 seconds, apply power and hit the RESET button. This should reset the circuits and the NSD control should come back up. Check the relays for signs of contact pitting. Also, it's possible that large voltage spikes on the power line could have caused a glitch in the NSD control and it shut down. If the unit continues have this problem, install MOV's on the power terminals of any nearby motors, or solenoids. These devices cause noise on the power line and the MOV's can usually cure this.

PROBLEM: NSD control will not go green when reset, wire fault LED is off

Cause(s):

- 1) Wires from mat have not been installed correctly.
- 2) One or more of the four wires going out to the mat has been cut.

Cure(s):

- 1) See wiring diagram page for mat wire colors and terminals.
- 2) Repair or replace cut wires.

PROBLEM: NSD control will not go green when reset, all internal indicators are on

Cause(s):

- 1) Object on mat is keeping control RED.
- 2) Short in either the mat or external wires going to the mat.
- 3) You forgot to press the RESET button to reset the mat.

Cure: Remove the mat wires from the control unit and use an OHM meter to check for a short between the wires or between each pair of wires on the mat. If there is a short, check for physical signs of damage to the wiring or the mat. The mat will require replacement if the short is not in the wiring.

NSD-DR-04
 (DIN-rail Controller with diagnostics)

PROBLEM: Mat wiring fault

Cause(s):

- 1) Low voltage on input that should be ground.
- 2) High voltage on input that should be ground.

Cure: Bad wiring, bad comparator, or bad mat.

PROBLEM: Circuit fault

Cause(s):

- 1) Voltage to mat below low setpoint.
- 2) Voltage to mat below high setpoint.
- 3) One of the redundant circuits indicates ON mat, the other indicates OFF mat.
- 4) One of the redundant circuits indicates OFF mat, the other indicates ON mat.
- 5) High voltage on input that should be ground.

Cure: Bad wiring, bad comparator, or bad mat.

PROBLEM: Zone # out of sequence

Cause: The master and slave processors disagree on which sequence they are on.

Cure: An external electrical noise could be causing one of the processors to loose sequence.

Appendix "A"

Troubleshooting

PROBLEM: Zone 1 relay off, should be on
Cause(s): Relay found in the wrong state; circuitry failure or relay failure.
Cure: Call for assistance.

PROBLEM: External relay contact welded/cut
Cause: External relay check input remained open (0 volts) while the zone was de-energized.
Cure: When the zone is de-energized (RED), your external relay must close within 1/4 second.

PROBLEM: External relay contact short
Cause: External relay check input remained closed (voltage applied) while the zone was energized.
Cure: When the zone is energized, the secondary pole of your external relay (N.C.) must open up within 1/4 second.

PROBLEM: Mat # out of sequence
Cause: The master and slave processors disagree on which sequence they are on.
Cure: Could have an electrical noise problem causing one of the processors to loose sequence.

PROBLEM: Ram failure
Cause: Microprocessor failed the internal memory test.
Cure: Call for assistance.

PROBLEM: Power failure
Cause: Circuitry failure; brown out.
Cure: Call for assistance.

PROBLEM: Watchdog failure
Cause: Watchdog circuitry failure.
Cure: Call for assistance.

PROBLEM: Serial data corrupted
Cause: Electrical noise getting into the control box causing one of the computer to reset.
Cure: Place MOV's across the coil of any device (outside this control) switched on/off by the relay outputs of this controller.

PROBLEM: Serial data transmission incomplete
Cause: Electrical noise getting into the control box causing one of the computer to reset.
Cure: Place MOV's across the coil of any device (outside this control) switched on/off by the relay outputs of this controller.

PROBLEM: Master relay on, Slave relay off
Cause(s): The master processor disagrees with the slave.
Cure: Call for assistance.

PROBLEM: Slave relay on, Master relay off
Cause: The slave processor disagrees with the master.
Cure: Call for assistance.

DeviceNet

Applicable for the DIN-rail (with diagnostics) only

Vendor ID code = 0459

Diagnostics Display

"OK U"

Devicenet unconnected (may be unplugged from network)

"OK C"

Devicenet connected but not allocated (passed duplicated mac id check)

"OK A"

Devicenet allocated (in service)

"OK F"

Devicenet faulted out (mat controller will work, but not devicenet)

User adjustable MAC_ID (default = 63)

If the NSD controller finds a duplicate MAC_ID, it will go off-line and display the current MAC_ID on the diagnostics display. Use the Fault Reset button to decrement the MAC_ID to a new (unused) value. Hold the button in for 2 sec to program it permanently.

The NSD controller will now check for duplicate MAC_ID's using the new ID.

Network adjustable BAUD_RATE (default = 125Kb/s)

If your network runs at different baud rate, you can adjust the NSD controller using standard DeviceNet set commands. The NSD controller supports 125, 250, and 500Kb/s rates. After you change the Baud rate, you must cycle power to NSD to re-enable Devicenet.

Network settable CONNECTION (default= offline)

The NSD controller will allow EXPLICIT and BIT_STROBE connections only

Network adjustable EPR_RATE timer (default= 10sec for explicit connection, none for bit-strobe)

The EPR (Extendend packet rate) timer is set in 250msec increments. A value of less than 250 will keep the connection forever.

Bit_Strobe Return Values: (4 bytes returned)

BYTE 0: Status Code

Value	Definition
0	Off all mat
1	On at least one mat
5	Waiting for Fault Reset button to be pushed
6	Fault reset button held down
10-19	Mat fault codes
21-26	Relay fault codes
27-32	External relay fault codes
34	Ram failure
35	Power on reset
36	Clock / watchdog failure
37	Data exchange with Slave computer corrupted
38	Data exchange with Slave not completed

Byte 1: Zone Status

Definition:

0=relays off / contacts open;

1=relays on / contacts closed

Bit 7	Bit 6	Bit 5	Bit 4	Bit 3	Bit 2	Bit 1	Bit 0
Zone	Zone	Zone	Zone	Zone	Zone	Zone	Zone
#3	#2	#1					

Byte 2: Mat Status

Definition: 0=on mat; 1=off mat

Bit 7	Bit 6	Bit 5	Bit 4	Bit 3	Bit 2	Bit 1	Bit 0
Mat	Mat	Mat	Mat	Mat	Mat	Mat	Mat
#8	#7	#6	#5	#4	#3	#2	#1

Byte 3: Options Enabled

Definition: 0=disabled, 1=enabled

Bit 7	Bit 6	Bit 5	Bit 4	Bit 3	Bit 2	Bit 1	Bit 0
Re-served	Re-served	Re-served	Aux #2	Aux #1	Mute-out	Ext. Relay	Manual Reset
							Ckg.

Appendix "B"

Safety Guidelines for Management

Safety Guidelines for Management

Operational Safety

1. Appoint a Safety Coordinator to be responsible for safety regulations, requirements, and suggestions. He must review and investigate all accidents and "close calls."
2. Establish and issue safety rules. Inform each employee of his responsibilities. Make sure he understands them and knows what is expected of him.
3. A thorough review and an early inspection must be made of existing presses, dies, and point of operation guarding to attain the degree of responsibility required by ANSI B11.1-2001 Safety Standards and Federal State laws. Review what mandatory modifications are necessary.
4. Equipment that is no longer safe and that cannot be economically upgraded should be destroyed.
5. Never allow persons legally under age to operate or assist in the operation of machinery.
6. All personnel must be properly trained to eliminate accidents and injuries.
7. Regardless of the operator's experience, education, or language barrier, it is the responsibility of the supervisor to give him a thorough explanation with each new job assignment.
8. No employee should be given a work assignment that he does not fully understand. Only properly instructed and thoroughly trained personnel should be assigned to work on or with any machine.
9. It shall be the responsibility of the employer to provide an adequate, clean, safe, and uncluttered work area around each machine.
10. If a malfunction is reported, stop the machine immediately, correct the problem, then resume production.
11. Investigate all accidents and close calls. Analyze the reason for occurrence. Take action to prevent recurrence. Keep records of the investigation and preventative steps that were taken.
12. Only employees who understand the machines, operation and safety requirements, and who are able to communicate this knowledge should be given the responsibility of instructing and training others to perform as operators.
13. Management must decide that personnel protective safety equipment is required to perform each job safely. Items such as safety glasses, shoes, gloves, helmets, hand pads, spats, protective sleeves and material handling equipment are common in the metal working industry. If noise levels are excessive, protective headsets and earmuffs are recommended.

!!! CAUTION !!!

When a mat system is used to protect the operator or passerby from penetration, it must be mounted and properly sized so it is impossible to reach under, around, or over into the hazardous point of operation zone. Safety mat systems normally guard the front or feed area of a machine. The sides of the areas where the safety mat does not guard must be guarded by some other means or by additional safety mats.

If the position of the safety mat(s) will allow the operator or others to place themselves between the sensing field and the hazardous area, auxiliary guards or devices such as safety light curtains, barrier guards or devices should be used in conjunction with the safety mat(s) to prevent the operator or others from exposure to the hazardous area.

If mechanical guards such as: polyurethane, expanded or perforated metal, hairpins, etc., are used to guard these areas, the opening must comply with the OSHA safety distance in relationship to the openings.

After installation of point of operation guards and before a job is released for operation, a check should be made to verify that the guard will prevent the operators hands from reaching into the point of operation or any hazard zone. Always refer to the applicable OSHA & ANSI standard in order to assure proper compliance to the subject machine.

14. When designing point of operation guarding, the manufacturing process should be weighed heavily in favor of operational safety.
15. Establish safe and convenient material handling methods and procedures.
16. Post in convenient areas the names, addresses, and phone numbers of physicians and hospitals, and members of the organization who are to be called in case of emergency.
17. All equipment must be electrically connected according to the National Electric Code and be consistent with other accepted practices.
18. Provide adequate and proper fire protection equipment.

Safety Enforcement

In order to have an effective safety program, management at all levels must enforce every safety rule and regulation. Strong disciplinary measures are sometimes required. They should consist of a warning, written reprimand, work suspension, transfer, demotion, or possibly a dismissal. All infractions must be reported and recorded. Once an infraction is noted, it shows that an unsafe practice or condition has existed. This may be the result of poor planning or improper training and instructing. The reason for the infraction should be analyzed in order to take corrective action.

Supervisor Training

It should be the responsibility of management to instruct their supervisors on safety, giving job instructions, supervising operators, determining accident causes, and building safety attitudes among the machine operators. Accidents can occur due to inadequate training of supervisors.

Operator Training

It shall be the responsibility of management to insure proper training of operators. A specific training program should be instituted to instruct the operator in safety, proper usage of the equipment, and correct operational procedure in performing each and every job. In addition to the supervisor, the operator should be familiar with the proper guarding of the point of operation. Never permit an operator to start a job without complete instructions from his immediate supervisor.

WARRANTY

Manufacturer warrants that this product will be free from defects in material and workmanship for a period of one year from the date of shipment thereof. Within the warranty period, manufacturer will repair or replace such products which are returned to it with shipping charges prepaid and which will be disclosed as defective upon examination by the manufacturer. This warranty will not apply to any product which will have been subject to misuse, negligence, accident, restriction, and use not in accordance with manufacturer's instructions or which will have been altered or repaired by persons other than the authorized agent or employees of the manufacturer.

DISCLAIMER

The provisions of the paragraph "Warranty" are the sole obligations of the manufacturer and exclude all other warranties of merchantability, expressed or implied.

Further, there are no warranties which extend beyond the above warranty.

LIMITATION OF LIABILITY

In the event of any claim or breach of any obligations of manufacturer under any order, whether expressed or implied, and particularly in the event of any claim or a breach of the warranty or warranties contained in the paragraph "Warranty" or of any other warranties, expressed or implied which might, despite the paragraph entitled "Disclaimer," be determined to be incorporated in any order, the company shall under no circumstances be liable for any consequential or special damages, either in law or in equity, or for losses or expenses or claims for the same arising from the use of, or inability to use, the products of the manufacturer for any purpose whatsoever.

WARNING: The entire machine safety system must be tested at the start of every shift. Machine testing should include: (1) proper machine operation and stopping capability; and (2) verification of proper installation and settings of all point of operation guards and devices before the operation is released for production.



Sales and Marketing Offices

United States

Pinnacle Systems, Inc.

P.O. Box 100088

Pittsburgh, PA 15233

Toll Free Number: 800-569-7697

Direct Number: 412-262-3950

Fax: 412-262-4055

Canada

Pinnacle Systems, Inc.

8-1734 Orangebrook Court

Pickering, Ontario L1W 3G8

Toll Free Number: 888-285-8885

Direct Number: 905-831-1111

Fax: 905-831-4064

Customer Service: (630) 443-8542

We have designed our equipment to the very highest performance and safety standards known to the current technological state of the art, as evidenced by our U.S.A. and foreign patents issued and pending. However, the installation, usage, suitability, and fitness of our equipment for any purpose, known or unknown, is interdependent upon the performance of other equipment not manufactured, installed, secured or maintained by Pinnacle Systems, Inc.

We cannot and do not accept responsibility for any overall system performance when factors, such as these, are beyond our control.

www.pinnaclesystems.com

sales@pinnaclesystems.com
service@pinnaclesystems.com