

STTS

Safety Mat System™

Soft Tactile Transducer Sensor Safety Mat System for Robotics
and Hazardous Machinery Area Guarding

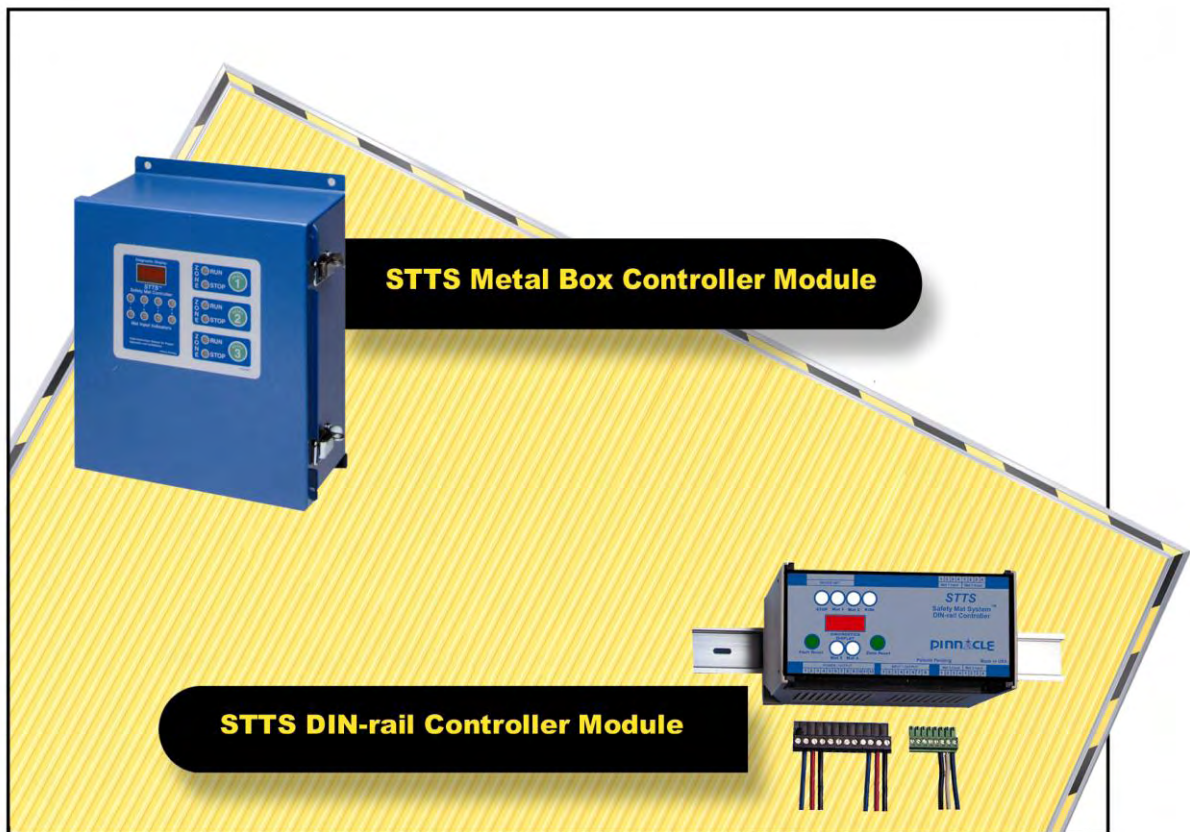

Installation Manual

PINNACLE
S Y S T E M S . I N C.

STTS

Safety Mat System™

INSTALLATION MANUAL

Pinnacle Systems, Inc.
3715 Swenson Avenue
St. Charles, IL 60174

P/N: 28-023r2-0

Customer Service: 630-443-8542

Sales and Marketing: 800-569-7697

www.pinnaclesystems.com • sales@pinnaclesystems.com • service@pinnaclesystems.com

Proper Use and Limitations

The information disclosed herein includes proprietary rights of the manufacturer. Neither this document nor the information disclosed herein shall be reproduced or transferred to other documents, used or disclosed to others for manufacturing purposes, or for any other purposes, except as specifically authorized in writing by the manufacturer. If this manual is supplied in connection with the sale or delivery of manufacturer's equipment, it is to be used solely for maintenance, repair, or installation of such equipment.

The STTS was manufactured in the United States. The Installation Manual was printed in the United States.

You must read and fully understand the following information pertaining to the proper use and limitations of your STTS:

- The STTS must be installed by qualified personnel only.
- The STTS must NOT be used on full revolution presses or any machine that cannot be commanded to stop at any time.
- You must NOT wire the Safety Output contacts of the STTS to an external relay unless you use the External Relay Checking feature.
- The mechanical power press on which the STTS is installed must meet ANSI B11.1-2001 and OSHA 1910.217 regulations. These include inspection and maintenance procedures that must be followed to comply with the regulations. The manufacturer will NOT take responsibility for improperly maintained machinery.
- Point of operation safeguarding is defined in ANSI B11.19-2003. This regulation is used to determine a safe distance to place your STTS. The manufacturer takes no responsibility for injury as a result of improper safeguarding or improper safe distances.
- The STTS may not be able to safely stop a press which has a faulty stopping mechanism. The manufacturer cannot be held responsible for an improperly maintained or faulty stopping mechanism.
- The STTS must be checked before put into operation. Follow instructions provided in this manual for procedures on how to do this.
- The STTS should never be modified or repaired except by qualified personnel and upon authorization of the manufacturer. Never operate machinery that is not in full working order.
- Make sure that all maintenance people, machine operators, die-setters, foreman, and supervisors have read and understood this manual and all procedures have been and will be followed.
- All procedures in this manual must be followed. The manufacturer cannot take responsibility for operation if all procedures and warnings in this manual are not followed.

Warranty

Manufacturer warrants that this product will be free from defects in material and workmanship for a period of 2 years from the date of shipment thereof. Within the warranty period, manufacturer will repair or replace such products which are returned with shipping charges prepaid and which will be disclosed as defective upon examination by the manufacturer. This warranty will not apply to any product which will have been subject to misuse, negligence, accident, restriction, and use not in accordance with manufacturer's instructions or which will have been altered or repaired by persons other than the authorized agent or employees of the manufacturer.

DISCLAIMER

The provisions of the paragraph "WARRANTY" are the sole obligations of the manufacturer and exclude all other warranties of merchantability, expressed or implied. Further, there are no warranties which extend beyond the above warranty.

LIMITATION OF LIABILITY

In the event of any claim for breach of any obligations of manufacturer under any order, whether expressed or implied, and particularly in the event of any claim of a breach of the warranty or warranties contained in the paragraph "WARRANTY" or of any other warranties, expressed or implied, which might despite the paragraph entitled "DISCLAIMER," be determined to be incorporated in any order, the company shall, under no circumstances, be liable for any consequential or special damages, either in law or in equity, or for losses or expenses or claims for the same arising from the use of, or inability to use, the products of the manufacturer for any purpose whatsoever.

We have designed our equipment to the very highest performance and safety standards known to the current technological state of the art. However, the installation, usage, suitability, and fitness of our equipment for any purpose, known or unknown, is interdependent upon the performance of other equipment not manufactured, installed, secured, or maintained by Pinnacle Systems, Inc.

We cannot and do not accept responsibility for any overall system performance when factors, such as these, are beyond our control.

WARNING: The entire machine safety system must be tested at the start of every shift. Machine testing should include: (1) proper machine operation and stopping capability; and (2) verification of proper installation and settings of all point of operation guards and devices before the operation is released for production.

WARNING

This installation manual must be read in full prior to any installation work being started.

TABLE OF CONTENTS

| | |
|---|-------|
| Proper Use and Limitations | i |
| Warranty | i |
| System Overview | 1 |
| Circuit Description | 1 |
| Technical Specifications | |
| Metal Box Controller..... | 2 |
| DIN-rail Controller..... | 3 |
| DeviceNet..... | 20 |
| Setup and Installation | |
| <i>Metal Box Controller</i> | |
| Installation..... | 4 |
| Control Setup..... | 5 |
| Operation Guide..... | 6 |
| Jumper Settings..... | 7 |
| Accessible Connections..... | 9 |
| Computer Board Connector / Jumper Layout..... | 11 |
| Power Supply Board Connector Layout..... | 12 |
| Wiring Diagram for Mat(s)..... | 14 |
| Wiring Diagram for Zone(s) (outputs)..... | 15 |
| Dimensions..... | 18 |
| <i>DIN-rail Controller</i> | |
| Installation..... | 4 |
| Control Setup..... | 5 |
| Operation Guide..... | 6 |
| Jumper Settings..... | 8 |
| Accessible Connections..... | 10 |
| Board Connector / Jumper Layout..... | 13 |
| Wiring Diagram for Mat(s) and Zone..... | 16 |
| Remote Status Display..... | 17 |
| Dimensions..... | 19 |
| Diagnostics and Troubleshooting (for both controllers) | |
| Display Codes and Messages..... | 21-22 |
| Guidelines and Regulations for Safe Operation (for both controllers) | |
| Safety Evaluation..... | 23 |
| Maintenance..... | 24 |
| Annex A (Mat + per pfEN999)..... | 25 |
| Annex B (informative)..... | 26 |
| Annex C (Installation Practices for Industry)..... | 27-28 |
| Annex D (Replacement Part Listing)..... | 29 |

WARNING

“Categories in accordance with EN 954-1 for pressure sensitive mats and pressure sensitive floors on machines are stated in type “C” standards.

This installation manual is written in English language only. Installation of this equipment must be done by qualified personnel with fluent English language understanding skills.

All “CE” marked products for the European Community must be 24VDC input power.

SYSTEM OVERVIEW

Together with a new patented mat technology, eliminating internal metal plates, and the STTS control using diverse redundant technology, Pinnacle Systems has achieved a system compliant with OSHA, ANSI, and the European standards EN954-1 & EN1760-1. These standards dictate safety of machinery-related parts of control systems and pressure deflection sensitive protective devices and focus on creating a fault tolerant system. All safety related faults cause a lockout condition requiring internal reset.

The STTS Metal Box Controller system can be ordered with 1 to 3 separate output zones, each with 3 separate isolated dry contact outputs and user option external relay checking for each zone. Up to 8 separate mat inputs allow any combination of mats to control any combination of zones and at the same time provide instant information of mat faults via a scrolling diagnostic message display and LED's. DEVICENET industrial data network is optionally available.

In addition to the above-mentioned compliance with various standards, the STTS DIN-rail controller has been evaluated and approved by the CSA (for electrical safety only). The STTS Din-Rail controller system comes standard with 1 output zone (2 safety relays, 1 form C auxiliary relay, and 1 fault relay), external relays checking, and inputs for up to 4 mats. Diagnostic messages are the same as the metal box, but the din-rail allows for an optional remote diagnostics display. DEVICENET industrial data network is optionally available.

CIRCUIT DESCRIPTION

Low voltage DC signal (+20VDC & -20VDC) is pulsed out to the mat through two wires. The wires attach to the top and bottom (internally) of the mat and any force on the mat lowers the resistance between the two wires causing a drop in voltage. A second pair of wires coming back from the mat is used to sense this drop in voltage. The redundant circuits compare the voltage to a reference and shut down the zone when the voltage drops below the reference. The circuit goes through a self-check to verify that the reference, comparators, mat, wiring, and other circuits are all functioning normally every time it scans a mat input. Diverse redundant technology, provided by two different computers, controls the whole system and allows more system flexibility (i.e., diagnostic message display).

METAL BOX CONTROLLER

POWER SUPPLY BOARD

This system is capable of running off of 120VAC or 240VAC or 24VDC input and contains the circuitry for up to 3 zones (a total of 9 force-guided contact relays) and external relay checking. This board is connected to the computer board via a 34 pin plug-in header (J6).

COMPUTER BOARD

This board contains two computers, circuitry for eight separate mat inputs, connectors for diagnostics display, LED's, and push-buttons.

DISPLAY BOARD

This board contains the Diagnostics display, mat input LED's, and zone output LED's.

DIN-RAIL CONTROLLER

The Din-Rail controller is actually 1 circuit board broken up into 3 boards. All 3 boards are linked via right angle connectors. The Power input is strictly 24vdc as well as all other inputs. Outputs come from 4 relays that provide dry contacts up to 30vdc.

TECHNICAL SPECIFICATIONS (Metal box controller)

Power: 18 - 28VDC @ 18 Watts Optional, requires removal of transformer.
 (3 zones) 85-125VAC @ 19 VA All AC voltages work with 50 or 60 Hz
 200-245VAC @ 19 VA Jumper change required

Max # of Mats: Up to 8 separate mat inputs

Total Response Time: 35 mSec/mat input

Outputs: *Safety:* 2 N.O. outputs (open when RED) per zone 8A@250vac resistive
Auxiliary: 1 N.O. or N.C. output per zone 8A@250vac resistive
Fault: 1 N.O. (open when faulted) 5A@250vac resistive

NOTE: Relay current rating is de-rated by 1/2 for inductive loads and again by 1/2 for temperatures approaching 50C

Zone Reset Inputs: 3 inputs for N.O. push-buttons for manual resetting of each zone (Green buttons on front panel). J11 and J12 located on computer board (either one can be used for remote resetting)

Settings: Jumpers to select manual or automatic reset, # of mats / zones and how many zones, fault reset, and external relay checking. (S1, S5 and JP6)

Indicators:

Internal: Red LED on power supply board ON = +12V supply ok
 Green LEDs on computer board 5v and 20V supply ok

External: 8 Yellow LED's (1 per mat input) Yellow LED on = standing on mat
 Yellow LED flashing = Fault with mat/circuitry
 3 Red/Green LED's (1 set per zone) on panel door Green LED on = Relays energized
 Red LED on = Relays de-energized
 Red LED flashing = Relay fault

| DESCRIPTION | DIMENSIONS | MOUNTING HOLE |
|---|---------------------------|------------------|
| Computer board | 6.50" x 8.00" | 6.00" x 7.50" |
| | 165.1 x 203.2 mm | 152.4 x 190.5 mm |
| Power supply board | 6.50" x 8.00" | 6.00" x 7.50" |
| | 165.1 x 20,32 mm | 152.4 x 190.5 mm |
| Display board | 4.00" x 5.75" | 3.50" x 5.00" |
| | 101.6 x 14,60 mm | 88.9 x 127.0 mm |
| Mounting plate (used for short stack only) | 8.87" x 8.87" | 8.00" x 8.00" |
| | 225.4 x 22,54 mm | 203.2 x 203.2 mm |
| Control Box | 10.00"H x 9.00"W x 5.25"D | 7.75" x 10.75" |
| | 254H x 228.6W x 133.3D mm | 196.8 x 273.0 mm |

Tolerance: +/- 0.10 inches / 02.5 cm

Environmental: 0 to 50C

TECHNICAL SPECIFICATIONS (Din-Rail controller)

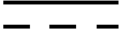
Power:  24VDC +/- 15% @ 7 Watts maximum

Fuse Rating: F1: 1A fuse

Max # of Mats: Up to 4 separate mat inputs

Total Response Time: 35 mSec/mat input

Outputs: *Safety:* 2 N.O. outputs (open when RED) 5A@30vdc resistive
Auxiliary: N.O. or N.C. with common 5A@30vdc resistive
Fault: N.O. (open when fault or no power) 5A@30vdc resistive

NOTE: Relay current rating is de-rated by ½ for inductive loads and again by ½ for temperatures approaching 50C

Zone Reset Inputs: 1 input for N.O. push button for manual resetting located on front of DIN-rail Controller or optional Remote Status Display (RSD)

Settings: Jumpers to select manual or automatic reset, up to four mats, fault reset, and external relay checking

Indicators:

Internal: +5V – Yellow LED's (1) Relays – Green LED's (4)
+12V – Red LED (1) 20v – Green LED (1)

External: 4 Yellow LED's (1 per mat input) Yellow LED on = standing on mat
Yellow LED flashing = Fault with mat/circuitry

Red/Green LED's Green LED on = Relays energized
Red LED on = Relays de-energized
Red LED flashing = Relay fault

Dimensions: Overall: 5.9" length x 2.9" wide x 4.3" height

DIN-rail: 35mm

Tolerance: +/- 0.10 inches / 02.5 cm

Environmental: 0 to 50C
Installation category I
Pollution degree 2
Altitude: up to 2000 meters
Humidity of 80% up to 31° C decreasing linearly to 50% humidity at 40° C
Indoor use

No cleaning is required.



The unit shall be supplied by a SELV source in accordance with CSA 1010.1 Annex H

INSTALLATION

WARNING: The entire machine safety system must be tested at the start of every shift. Machine testing should include: (1) proper machine operation and stopping capability; and (2) verification of proper installation and settings of all point of operation guards and devices before the operation is released for production.

The STTS mat system has been designed to promote individual mat "homerun" wiring back to the mat controller. This is suggested for easing installation and diagnostics for maintenance troubleshooting. This will also eliminate cumbersome "daisy chain" wiring practices of mat systems. It also eliminates numerous wiring connection points buried under the perimeter trim, which are time intensive to troubleshoot.



INSTALLATION

- 1) Sweep the floor area where the safety mat is to be installed. The floor should be flat and free of foreign material.
- 2) Locate the safety mat in the desired location. For future reference, install the mat with the label side up.
- 3) Slide the black wire raceway component under the mat edge (Part #M002). Refer to the graphic below for proper component positioning. NOTE: The wire raceway component must be installed whenever the surface perimeter trim component is used.
- 4) Route the wire/plug assembly on the raceway toward the mat controller location.
- 5) Lay the aluminum perimeter trim piece around the mat assembly. Determine where the mat wiring will exit the trim and notch the trim and wire raceway for the wire to exit the assembly.
- 6) If surface metal raceway is used to route the wiring (Part #M005 or M006) from the mat assembly across the floor toward the mat controller, it should be aligned with the notch in the perimeter trim and anchored to the floor. Route wires accordingly and snap cover plate over the wires.
- 7) Slide the perimeter trim over the wire raceway component and align over the mat edge per Figure 1. Drill the perimeter trim and floor for securing the perimeter trim to the floor with anchoring screws and floor anchors.
- 8) If a multiple mat assembly is to be installed, use the aluminum active coupler component (Part #M003) to connect mats end-to-end or side-to-side. Refer to graphic below.

Cross Section View of Mat Assembly Active Edging

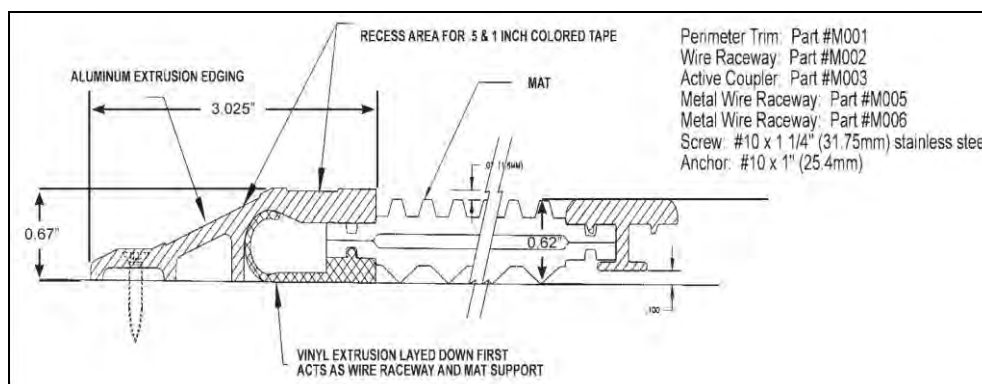

CONTROL SETUP

Choose number of mat(s) per zone (metal box controller only):

Zone 1 mats must start at Mat input #1 and work up. Zone 2 mats must start at the next available mat input, and so on. The S5 jumper block is used to program the number of mats per zone (see "User Configuration Jumpers").

NOTE: The total number of zones your STTS controller has was determined at the time of order placement and is from 1 to 3. If you need to increase the number of zones at a later date, the unit will need to be shipped back to the place of purchase for an upgrade.

| | |
|--|---------------------------------------|
|  | STTS Safety Mat System |
| P.O. Box 100088 Pittsburgh, PA 15233 800-569-7697 FAX: 412-262-4055 www.pinnaclesystems.com | |
| Model: A-3-2-1-2 | Response Time: <30mSec |
| Part: Controller | Selectable Reset: |
| Input Power: 24VDC | Manual/Automatic |
| Contact Rating: 8A @ 24VDC Res. | |
| Safety Rating: EN954-1 Category 3+ | |
| Environmental Rating: NEMA 12 (IP54) | |
| Temperature Rating: 0° to 50° C | |
| Made in USA | |

Choose your options:

You may select manual or automatic zone resetting (see "User Configuration Jumpers").

MANUAL: If you select manual, you will have to go to the control box and press the zone reset button each and every time you step on any mat(s) Metal box: Place jumper across JP6 MAN on the top board. Din-Rail: Place jumper across JP3 MANUAL

AUTOMATIC: If you select automatic, the zone will clear itself when you have stepped off the mat(s).
Metal Box: Remove jumper across JP6 MAN on the top board.
Din-Rail: Remove jumper across JP3 MANUAL.

NOTE: This setting changes all mats, you cannot change some mats to manual and some to automatic.

EXTERNAL RELAY CHECKING: External relay checking option is selected when you have to switch a large load. This feature allows the STTS to monitor your external relays. This system requires that you use two force-guided relays for the external switching and that the secondary pole of each relay (N.C.) be tied in series back to the STTS control external relay input terminals for each particular zone
Metal Box: Place jumper across JP6 EXT on the top board to activate this feature.
Din-Rail: Place jumper across JP4 EXT to activate this feature.

Metal box mounting location:

After choosing an appropriate location you will need to remove the computer board and the power supply board from the box in order to punch two holes—one for the power lines and the other for mat wiring. See "Wiring Diagram for Mats" and "Wiring Diagram for Zones" for wiring hookups.

HOOKUP POWER AND ZONE STOP CIRCUITS TO POWER SUPPLY BOARD:

- 1) Attach power lines to J3 PLUG (LINE, NEUTRAL, GROUND). Line and Neutral are un-polarized for DC use.
- 2) Attach stop circuit to terminals 1 & 4 of J5 for Zone 1, terminals 10 & 13 for Zone 2, terminals 19 & 22 for Zone 3.
- 3) Attach auxiliary circuit to terminals 5,6,7 for Zone 1, terminals 14,15,16 for Zone 2, terminals 23,24,25 for Zone 3.
- 4) Attach External Relay Checking input wires to terminals 8,9 for Zone 1, terminals 17, 18 for Zone 2, terminals 26,27 for Zone 3.

Din-Rail controller:

The controller must be mounted inside an enclosure since all the wiring terminates on the outside of the controller box.

- 1) Attach 24vdc power, and stop circuit(s) to the POWER/OUTPUT plug
- 2) Hook up mats to the mat # plugs.
- 3) Hook up options to the INPUT/OUTPUT plug

OPERATION GUIDE

At power-up the control will go through a test and then, if manual reset option is enabled you must reset the zone. If automatic reset is enabled, the unit will activate each zone that passes the test and nothing is found on the mat(s).

WHEN YOU STEP ON THE MAT:

The corresponding yellow mat input LED will turn on and, at the same time, the green zone LED will turn off and the red zone LED will turn on. All three relays related to this zone will de-energize and open up the N.O. outputs.

WHEN YOU STEP OFF THE MAT:

The corresponding condition of the LED's described above will reverse. All three relays related to this zone will energize and close the N.O. outputs

GETTING FAULT CODES:

The yellow mat input LED corresponding to the mat fault will flash to indicate which mat input circuit or mat is faulting. All available zones will shut down and de-energize all relays. When 1 zone has a fault, all zones shut down.

Problem: NO FAULT CODES DISPLAYED, BUT THE ZONE WILL NOT CLEAR
(No Green LED, but a Yellow LED is lit)

Cause: 1) Manual reset button needs to be pushed.
2) Something is on the mat, or the trim around the mat is too tight.
3) Mat failure (short in the wiring or the mat itself)

Cure: 1) Try swapping the mat with another mat to verify this failure.
2) Call for assistance.

JUMPER SETTINGS (metal box controller)

Computer Board:

S5
BOTTOM

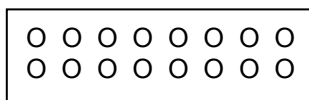

TOP

1 2 3 4 5 6 7 8

| SHUNT(S) | DEFINITION | USAGE (1= JUMPER ON PINS) |
|----------|---------------------|---|
| 1,2,3 | # of mats in zone 1 | 1 MAT = 0,0,0 2 MATS = 1,0,0 3 MATS = 0,1,0 4 MATS = 1,1,0 5 MATS = 0,0,1 6 MATS = 1,0,1 7 MATS = 0,1,1 8 MATS = 1,1,1 |
| 4,5,6 | # of mats in zone 2 | 0 MAT = 0,0,0 1 MAT = 1,0,0 2 MATS = 0,1,0 3 MATS = 1,1,0 4 MATS = 0,0,1 5 MATS = 1,0,1 6 MATS = 0,1,1 7 MATS = 1,1,1 |
| 7,8 | # of mats in zone 3 | 0 MAT = 0,0 1 MAT = 1,0 2 MATS = 0,1 3 MAT = 1,1 |

Computer Board:

AUX
EXT
MAN

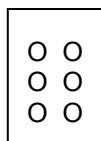

S1



| SHUNT(S) | DEFINITION | USAGE |
|----------|--|--|
| S1 | Fault reset (Push Button) | Resets fault codes (tries to re-initialize unit) |
| JP6-AUX | N/A | Not used at this time |
| JP6-EXT | External relay checking active for all zones used E=Ext. relay checking | Apply jumper to activate function (message display will add an E (ok E) to indicate you have selected this function) |
| JP6-MAN | Manual / Automatic reset for all zones M = Manual reset | Jumper forces manual push-button to re-energize zone relays (message display will add an M (ok M) to indicate you have selected this function) |

JUMPER SETTINGS (Din-Rail controller)

1= jumper install

Number of Mats:

JP2 JP1

| | | |
|---|---|--------|
| 0 | 0 | 1 mat |
| 1 | 0 | 2 mats |
| 0 | 1 | 3 mats |
| 1 | 1 | 4 mats |

JP3

1= Manual relay resetting
0= Automatic relay resetting

JP4

1= External relay checking enabled
0= Disabled

JP5

Not used at this time

JP6

Not used at this time

ACCESSIBLE CONNECTIONS (Metal box controller)

Computer board:

J9 Diagnostics display plug
 J10 Connection to Power supply / Relay board
 J17 Mat fault and Zone fault lights plug
 J11 Push-button zone reset plug (N.O.)

J12 Remote push-button zone reset plug (N.O.)

| Terminal No. | Function | Usage |
|--------------|----------|--|
| GND | Ground | For zone LED's |
| 1,2,3 | 1,2,3 | short to ground pin to reset zone in manual mode |

J13 DEVICENET PLUG

| Terminal No. | Usage |
|--------------|-------------------------|
| GND | Ground |
| CANH,CANL | Twisted pair data lines |

J1,J2,J3,J4,J5,J6,J7,J8 Mat input terminals (1 to 8)

| Terminals No. | Usage |
|---------------|--|
| 1,2 | Return from mat (1=blue, 2=white) |
| 3,4 | 20vdc Output to mat (3=black, 4=brown) |

NOTE: Canadian market wiring is black, red, red, black with 18-gauge wiring size.

Power Supply Board:

J3 Power input (removable plug)

| Terminals No. | Usage |
|---------------|-------------------------------------|
| 1 | Earth Ground |
| 2 | Neutral (ground for DC controllers) |
| 3 | Line (+24vdc for DC controllers) |

J7 Fault relay output (removable plug)

| Terminals No. | Usage |
|---------------|--|
| N.O. | Opens when a fault occurs (or power off) |
| C. | Common for the relay |
| N.C. | Closes when a fault occurs |

J6,J13,J14 Relay outputs, external relay inputs (removable plug)

| Terminal No. | Usage |
|--------------|--|
| 1,2 | Safety relay N.O. output (dry contact) |
| 3,4 | Safety relay N.O. output (dry contact) |
| 5,6,7 | Auxiliary relay N.C., COM, N.O. |
| 8,9 | External relay checking option 120V ac applied across these terminals when external relay is de-energized |

N.O. Normally Open COM. = Common N.C. = Normally Closed

ACCESSIBLE CONNECTIONS (Din-Rail controller)

Internal:

J1 Diagnostics display plug (used by remote status display option)
 The Plug is located under the top cover on the left side of the controller

External:

POWER/OUTPUT PLUG

| Terminal No. | Usage |
|--------------|--|
| 1,2,3 | +POS, -NEG, EARTH GROUND (24VDC ONLY) |
| 4,5 | Safety relay N.O. output (dry contact) |
| 6,7 | Safety relay N.O. output (dry contact) |
| 8,9,10 | Auxiliary relay N.C., COM, N.O. |
| 11,12 | Fault relay N.O. (open when faulted) |

INPUT / OUTPUT PLUG

| Terminal No. | Usage |
|--------------|---|
| 1,2 | +pos, -neg External relay checking (option) 24vdc applied across these terminals when external relay is de-energized |
| 3 | Remote external zone reset (Ground to reset zone) |
| 4,5 | Auxiliary inputs (Ground to activate feature) |
| 6 | +24vdc input (Common for terminals 3,4,5) (jumper from term #1 Power/Output) |
| 7 | Optional remote RED "STOP" indicator output (Grounded when RED) |
| 8 | Optional remote GREEN "RUN" indicator output (Grounded when GREEN) |

MAT 1,2,3,4 INPUT

| Terminal No. | Usage |
|--------------|---|
| 1,2 | 20VDC output to mat (1=blue, 2=white) voltage between 1 & 2 alternates |
| 3,4 | Return from mat (3=black, 4=brown) |

NOTE: Canadian market wiring is black, red, red, black with 18-guage wiring size.

DEVICENET PLUG (DB-9 female)

| Terminal No. | Usage |
|--------------|--------------------------------------|
| 2,7 | CANL, CANH (twisted pair data lines) |
| 3,6 | Ground |

BOARD CONNECTOR LAYOUT

DIN-rail Controller

| | | | |
|--------|---------------------------------|-------|--------------------------|
| J2,J26 | MAT INPUT #1 thru #4 | JP1,2 | NUMBER OF MATS SELECTION |
| J1 | DIAGNOSTICS DISPLAY (remote) | JP3 | MANUAL |
| J120 | POWER/OUTPUT | JP4-6 | EXT, AUX1, AUX2 |
| D13,14 | Safety relay output on (closed) | D3 | +12v supply |
| D16 | Auxiliary relay output on | D1 | +5v supply |
| D15 | Fault relay output on (closed) | D23 | +20v supply |

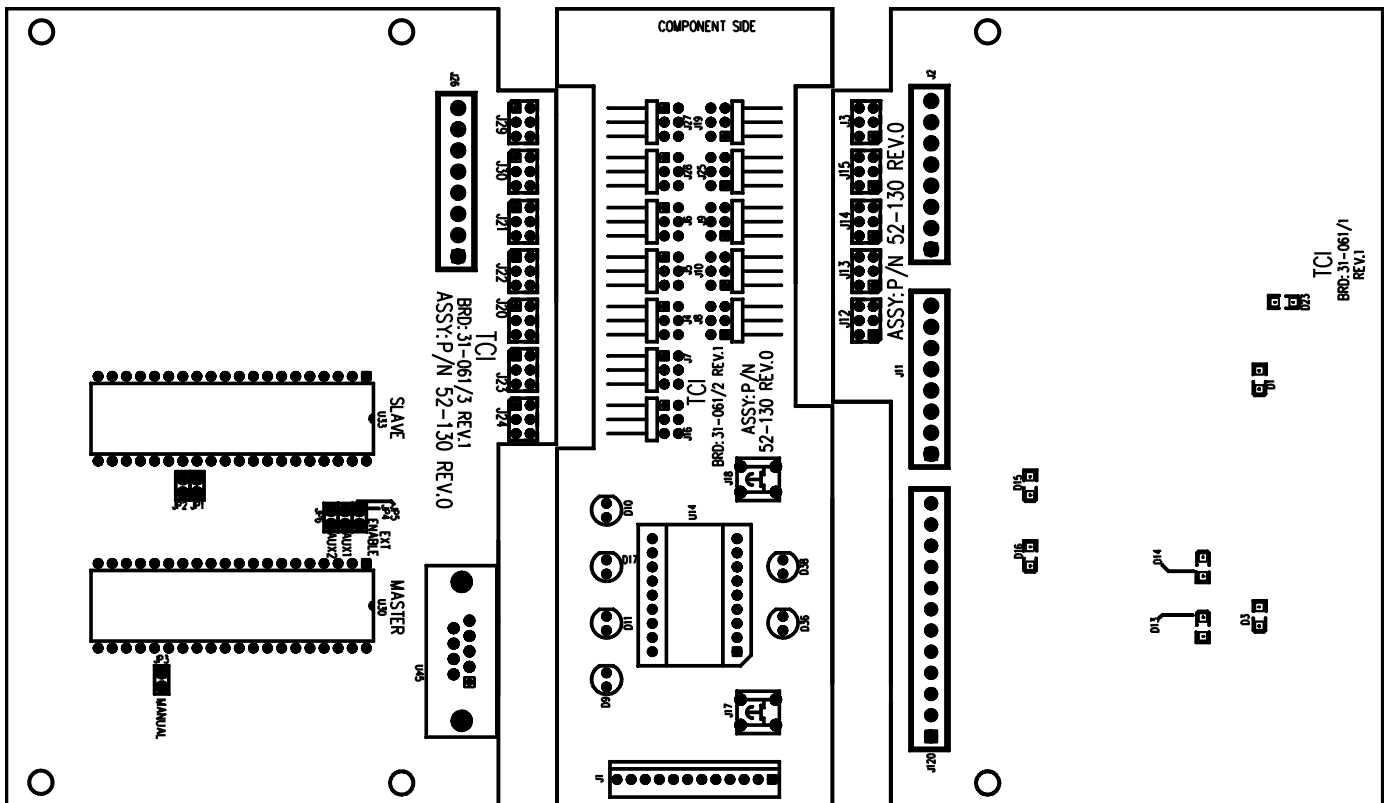

WIRING DIAGRAM FOR MAT(S)

Metal Box Controller

This example is for two mats. Each additional mat gets its own input (up to 8 on an input board). Follow the color code from each mat back to the STTS control box.

NOTE: Adjust the S5 jumper block when adding / deleting mats and zones.

NOTE: The manual/automatic reset feature sets all mats. You cannot select some mats for manual and some for automatic.

NOTE: Canadian market wiring is black, red, red, black with 18-gauge wiring size.

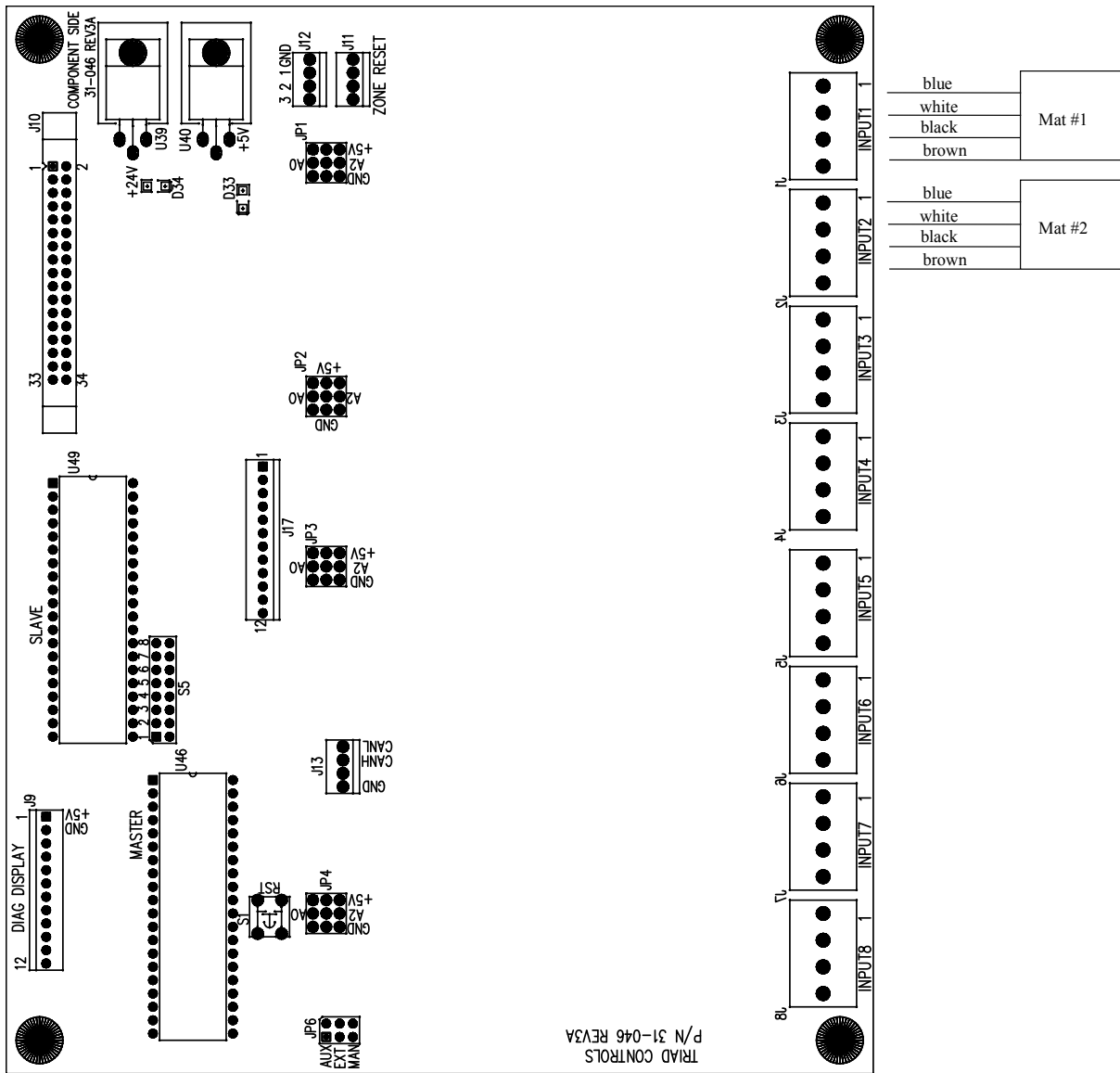

WIRING DIAGRAM FOR ZONE(S) (OUTPUTS)

Metal Box Controller

The following examples show two ways to wire a zone: Zone #1 is wired the standard method; Zone #2 is wired for use with external relays. Either of these methods can be applied to any zone.

NOTE: If you use external relays, you must use them on all available zones. You cannot have external relays on one zone and not on the other zone.

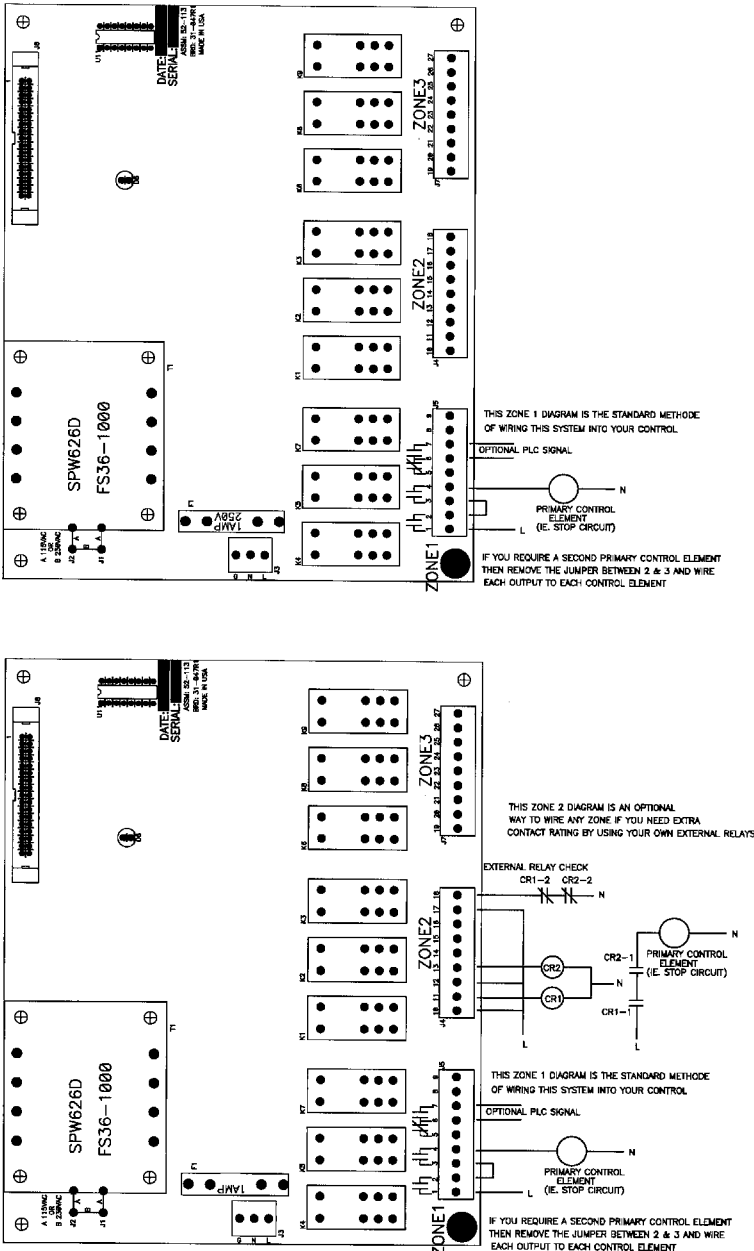

Knock out two holes in bottom section of metal box housing for input power wiring and alarm zone wiring; minimum hole size of 1/2" (13mm). Care should be exercised in protection of the conductors from abrasion where they enter the controller box, with conduit it is accomplished by bushings or other approved devices. With NM cable, the outer covering of the cable should protrude from the clamp to provide this protection. With armored cable, fiber bushings are to be inserted between the conductors and the armor to prevent any abrasion. All fittings and connectors shall maintain a NEMA 12 (IP 54) rating at a minimum.

A. Openings to be closed-where conductors enter any openings, they shall be properly closed.

B. When conduit or fittings are used with open wiring, proper bushings shall be used.

NOTE: If you require 24VDC for power, the transformer SPW626D will be replaced with two chokes. This modification cannot be performed in the field on the board itself, it must be done at the factory. All "CE" marked products for the European Community must be 24VDC input power.

WIRING DIAGRAM FOR MAT(S)

DIN-rail Controller

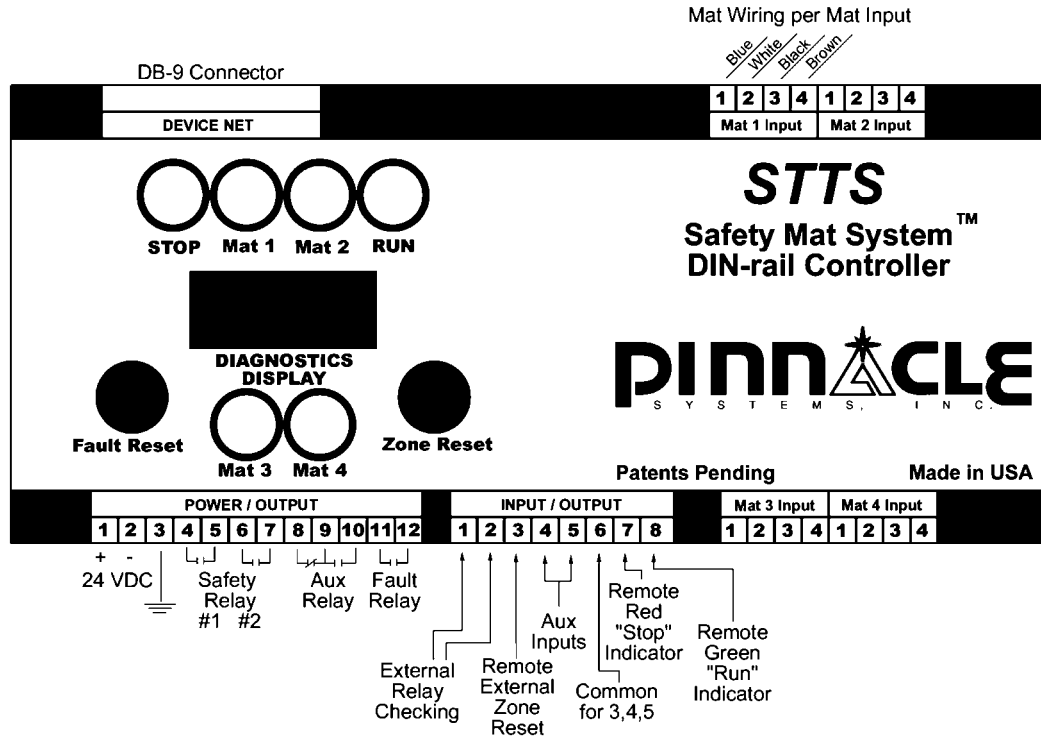

NOTE: Canadian market wiring is black, red, red, black with 18-gauge wiring size.

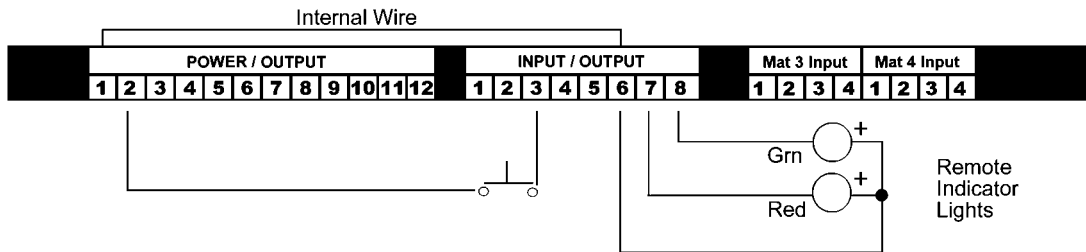

External Relay Checking (optional usage)

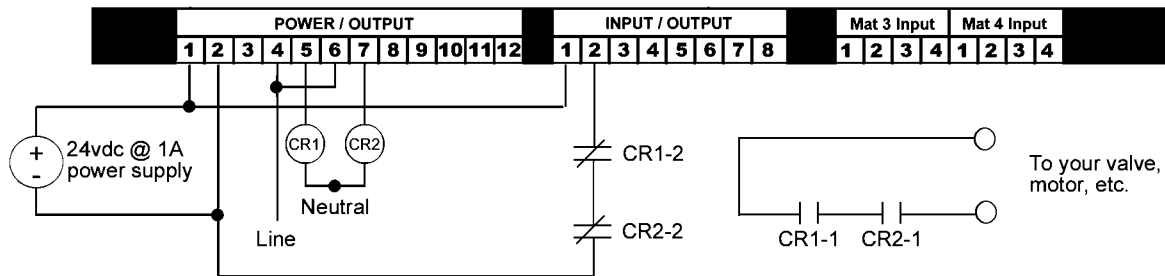

Remote Status Display

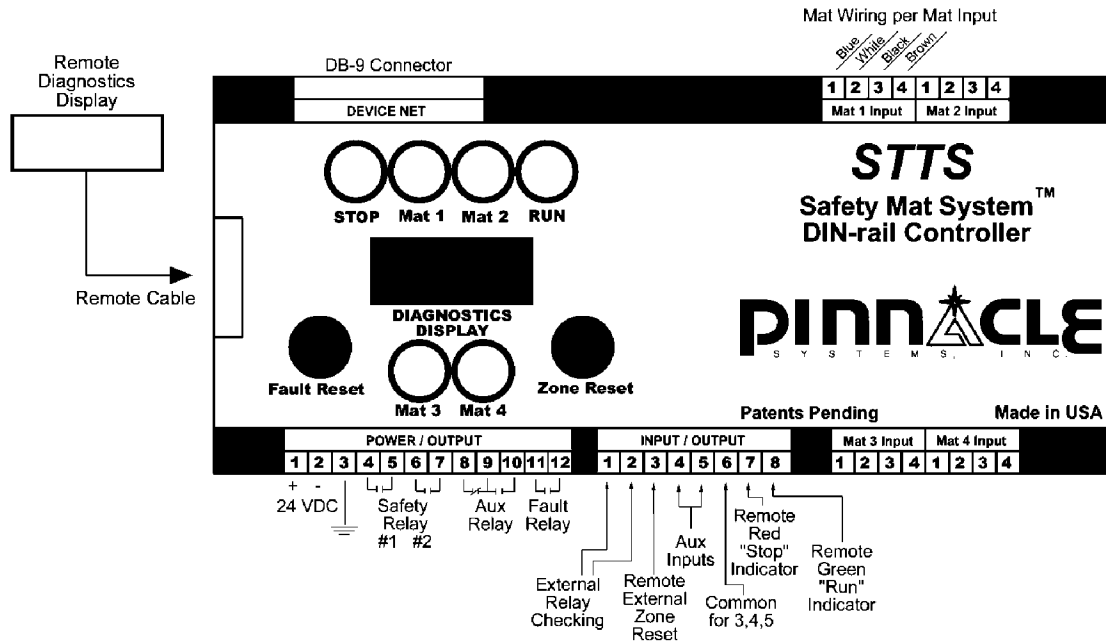

NOTE: Canadian market wiring is black, red, red, black with 18-gauge wiring size.

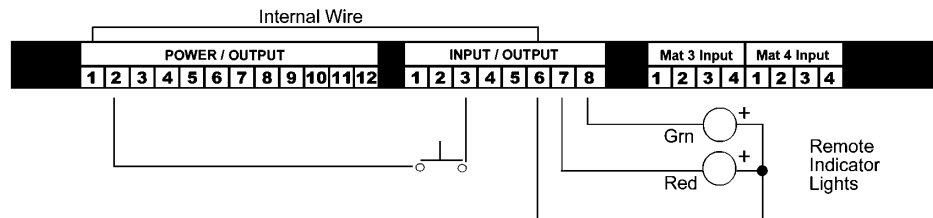

NOTE:

Terminal #6 (INPUT/OUTPUT PLUG) is internally connected to Terminal #1 (POWER/OUTPUT) plug. This allows Terminal #6 to provide +24v to the lights for the RSD (Remote Status Display).

REMOTE STATUS DISPLAY

- Green: Terminal #8 (INPUT/OUTPUT)
- Red: Terminal #7 (INPUT/OUTPUT)
- Black: Terminal #1 (POWER/OUTPUT)
- White/Black: Terminal #3 (INPUT/OUTPUT) / Terminal #2 (POWER/OUTPUT)
- 12cond cable: J1 (on left side of diagnostics display)

DIMENSIONS (Metal box controller)

| Dim "A" | Dim "B" | Dim "C" | Dim "D" | Dim "E" | Dim "F" |
|----------|----------|----------|----------|----------|----------|
| 9.00" | 7.75" | 10.00" | 5.25" | 10.75" | 11.50" |
| 228.6 mm | 196.8 mm | 254.0 mm | 133.3 mm | 273.0 mm | 292.1 mm |

Tolerance: +/- 0.10 inches / 02.5 cm

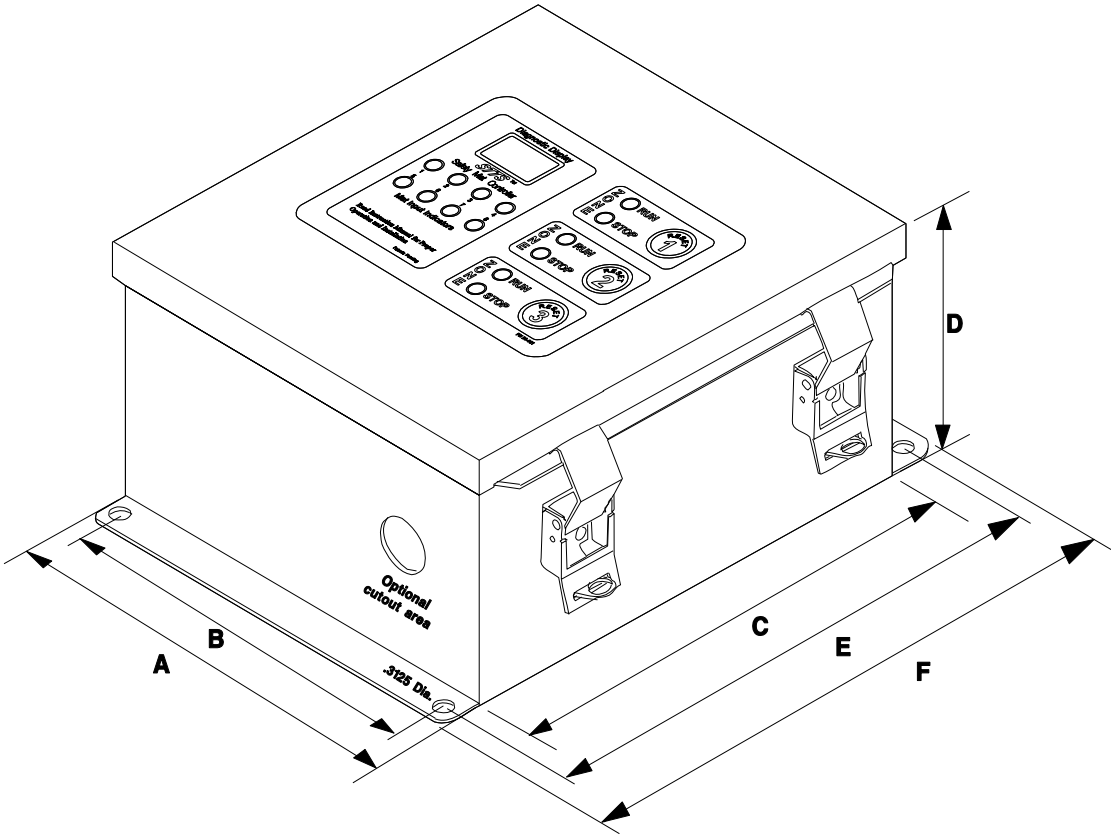

DIMENSIONS (Din-Rail controller)

The DIN-rail Controller can be either DIN-rail mounted or screwed down. Be sure to allow space for wiring to top of box (both sides).

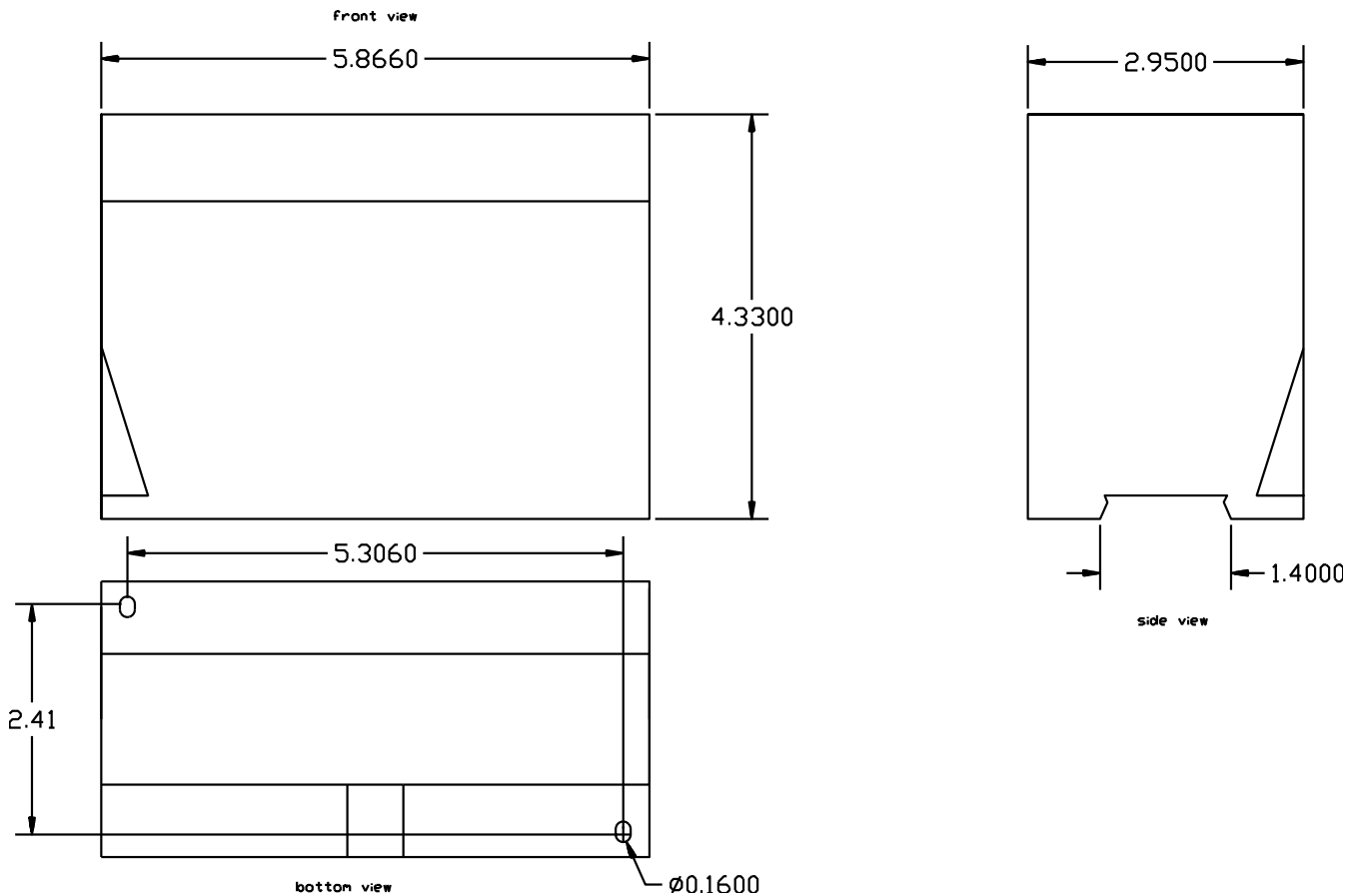

- Enclosure:** Gray polycarbonate with clear cover. Provides IP40, UL94V-1
- Enclosure Dimensions:** 5.87" (149 mm) length x 4.33" (110 mm) depth x 2.95" (75 mm) height
- Enclosure Mounting:** 35 mm DIN-rail mountable
or
Mounting screws on corners of enclosure requiring two combo-head screws (3.5 x 0.6 mm x 14 mm or #6 x .5)

DEVICENET SPECIFICATIONS

Vendor ID code = 0459

Diagnostics Display:

- “OK U” DeviceNet unconnected (maybe unplugged from network)
- “OK C” DeviceNet connected but not allocated (passed duplicated mac id check)
- “OK A” DeviceNet allocated (in service)
- “OK F” DeviceNet faulted out (mat controller will work, but not DeviceNet)

User adjustable MAC_ID: (default = 63)

If the STTS controller finds a duplicate MAC_ID it will go off-line and display the current MAC_ID on the diagnostics display. Use the Fault Reset button to decrement the MAC_ID to a new (unused) value. Hold the button in for 2 sec to program it permanently.

The STTS controller will now check for duplicate MAC_ID's using the new ID.

Network adjustable BAUD_RATE: (default = 125Kb/s)

If your network runs at different baud rate, you can adjust the STTS controller using standard DEVICENET set commands. The STTS controller supports 125, 250, and 500Kb/s rates. After you change the Baud rate, you must cycle power to STTS to re-enable DeviceNet.

Network settable CONNECTION: (default= offline)

The STTS controller will allow EXPLICIT and BIT_STROBE connections only

Network adjustable EPR_RATE timer: (default= 10sec for explicit connection, none for bit-strobe)

The EPR (Extendend packet rate) timer is set in 250msec increments. A value of less than 250 will keep the connection forever.

BIT_STROBE RETURN VALUES: (4 bytes returned)

BYTE 0: Status Code

| Value | Definition |
|-------|---|
| 0 | Off all mat |
| 1 | On at least one mat |
| 5 | Waiting for Fault Reset button to be pushed |
| 6 | Fault reset button held down |
| 10-19 | Mat fault codes |
| 21-26 | Relay fault codes |
| 27-32 | External relay fault codes |
| 34 | Ram failure |
| 35 | Power on reset |
| 36 | Clock / watchdog failure |
| 37 | Data exchange with Slave computer corrupted |
| 38 | Data exchange with Slave not completed |

Byte 1: Zone Status Definition(0=relays off / contacts open, 1=relays on / contacts closed)

| Bit 7 | Bit 6 | Bit 5 | Bit 4 | Bit 3 | Bit 2 | Bit 1 | Bit 0 |
|-------|-------|-------|-------|-------|---------|---------|---------|
| | | | | | Zone #3 | Zone #2 | Zone #1 |

Byte 2: Mat Status Definition(0=on mat, 1=off mat)

| Bit 7 | Bit 6 | Bit 5 | Bit 4 | Bit 3 | Bit 2 | Bit 1 | Bit 0 |
|--------|--------|--------|--------|--------|--------|--------|--------|
| Mat #8 | Mat #7 | Mat #6 | Mat #5 | Mat #4 | Mat #3 | Mat #2 | Mat #1 |

Byte 3: Options Enabled Definition (0=disabled, 1=enabled)

| Bit 7 | Bit 6 | Bit 5 | Bit 4 | Bit 3 | Bit 2 | Bit 1 | Bit 0 |
|----------|----------|----------|--------|--------|----------|-------------------------|------------------|
| Reserved | Reserved | Reserved | Aux #2 | Aux #1 | Mute-out | External relay checking | Manual resetting |

DISPLAY CODES & MESSAGES

| CODE | MESSAGE | Description | POSSIBLE CURE(S) |
|------|------------------------------------|---|---|
| | 42-015/016R14 42-021/022R15 | Occurs at power-up only | Metal box Din-rail |
| | OK OK U OK C OK A OK F | No options enabled DeviceNet unconnected (maybe unplugged from network) DeviceNet connected but not allocated (passed duplicated mac id check) DeviceNet allocated (in service) DeviceNet faulted out | - |
| | OkE | External relay checking enabled | - |
| | OkM | Manual reset enabled | - |
| 10 | Mat wiring fault | Check#1 for 47k resistor in mat, voltage coming back from mat below high setpoint | 1) Bad wiring 2) Bad comparator 3) Bad mat |
| 11 | Mat wiring fault | Low voltage on input that should be ground | " |
| 12 | Mat wiring fault | High voltage on input that should be ground | " |
| 13 | Circuit fault | Voltage out to mat below low setpoint | " |
| 14 | Circuit fault | Voltage out to mat below high setpoint | " |
| 15 | Circuit fault | One of the redundant circuits indicates ON mat, the other indicates OFF mat | " |
| 16 | Circuit fault | One of the redundant circuits indicates OFF mat, the other indicates ON mat | " |
| 17 | Circuit fault | High voltage on input that should be ground | " |
| 18 | Mat wiring fault | Low voltage on input that should be ground | " |
| 19 | Mat wiring fault | Check #2 for 47k resistor in mat, voltage coming back from mat below high setpoint | " |
| 20 | Zone # out of sequence | The master and slave processors disagree on which sequence they are on. | Could have an electrical noise problem causing one of the processors to loose sequence. |

DISPLAY CODES & MESSAGES (Continued)

| CODE | MESSAGE | POSSIBLE CAUSE(S) | POSSIBLE CURE(S) |
|----------|---|---|--|
| 21 | Zone 1 relay off, should be on | Relay found in the wrong state 1) Circuitry failure 2) Relay failure | Call for assistance |
| 22 | Zone 2 relay off, should be on | " | " |
| 23 | Zone 3 relay off, should be on | " | " |
| 24 | Zone 1 relay on, should be off | " | " |
| 25 | Zone 2 relay on, should be off | " | " |
| 26 | Zone 3 relay on, should be off | " | " |
| 27,29,31 | External relay contact welded / cut (Zone 1,2, or 3) | External relay check input remained open (0 volts) while the zone was de-energized | When the zone is de-energized (RED) your external relay must close with 1/4 sec. |
| 28,30,32 | External relay contact short (Zone 1,2, or 3) | External relay check input remained closed (voltage applied) while the zone was energized | When the zone is energized the secondary pole of your external relay (N.C.) must open up within 1/4 sec. |
| 33 | Mat # out of sequence | The master and slave processors disagree on which sequence they are on | Could have an electrical noise problem causing one of the processors to loose sequence |
| 34 | Ram failure | Microprocessor failed the internal memory test | Call for assistance |
| 35 | Power failure | 1) Circuitry failure 2) Brown out | Call for assistance |
| 36 | Watchdog failure | Watchdog circuitry failure | Call for assistance |
| 37 | Serial data corrupted | Electrical noise getting into the control box causing the corrupted data. | Place MOV's across the coil of any device (outside this control) switched on/off by the relay outputs of this controller |
| 38 | Serial data transmission incomplete | Electrical noise getting into the control box causing one of the computers to reset | " |
| 39 | Master relay on, Slave relay off | The master processor disagrees with the slave | Call for assistance |
| 40 | Slave relay on, Master relay off | The slave processor disagrees with the master | " |

SAFETY EVALUATION

Before releasing an installation for production, test the safety system on a daily basis or whenever a change or modification to the operation is made. Record and verify all tests and examinations.

- Check that the floor and environmental conditions are suitable for the device(s) in use.
- Check that the minimum safety distances are used in accordance to draft EN999 contained within this operation and installation manual. This is required for all installations going into the EC (European Community).
- Check that the pressure-sensitive mat or pressure-sensitive floor is fastened (fixed) securely in place and does not provide a trip hazard.
- Ensure that any "dead zones" do not provide an access path to the hazardous zone or area.
- Check that the removal of the power supply from the pressure-sensitive mat or pressure-sensitive floor prevents further operation of the machine. The machine should not be capable of being reactivated until power has been restored and the reset operated.
- Check that a hazardous movement or cycle is prevented while an actuating force is applied to the effective sensing area.
- Ensure that additional safeguards have been provided where necessary to prevent access to the dangerous parts of machinery from any direction not protected by the pressure sensitive mat or pressure sensitive floor.
- Check that the presence of a person between the danger zone and the sensor is prevented. If this is not possible, ensure that further safety measures are taken.
- Check that all indicator lamps/lights are functioning correctly.
- Check the sensitivity of the mat or floor over the whole effective sensing area.
- The adequate safety required for a machine depends on the safety integrity of the interface between the machine and its protective device(s). Where a category is stated by a "C" standard of a risk assessment, the checks should ensure the machine control circuits and the connections to the safety device(s) are in accordance with the interface connections agreed between the machine control manufacturer and the safety protective device manufacturer. Always meet or exceed OSHA, ANSI, and RIA safety standards.
- Where muting is provided, ensure that muting occurs only during the intended part of the machines' operation (e.g., during the cycle where no hazard exists). Refer to the applicable standard: OSHA CFR 1910.217, ANSI B11.1-2001, ANSI B11.19-2003, EN954-1, or the updated versions of these standards for the application.
- Do not release the subject machine for production unless all of the above items are met or exceeded.

MAINTENANCE

WARNING: Read the entire maintenance section of the manual before any maintenance is attempted.

The tasks which require definite technical knowledge or particular skills should be carried out exclusively by suitably-trained personnel.

Inspections of the STTS Safety Mat System™ should be conducted daily to assure that all mats in the guarded zone are working properly.

Cleaning of the mats with grease cutting soaps and water is permissible.

Refer to the Table of Contents for the proper section for fault displays, potential causes and cures, and possible remedies.

WARNING: Replace all perimeter trim pieces and screw anchors after maintenance. If the components are not correctly replaced and fitted properly, the requirements for the safety device may not be met.

WARNING: Only replacement parts approved by the manufacturer may be replaced by the user and that non-approved spares used with the safety device may not function to the designed requirements.

ANNEX A

MAT SIZING AND LAYOUT (from #prEN999)

The following formula is an international guideline for proper positioning and applications of safety mats for machine guarding. This formula must be followed for all safety mat applications supplied to the European Community (EC) member nations. CEN is the European Committee for Standardization. Final draft #prEN999.

The minimum distance from the danger zone shall be calculated by using the general formula:

$$S = (K \times T) + C$$

where:

- S** Is the safety mat minimum distance in inches/millimeters in a horizontal plane, from the danger zone to the detecting edge of the safety mat furthest from the danger zone.
- K** Is a parameter in inches/millimeters per second, derived from data on approach speeds of the body or parts of the body (K=63 inches/second or 1600mm/second).
- T** Is the total system stopping time performance (which includes activating the safety mat), the mat controller output signal switching device, and the time required to stop the machine and remove risk. **T = (Tm + Tc)**
- Tm** Total machine stopping time. Must be obtained by customer.
- Tc** The STTS safety mat system™ activation time including the controller is 19 msec/mat.
- C** Is an additional distance in inches/millimeters, based on intrusion towards the danger zone prior to actuation of the protective safety mat equipment. (C=48 inches or 1200 mm)

Examples of safety mat sizing calculations using inches and millimeters

| | | | | | | |
|----------|---|-------------------------|---|---|---|---------------------------------------|
| S | = | 63 inches/sec | x | T | + | 48 inches |
| Mat Size | | Body approach speed (K) | | Total Safety system stopping time in milliseconds | | Intrusion distance toward danger zone |
| S | = | 1600 mm/sec | x | T | + | 1200 mm |

ANNEX B (informative)

Walking speeds and stride lengths

The positioning of equipment, which is activated by a person walking into the detection zone by stepping onto a pressure-sensitive mat, is affected by speed of approach and stride length. The walking and stride lengths depend on the physical and anthropometric data of the population.

Speed of approach

This standard assumes that the approach of persons towards the danger zone will be at walking speed.

Stride length

Available research data has shown that the 95th percentile of two steps (i.e., starting and finishing with the same foot) measured from heel contact at walking speed is approximately 75 inches/1900 mm. By dividing by two and subtracting the 5th percentile shoe length this gives a stride length of 28 inches/700mm. If it is assumed that an allowance has to be made, for example, between the detection zone and the stride length of 2 inches/50 mm this gives a minimum width of 30 inches/750 mm for the detection zone.

ANNEX C (Installation Practices for Industry)

The proper installation of the STTS Mat System is essential if the system is to operate properly. This section provides the user with general wiring, grounding, and shielding guidelines that should be followed in industrial installations.

These guidelines are presented as a tool in avoiding potential electromagnetic interference (EMI, also called Noise) problems. Because of the many ways that EMI problems can be generated, these guidelines are not meant as a cure-all, but instead as a list of basic rules that will help suppress or eliminate most common sources of EMI interference. These Guidelines are not a substitute for the safety practices called out in Local Electrical Codes or the National Electrical Code which is published by the National Fire Protection Association. If any discrepancies exist, the Local or National Codes must be followed. IT IS THE RESPONSIBILITY OF THE USER to determine what installation practices must be followed to conform to all National and Local Codes.

These Guidelines are organized into the following sections:

- 1) Raceway Layout (Wiring) Considerations
- 2) Grounding
- 3) Shielding of Cables

1.0) RACEWAY LAYOUT CONSIDERATIONS

1.1) RACEWAY PLANNING:

Before planning a raceway layout, all wires and cables in or around the controller and mat wiring should be broken into the following categories:

TYPE 1: High-Power Conductors

This category includes all high-power conductors. High power lines are usually quite tolerant of EMI noise problems but may also generate large amounts of EMI noise that may disturb other conductors near them. These conductors include:

- 1) High-Power AC and DC Lines
This includes all power lines to and from mechanical switches, relays, solenoids, motors, generators, arc welders, etc.

TYPE 2: Low-Power Conductors

This category includes all low-power conductors. Low-power lines are usually less tolerant of EMI noise problems than Type 1 conductors but also generate less EMI noise. These conductors include:

- 1) STTS Mat Wiring Cables. This is the cabling that connects the safety mat to the controller.
- 2) Serial Communication Cables. These connect between processors and remote units such as displays, terminals, or other processors.
- 3) Low-Power AC/DC Switcher Lines. These lines include all lines that carry low currents and input circuits with short time-constant filters that are designed to detect short, single event pulses. Typically, these lines are connected to devices such as proximity switches, photo-electric sensors, and low power analog or digital devices.

TYPE 3: System Interconnect Cables

These cables interconnect the system components within an enclosure. They include:

- 1) ALL Ribbon Cables. This includes cables that interconnect system units or connect units to relay boards.

- 2) All other system interconnect Cables. This includes serial interface cables, transducer cables, and unit power cables.

1.2) RACEWAY LAYOUT GUIDELINES

Once the cables of the system have been classified, the following suggestions should be followed when possible to guard against coupling noise from one conductor to another in a raceway. These guidelines apply to cable routing both inside and outside the enclosure.

- 1) All Type – 1 conductors should be routed in a separate raceway from Type 2 and 3 conductors. Type – 1 conductors may be routed with machine power conductors of up to 600VAC , if it is done in accordance with all safety codes. The raceway must be well grounded along its entire length.
- 2) All Type – 2 conductors must be properly shielded by conduit or bonded sealtite, where applicable, and routed in a separate raceway. The raceway must be well grounded along its entire length.
- 3) Route Type – 2 conductor raceways at least 1 ft (30 cm) from 120VAC Type – 1 conductor raceways, 2 ft. (60 cm) from 240 VAC Type – 1 conductor raceways, and 3 ft. (100 cm) from 480 VAC Type – 1 conductor raceways when ever possible.
- 4) Route Type – 2 conductors at least 3 ft. (100 cm) from any high power electric device such as motors, generators, transformers, etc. whenever possible.
- 5) If a Type – 2 conductor raceway must cross Type – 1 conductor raceway, it should do so at right angles to the Type – 1 raceway.
- 6) All Type – 3 conductors should be routed external to all raceways or, preferable, in a raceway separate from any Type – 1 or Type – 2 conductor raceways.

2.0) GROUNDING GUIDELINES

After the raceway layout has been established, the mounting of the components in the system and the proper grounding should be done.

Proper grounding is important for safety reasons in electrical installations. With solid-state controls, such as the STTS Mat Controller, proper grounding procedures (including the elimination of ground loops) has the added advantage of reducing the effects of EMI interference. A proper grounding path must be permanent and continuous and must be able to safely conduct all ground-fault currents to earth ground with a minimum impedance.

2.1) SHIELDED CABLES

Certain connections such as the safety mat wiring require conduit or bonded sealtite cables to help reduce the effects of induced EMI noise from other conductors. **It is imperative that the shield is grounded, but only at one end.**

The shield should be grounded at the point that the signal is generated. For example, a transducer cable should be grounded at the controller because it is the controller that generates the signals that operate the transducer. If a shield is not grounded, the shield will act as an antenna and will actually help induce the unwanted EMI noise into the cable! However, if the shield is grounded at both ends of the cable, there is a potential of a ground loop will be formed that could cause faulty system operation.

If a cable must be spliced somewhere along its length, the splice must be made in **Grounded Metal Enclosure**. The drain wires of the shielded pairs **MUST** be connected to ensure that the cable is shielded along its entire length. However, the shields and drain wires of the cable must be isolated from the enclosure to prevent the possibility of a ground loop.

ANNEX D (Replacement Part Listing)

Mat Wiring

| Part # | Description |
|---------------|-----------------------------|
| E120 | 20' Nano to Nano Extension |
| E210 | 10' Nano to Wire Extension |
| E215 | 15' Nano to Wire Extension |
| E220 | 20' Nano to Wire Extension |
| E225 | 25' Nano to Wire Extension |
| E250 | 50' Nano to Wire Extension |
| E310 | 10' Nano to Micro Extension |
| E315 | 15' Nano to Micro Extension |
| E320 | 20' Nano to Micro Extension |
| E325 | 25' Nano to Micro Extension |

Nano is the descriptive plug size of the plug on a “P” or “R” style mat.

Wire Extension connects to a Nano plug on the mat with a hard wire end to either controller.

Micro Extension is a Nano plug on one end and a micro-sized connector on the opposite end that would connect to a receptacle mounted on the Metal Box Controller.

Perimeter Trim

| Part # | Description |
|---------------|--|
| M001 | Perimeter Trim—Includes M002 Built-In Wire Raceway |
| M001-M | Perimeter Trim—Includes M002 Built-In Wire Raceway |
| M001-M | Custom Trim Kits |
| M003 | Active Coupler |
| M005 | Surface Metal Raceway |

Replacement Mats

Reference part number and serial number for direct replacement

Replacement Relays

32-001

Screws

M011 #10 x 1 ¼” (31.75mm) stainless steel

Anchor

M012 #10 x 1” (25.4mm)

WARRANTY

Manufacturer warrants that this product will be free from defects in material and workmanship for a period of two years from the date of shipment thereof. Within the warranty period, manufacturer will repair or replace such products which are returned to it with shipping charges prepaid and which will be disclosed as defective upon examination by the manufacturer. This warranty will not apply to any product which will have been subject to misuse, negligence, accident, restriction, and use not in accordance with manufacturer's instructions or which will have been altered or repaired by persons other than the authorized agent or employees of the manufacturer.

DISCLAIMER

The provisions of the paragraph "Warranty" are the sole obligations of the manufacturer and exclude all other warranties of merchantability, expressed or implied. Further, there are no warranties, which extend beyond the above warranty.

LIMITATION OF LIABILITY

In the event of any claim or breach of any obligations of manufacturer under any order, whether expressed or implied, and particularly in the event of any claim or a breach of the warranty or warranties contained in the paragraph "Warranty" or of any other warranties, expressed or implied which might, despite the paragraph entitled "Disclaimer," be determined to be incorporated in any order, the company shall under no circumstances be liable for any consequential or special damages, either in law or in equity, or for losses or expenses or claims for the same arising from the use of, or inability to use, the products of the manufacturer for any purpose whatsoever.

WARNING: The entire machine safety system must be tested at the start of every shift. Machine testing should include: (1) proper machine operation and stopping capability; and (2) verification of proper installation and settings of all point of operation guards and devices before the operation is released for production.

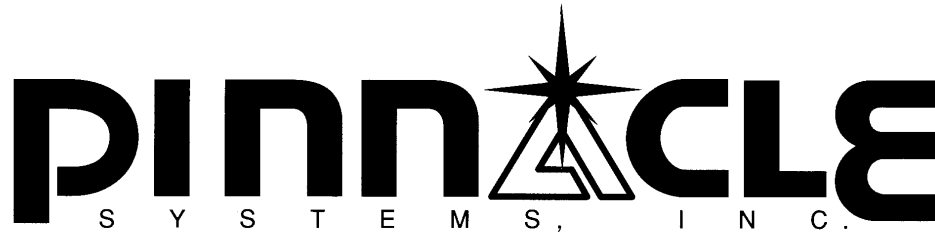

Sales and Marketing Offices

United States

Pinnacle Systems, Inc.
P.O. Box 100088
Pittsburgh, PA 15233
Toll Free Number: 800-569-7697
Direct Number: 412-262-3950
Fax: 412-262-4055

Canada

Pinnacle Systems, Inc.
8-1734 Orangebrook Court
Pickering, Ontario L1W 3G8
Toll Free Number: 888-285-8885
Direct Number: 905-831-1111
Fax: 905-831-4064

We have designed our equipment to the very highest performance and safety standards known to the current technological state of the art, as evidenced by our U.S.A. and foreign patents issued and pending. However, the installation, usage, suitability, and fitness of our equipment for any purpose, known or unknown, is interdependent upon the performance of other equipment not manufactured, installed, secured or maintained by Pinnacle Systems, Inc.

We cannot and do not accept responsibility for any overall system performance when factors, such as these, are beyond our control.

www.pinnaclesystems.com

sales@pinnaclesystems.com • service@pinnaclesystems.com