

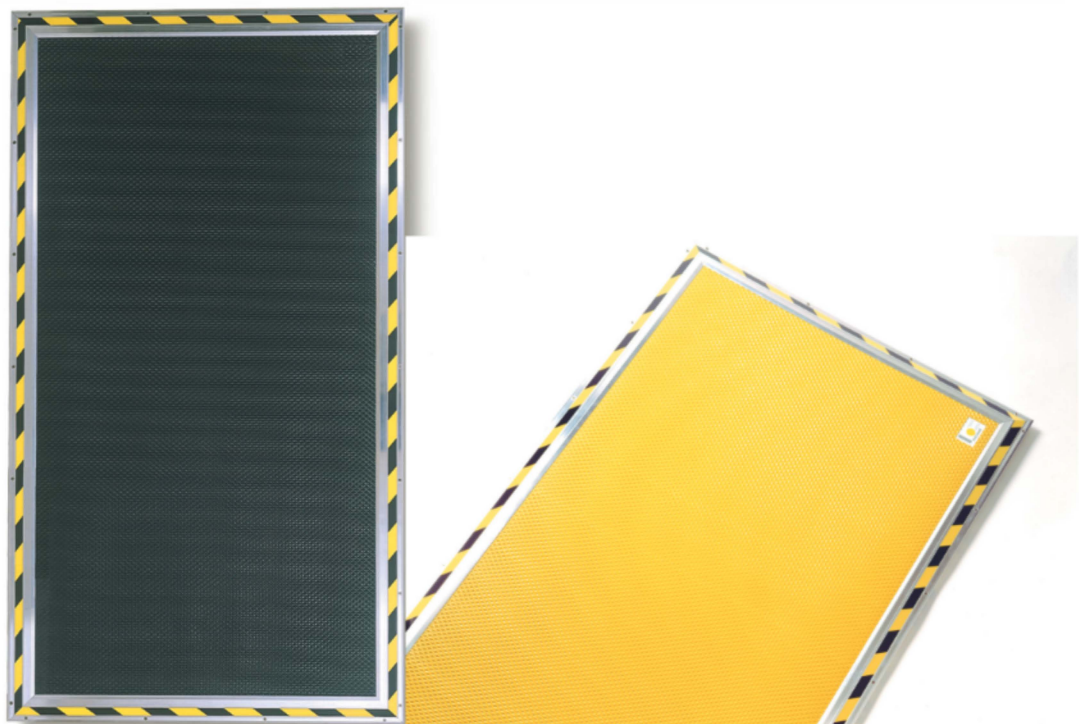

# **Safety Mat System Installation Instructions**

NOTE: This document provides instructions for mat installation only. Please reference the instructions provided by the controller manufacturer for controller installation.





# Mat Installation

**WARNING:** The entire machine safety system must be tested at the start of every shift. Machine testing should include: (1) proper machine operation and stopping capability; and (2) verification of proper installation and settings of all point of operation guards and devices before the operation is released for production.

The mat system has been designed to promote individual mat "homerun" wiring back to the mat controller. This is suggested for easing installation and diagnostics for maintenance troubleshooting. This will also eliminate cumbersome "daisy chain" wiring practices of mat systems. It also eliminates numerous wiring connection points buried under the perimeter trim which are time intensive to troubleshoot.

- 1) Sweep the floor area where the safety mat is to be installed. The floor should be flat and free of foreign material.
- 2) Locate the safety mat in the desired location. For future reference, install the mat with the label side up.
- 3) Slide the black wire raceway component under the mat edge (Part #M002). Refer to Figure 1 below for proper component positioning.

**NOTE:** The wire raceway component must be installed whenever the surface perimeter trim component is used.

- 4) Route the wire/plug assembly on the raceway toward the mat controller location.
- 5) Lay the aluminum perimeter trim piece around the mat assembly. Determine where the mat wiring will exit the trim and notch the trim and wire raceway for the wire to exit the assembly.
- 6) If surface metal raceway is used to route the wiring (Part #M005 or M006) from the mat assembly across the floor toward the mat controller, it should be aligned with the notch in the perimeter trim and anchored to the floor. Route wires accordingly and snap cover plate over the wires.
- 7) Slide the perimeter trim over the wire raceway component and align over the mat edge. Drill the perimeter trim and floor for securing the perimeter trim to the floor with anchoring screws and floor anchors.
- 8) If a multiple mat assembly is to be installed, use the aluminum active coupler component (Part #M003) to connect mats end to end or side to side. Refer to Figure 1 below.
- 9) Safety mats are to be fixed (anchored) in position.

**NOTE:**  
 Max voltage applied to mat: 24V (AC or DC)  
 Max current thru mat: 75mA  
 Mat resistance when Stepped on: 1K ohm

**Figure 1: Cross Section View of Mat Assembly Active Edging**

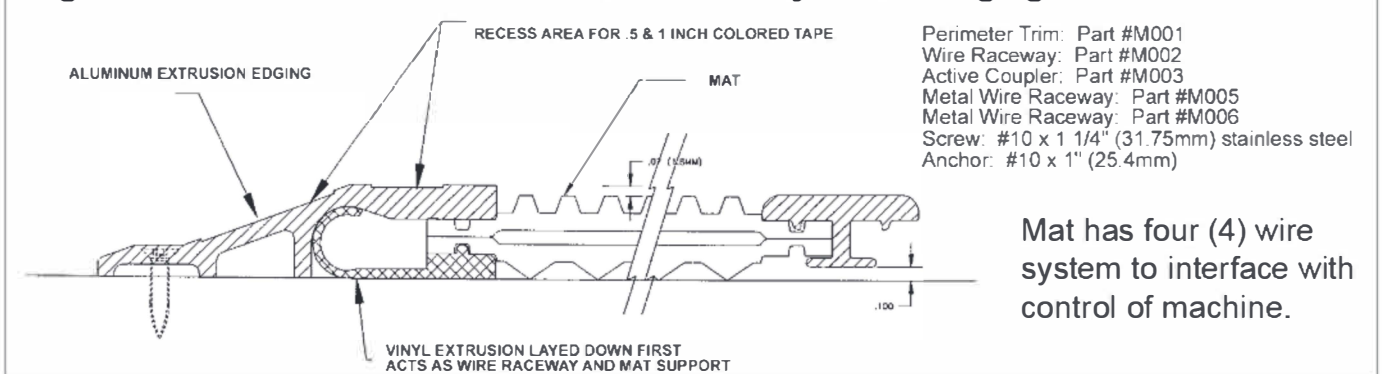

Mat has four (4) wire system to interface with control of machine.

## Chemical Resistance

The mat housing has excellent resistance to acids, alkalis, and salts. Hot acids and alkalis, as well as concentrated oxidizing and organic acids, have a deleterious affect over prolonged exposure.

### Mat Chemical Resistance

Water	E	Acetic Acid	F
Ethyl Alcohol	E	Gasoline	F
Sodium Chloride	E	ASTM 1 Oil	F
Bleach	E	Benzene	P
Hydrochloric Acid	F to E	Aceton	P
Sulfuric Acid	F to E	Trichlorethylene	P to F
Nitric Acid	F to E		

**Key:**  
 E=Excellent  
 F=Fair  
 P=Poor

## Sizing Your System

### How to Properly Size Your Safety Mat Guarding System

The following formula is an international draft guideline for the proper positioning and application of safety mats for machine guarding. This formula must be followed for all safety mat applications supplied to the European Community (CE) member nations. CEN is the European Committee for Standardization. Final draft #prEN999.

The minimum distance from the danger zone shall be calculated by using the general formula:

$$S = (K \times T) + C$$

**S** is the safety mat minimum distance in inches/millimeters in a horizontal plane, from the danger zone to the detecting edge of the safety mat furthest from the danger zone.

**K** is a parameter in inches/millimeters per second, derived from data on approach speeds of the body or parts of the body.  $K = 63$  inches/second or  $1600$  mm/second.

**T** is the total system stopping time performance, which includes activating the safety mat, the mat controller output signal switching device, and the time required to stop the machine and remove risk.

**C** is an additional distance in inches/millimeters, based on intrusion towards the danger zone prior to actuation of the protective safety mat equipment.  $C = 48$ " ( $1219$ mm).

### Annex B (informative)

#### Walking speeds and stride lengths.

The positioning of equipment which is activated by a person walking into the detection zone by stepping onto a pressure sensitive mat is affected by speed of approach and stride length. The walking speed and stride length depend on the physical and anthropometric data of the population.

**Speed of Approach.** This standard assumes the approach of persons towards the danger zone will be at walking speed.

**Stride Length.** Available research data has shown that the 95th percentile of two steps (i.e., starting and finishing with the same foot) measured from heel contact at walking speed is approximately  $7'$  ( $1905$ mm). By dividing by two and subtracting the 5th percentile shoe length provides a stride length of  $28'$  ( $711$ mm). If it is assumed that an allowance has to be made, for example, between the detection zone and the stride length of  $2'$  ( $50$ mm) this gives a minimum width of  $30'$  ( $762$  mm) for the detection zone.

## Examples of safety mat sizing calculations using inches and millimeters

<b>S</b>	=	<b>63"/sec</b>	x	<b>T</b>	+	<b>48"</b>
↑		↑		↑		↑
Mat Size	=	K Body approach speeds	x	Total safety system stopping time in milliseconds	+	Intrusion distance toward danger zone
↓		↓		↓		↓
<b>S</b>	=	<b>1600mm/sec</b>	x	<b>T</b>	+	<b>1219mm</b>

T-The Safety Mat System activation time including controller is 35 msec. This amount is to be added to the machine stopping time in milliseconds to fulfill the T requirement of the formula.





### **WARRANTY**

Manufacturer warrants that this product will be free from defects in material and workmanship for a period of one year from the date of shipment thereof. Within the warranty period, manufacturer will repair or replace such products which are returned to it with shipping charges prepaid and which will be disclosed as defective upon examination by the manufacturer. This warranty will not apply to any product which will have been subject to misuse, negligence, accident, restriction, and use not in accordance with manufacturer's instructions or which will have been altered or repaired by persons other than the authorized agent or employees of the manufacturer.

### **DISCLAIMER**

The provisions of the paragraph "Warranty" are the sole obligations of the manufacturer and exclude all other warranties of merchantability, expressed or implied.

Further, there are no warranties which extend beyond the above warranty

### **LIMITATION OF LIABILITY**

In the event of any claim or breach of any obligations of manufacturer under any order, whether expressed or implied, and particularly in the event of any claim or a breach of the warranty or warranties contained in the paragraph "Warranty" or of any other warranties, expressed or implied which might, despite the paragraph entitled "Disclaimer," be determined to be incorporated in any order, the company shall under no circumstances be liable for any consequential or special damages, either in law or in equity, or for losses or expenses or claims for the same arising from the use of, or inability to use, the products of the manufacturer for any purpose whatsoever.

**WARNING:** The entire machine safety system must be tested at the start of every shift. Machine testing should include:  
(1) proper machine operation and stopping capability; and  
(2) verification of proper installation and settings of all point of operation guards and devices before the operation is released for production.

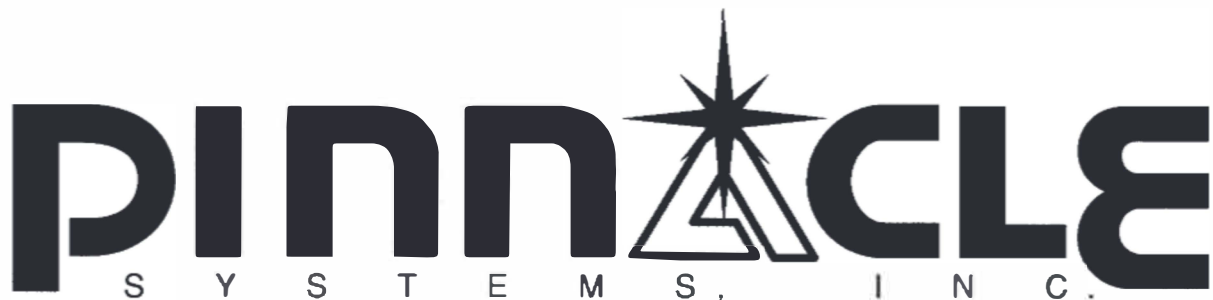

## Sales and Marketing Offices

### United States

Pinnacle Systems, Inc.

P.O. Box 100088

Pittsburgh, PA 15233

Toll Free Number: 800-569-7697

Direct Number: 412-262-3950

Fax: 412-262-4055

### United States

Pinnacle Systems, Inc.

1510 Hubbard Ave.

Batavia, IL 60510 USA

Direct Number: 630-443-8542

Fax: 630-443-8601

## Customer Service: (630) 443-8542

We have designed our equipment to the very highest performance and safety standards known to the current technological state of the art, as evidenced by our U.S.A. and foreign patents issued and pending. However, the installation, usage, suitability, and fitness of our equipment for any purpose, known or unknown, is interdependent upon the performance of other equipment not manufactured, installed, secured or maintained by Pinnacle Systems, Inc.

We cannot and do not accept responsibility for any overall system performance when factors, such as these, are beyond our control.

[www.pinnaclesystems.com](http://www.pinnaclesystems.com)

[sales@pinnaclesystems.com](mailto:sales@pinnaclesystems.com)  
[service@pinnaclesystems.com](mailto:service@pinnaclesystems.com)