

Models:

UL-101-2P (2 pole, 110VAC)

UL-101-4P (4 pole, 110VAC)

Installation

UltraTouch must be installed in pairs with an anti-tie down circuit between them to force the user to activate both units concurrently to initiate hazardous motion. Install units in such a manner that the wrist or forearm cannot activate both units while reaching into the point of operation. They shall be located a minimum of 25" apart, center to center. Install both units the proper distance away from the point of operation in accordance with OSHA regulations.

WARNING: Do not over-tighten the four hold down screws (diagram item #12). Tighten unit on top of gasket to obtain a snug fit and no more.

WARNING: This unit does not contain anti-tie-down circuitry. This function is performed either by a UL-601 unit or your own control system. This is an initiation device only and not a safety device.

Troubleshooting System

Red light, but no Green light when Hand inserted into channel:

- A) Excessive Sun or incandescent light over top the UL-101
- B) Conductive grease, or liquid in the channel
- C) Proximity of channel to nearby metal objects
- D) Did not wait 15 seconds at power-up
- E) Heavy gloves may require factory adjustment.

Operation

Each UltraTouch contains an optical sensor, capacitive sensor and circuitry that requires the user to activate both sensors within a 1/4 sec of each other. When you insert your hand into the slot, (1) you break the infrared beam, and (2) your mass is detected by the capacitive sensor (this dual sensor system prevents accidental activation of the unit due to shirt sleeves, etc.) The Green LED will light and the relay(s) will energize.

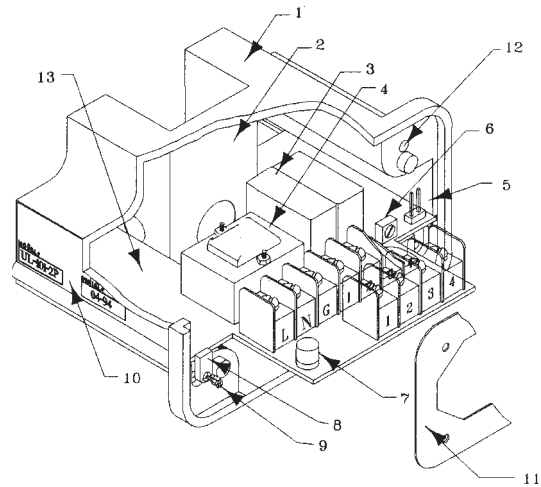

Item	Part No.	Description
1	11-057	IR plastic housing
2	21-024	Brass plate (cap. sensor)
3	32-001	Captive contact relay(s)
4	41-008	Transformer
7	20-022	1A fuse
8	11-022	Lock down tabs
9	22-008	#4 Phillips flat head screw
10	26-019	Identification label
11	21-008	Gasket
12	22-010	#6-32 x 5/8" Phillips screw
13	52-064	Entire sub-assembly

Terminal Description

L	110VAC line
N	Neutral
G	Earth Ground (required)
1 & 2	Open when green -- / --
3 & 4	Closed when green -- --
	Contacts rated at 2 amps @120VAC

**Second Relay & Terminal Strip:
Repeat of Terminals 1-4 (UL-101-4P)**

Standards:	UL: listed 42EL File SA11766 (UL508 & subject491) CSA: C22.2 142-M1987 IEC 60947-5-1 Dold Safety output relays UL,CSA,CE certified
IEC ratings:	Ue=120vac, Ui=600vac, Uimp=600vac Utilization: (A400) AC15 ,(N250) DC13 IP40 (when mounted with gasket) 1A slo-blow input protection no output protection
Temp:	Operating: 0°C to 55°C (32°F to 131°F) Storage: -40°C to 85°C (-40°F to 185°F)
Life:	Mechanical: 50,000,000 cycles Min Electrical: 200,000 cycles (replaceable safety relays)

Pinnacle Systems, Inc.

3715 Swenson Avenue • St. Charles, IL 60174

Customer Service: 630-443-8542 (CST)

(Please have Model, Serial, and Software Revision numbers available)

Sales and Marketing: 800-569-7697 (EST)

www.pinnaclesystems.com

sales@pinnaclesystems.com

service@pinnaclesystems.com

SAFETY DISTANCE FORMULA

Each operator hand control shall be located at a distance from the point of operation so that the operator cannot release either hand control and reach into the point of operation prior to die closure or prior to cessation of slide motion during the closing of the stroke.

Below is the formula for calculating the safety distance of the palm buttons:

The machine should be measured with the machine running at its fastest speed with its heaviest die or tooling and the stop time being measured at the 90° position in the down stroke. The following formula should be used when calculating the safety distance.

$$D_s = K \times (T_s + T_c + T_r + T_{bm})$$

D_s = Minimum safety distance between the device and the nearest point of operation hazard (in inches).

K = Hand speed constant. This value has been determined by various studies and although these studies indicate speeds of 63 in./sec. to over 100 in./sec., they are not conclusive determinations. The employer should determine this value by considering all factors, including physical ability of the operator.

T_s = Stop time of the machine tool measured at the final control element.

T_c = Response time of the control system.

T_s & T_c are usually measured by a stop time measurement device.

T_r = Response time of the presence sensing device and its interface, if any, as stated by the manufacturer or measured by the employer.

T_{bm} = Additional time allowed for the brake monitor to compensate for variations in normal stopping time.

Palm buttons used as operator hand controls must be installed in accordance with the installation instructions and applicable local regulations, such as OSHA, ANSI or European standards. The complete machine control system as well as the guarding systems must be considered, including interface, safety distance, ancillary guarding, and all control elements that affect safety. Consult with your local regulatory agency before installing the palm buttons.

WARNING: DO NOT use on full revolution power presses. This type of press cannot be stopped in mid-stroke.

