



Datasheet

NSD Safety Mat Controller Modules

Both Modules are compliant to OSHA & ANSI Standards - EN ISO 13849-1 EN 62061 EN 81-1 EN 50156-1



NSD-3580
24 VDC



NSD-3590
115 TO 230 VAC

Approvals



Technical data

General

ArticlePrice	udp_no_price
Function display	3 LED, green
Creepage distances and clearances between the circuits	EN 60664-1
Protection degree according to DIN EN 60529 (housing)	IP40
Protection degree according to DIN EN 60529 (terminals)	IP20
Ambient temperature min.	-25 °C
Ambient temperature max.	65 °C
Wire ranges screw terminals, fine-stranded / solid	1 x 0,14 mm ² - 2,5 mm ² / 2 x 0,14 mm ² - 0,75 mm ²
Wire ranges screw terminals, fine-stranded with ferrules	1 x 0,25 mm ² - 2,5 mm ² / 2 x 0,25 mm ² - 0,5 mm ²
Permissible torque min.	0.5 Nm
Permissible torque max.	0.6 Nm
Tightening moment	0.6 Nm
Wire range cage clamp terminals	2 x 0,25mm ² - 1,5mm ²
Weight	0.2 kg
Standards	EN ISO 13849-1 EN 62061 EN 81-1 EN 50156-1
Suited for safety functions	Yes
Category according to EN 954-1	4
Muting possible	No
Feedback circuit	Yes
Start contact	Yes
Performance level acc. to EN ISO 13849-1	e
Rail mounting possible	Yes

Connection Data

Detachable clamps	Yes
Type of electric connection	Screw connection

Application

Model	Basic device
Suitable for monitoring of magnetic switches	Yes
Suitable for monitoring of proximity switches	Yes

Suitable for monitoring of emergency-stop circuits	Yes
Suitable for monitoring of optoelectronic protection equipment	Yes
Suitable for monitoring of position switches	Yes

Output circuit

Enabling paths	3
Signaling paths	1
Contact material	Ag-alloy, gold-plated
Max. thermal current I _{th} , enabling paths	6 A
Max. thermal current I _{th} , signaling paths	2 A
Max. total current I ₂ of all current path	25 A ²
Application category AC-15 (NO)	Ue 230V, Ie 3A
Application category DC-13 (NO)	Ue 24V, Ie 5A
Short-circuit protection (NO), max. fuse insert	6 A class gG fuse, fuse integral < 100 A ² s
Mechanical life	107 switching cycles

Control circuit

Nominal output voltage DC	22.5 V
Input current (safety circuit / reset circuit)	25 mA
max. peak current (safety circuit / reset circuit)	100 mA
Response time t _{A1}	250 ms
Response time t _{A2}	250 ms
Min. switch-on time	60 ms
Recovery time t _W	120 ms
Release time t _R	20 ms
Synchronous time t _S	1.5 s
Permissible test pulse time t _{TP}	0.8 ms
max. resistivity, per channel	$\leq (5 + (1,176 \times U_B / U_N - 1) \times 100) \Omega$
Type of switch function of the inputs	Normally open contact
Evaluation inputs	2-channel

Supply circuit

Nominal voltage U _N	DC 24 V
Rated consumption DC	1.6 W
Operating voltage min.	22.4 V
Operating voltage max.	26.4 V

Dimensions

Depth	114 mm
Width	22.5 mm
Height	96.5 mm

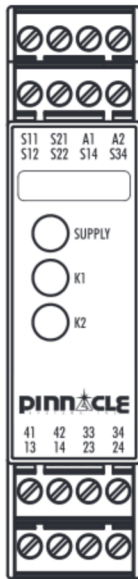

Basic device for Emergency Stop and Safety Mat applications

- Basic device according to EN 60204-1:2007 and EN ISO 13849-1:2007 for single or two-channel EMERGENCY STOP monitoring.
- PL e / category 4 according to EN ISO 13849-1:2007
- SILCL 3 according to DIN EN 62061:2005
- Stop category 0 according to DIN EN 60204-1
- Manual or automatic start
- With / without crossover detection
- Feedback circuit for monitoring external contactors
- Three enabling current paths, one messaging current path
- Evaluation unit for BWS 4 according to EN 61496-1
- Usage according to EN 81-1 and EN 50156-1
- For connection in series with a pressure sensitive mat according to EN 1760-1

Front View

- Supply LED green, power supply indicator
- K1, K2 LED green, operation and status indicator for relays K1 and K2



SAFETY REGULATIONS

- Installation, commissioning, modification and retrofitting must only be performed by a qualified electrician.
- Disconnect the device/the system from the power supply before starting work. In the case of installation and system errors, mains voltage can be present on the control circuit in the case of non-galvanically isolated devices.
- Observe the electrotechnical and professional trade association safety regulations for installation of the equipment.
- Opening the case or other manipulation voids any warranty.
- In the case of improper use or any use other than for the intended purpose, the device must no longer be used and any warranty claim is void. Invalidating causes can be: strong mechanical loading of the device, such as occur when falling or voltages, currents, temperatures, humidity outside the specifications.
- Always check all safety functions in accordance with the applicable regulations during initial commissioning of your machine/system and observe the specified inspection cycles for safety devices.



ATTENTION

- Take the following safety precautions before starting installation / assembly or dismantling:
 1. Disconnect the device / the system from the power supply before starting work.
 2. Secure the machine / system against being switched on again.
 3. Confirm that no voltage is present.
 4. Ground the phases and short to ground briefly.
 5. Cover and shield neighbouring live parts.
 6. The devices must be installed in a switch cabinet with a protection class of at least IP54.
- Limited contact protection! Protection class according to EN 60529:
 - Case/terminals: IP40/IP20.
 - Finger-proof according to EN 50247.

1 Proper use

The devices are safety switching devices. They must only be used as components of safety equipment on machines that is intended for the protection of persons, material, functions and machinery.

2 Function

The device is a two-channel safety switching device for EMERGENCY STOP equipment according to EN 60204-1. It performs self-monitoring during each ON-OFF cycle and is equipped with positively driven relays. The device is suitable for connection in series with short-circuiting pressure sensitive mats, pressure sensitive bumpers or switching edges with 4-wire technology (without a monitoring resistor).

Basic function: After applying the supply voltage to the terminals A1/A2 and closed safety inputs, the enabling current paths are closed when a valid reset signal is established at S34. The enabling current paths are opened when the safety inputs are opened/de-energised.

Operating modes / System functions

- Single-channel or two-channel actuation
- With or without crossover detection
- Manual start (triggering with falling edge)
- Automatic start
- Evaluation of signal transmitters featuring equivalent or non-equivalent switching



NOTE

- The performance level (PL) and safety category in accordance with EN ISO 13849-1 depend on the external wiring, the application case, the choice of control device and how this is physically arranged on the machine.
- The user must carry out a risk assessment in accordance with ISO 14121-1.
- The entire system/machine must undergo validation in accordance with the applicable standards on the basis of this.
- The stated performance level will only be achieved if, taking into account the prevailing device load (see EN ISO 13849-1 Table C.1) and the application case, an average number of switching cycles per year is not exceeded (see EN ISO 13849-1, C.2.3 and Table K.1). Assuming that the B10d value is 400,000 for the maximum load, the maximum cycle number would be $400,000 / 0.1 \times 30 = 133,333$ switching cycles per year.
- The safety-related characteristics only apply when the relays are switched at least once per year.
- Operating the device other than specified can result in malfunctions or destruction of the device.
- The device must be checked to ensure it is in perfect working order before commissioning, after replacement of modules and/or in the case of changes to an installation that has already undergone acceptance.
- For operation at 115–230 VAC, the operating equipment of the control circuits must be designed for a rated voltage of 300 V. Basic isolation between supply and control circuits.
- The specified times must always be adhered to when operating the device; otherwise, the device may become locked. Locking may be reversed by opening the safety

NOTE

inputs in the proper manner.

- The expansion units of the SNE series or external contactors with positively-driven contacts can be used for duplicating the enabling current paths
- The contacts must be fused with maximum 6 A operating class gG.
- Control outputs S11 and S21 are equipped with overload protection (for short circuits). Once the cause of the error has been rectified, the device is ready for operation again after approx. 3 s.
- The control inputs and outputs are only used for the connection of control devices and not for the connection of external consumers such as lamps, relays or contactors.
- External loads must be equipped with a suitable protection circuit for the load (e.g. RC elements, varistors, suppressors, etc.) in order to reduce electromagnetic interference and increase the service life of the output switching elements.
- The application-specific standards must be observed when installing and operating the device.
- The safety functions have not been checked by UL. The certification process has been carried out in accordance with the requirements for general applications as stipulated by UL508.

3 Mounting

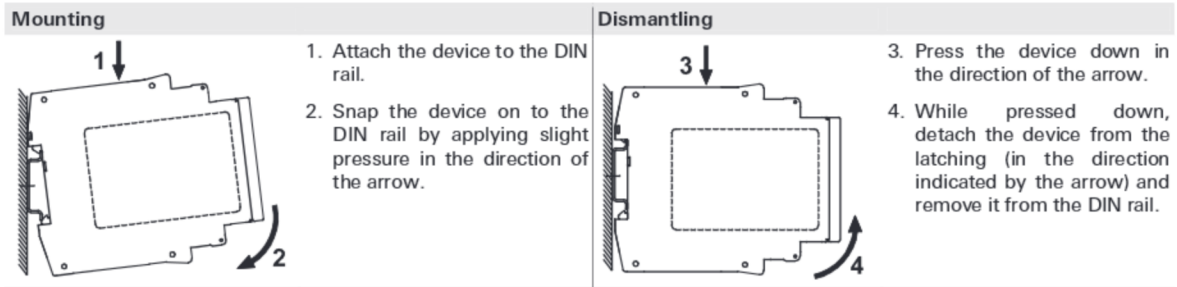

4 Terminal diagram

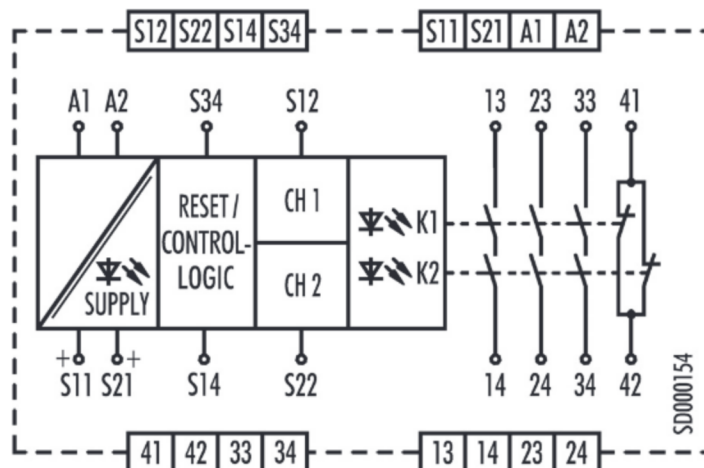

5 Function diagrams

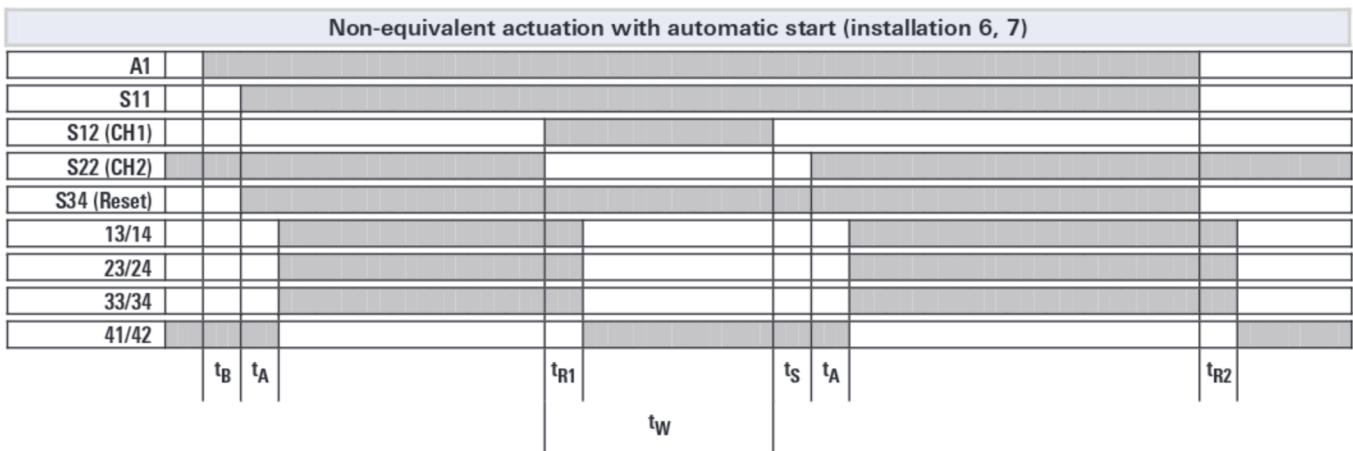
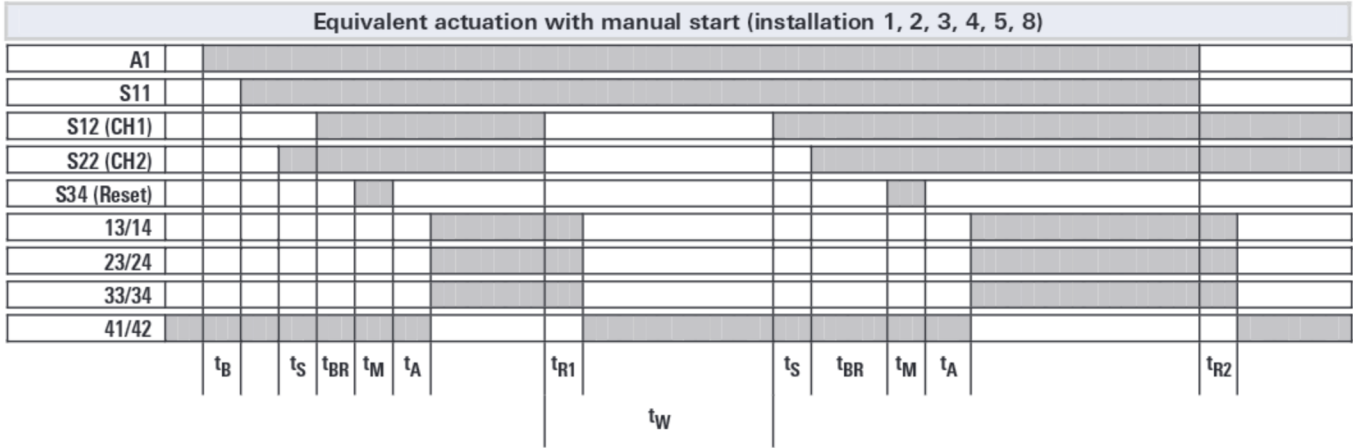

6 Installation

1 – EMERGENCY STOP button, single-channel

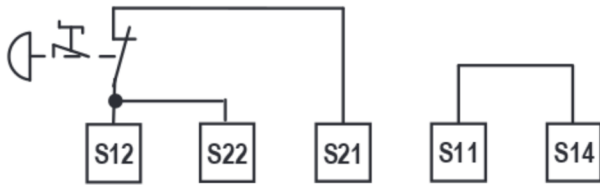

2 – EMERGENCY STOP button, two-channel without crossover detection

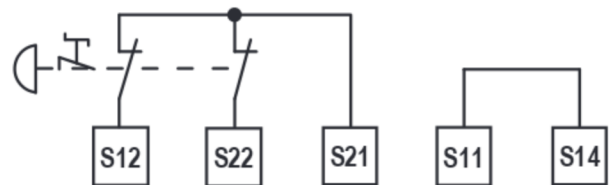

3 – Safety light curtain BWS type 4, two-channel with crossover detection by BWS¹⁾

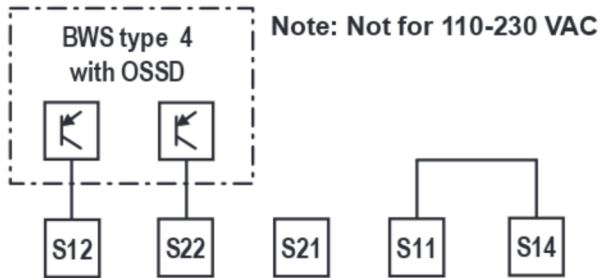

4 – EMERGENCY STOP button, two-channel with crossover detection

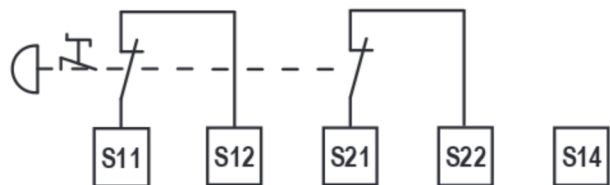

5 – Pressure sensitive mat, two-channel with crossover detection

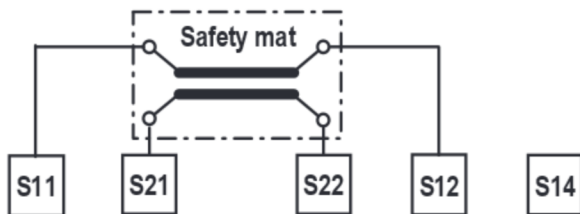

6 – Solenoid switch, two-channel, non-equivalent, with crossover detection

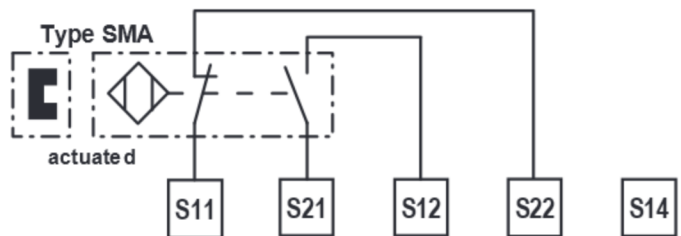

7 – Reset, automatic, with and without feedback circuit

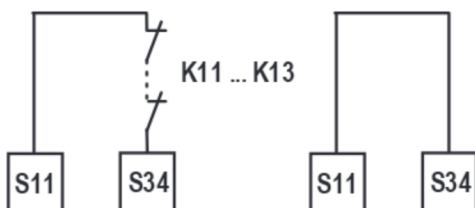

8 – Reset, manual, monitored, with and without feedback circuit

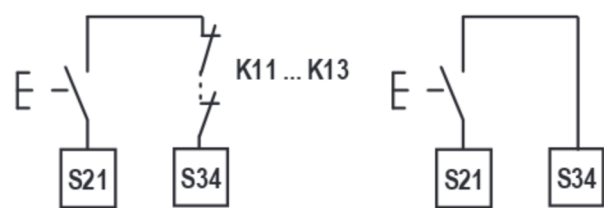

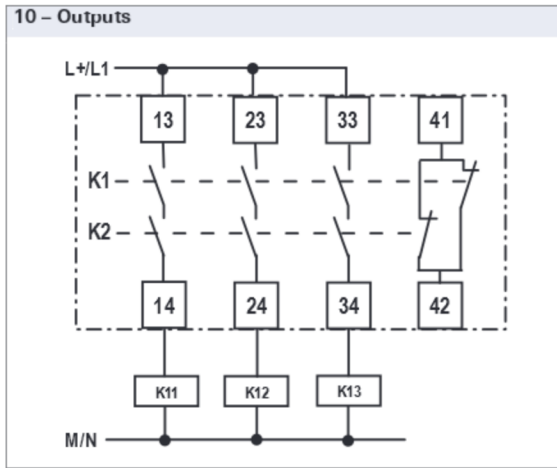
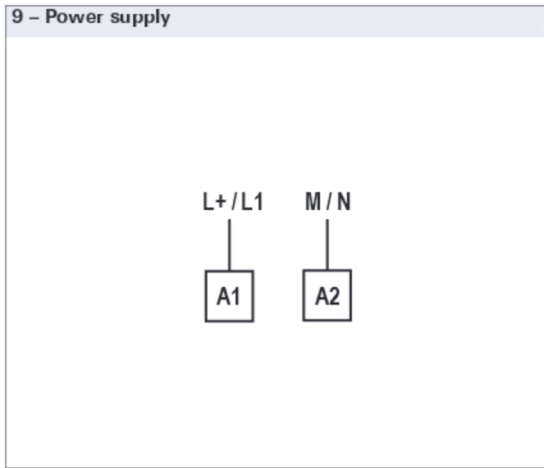

7 Contact load derating

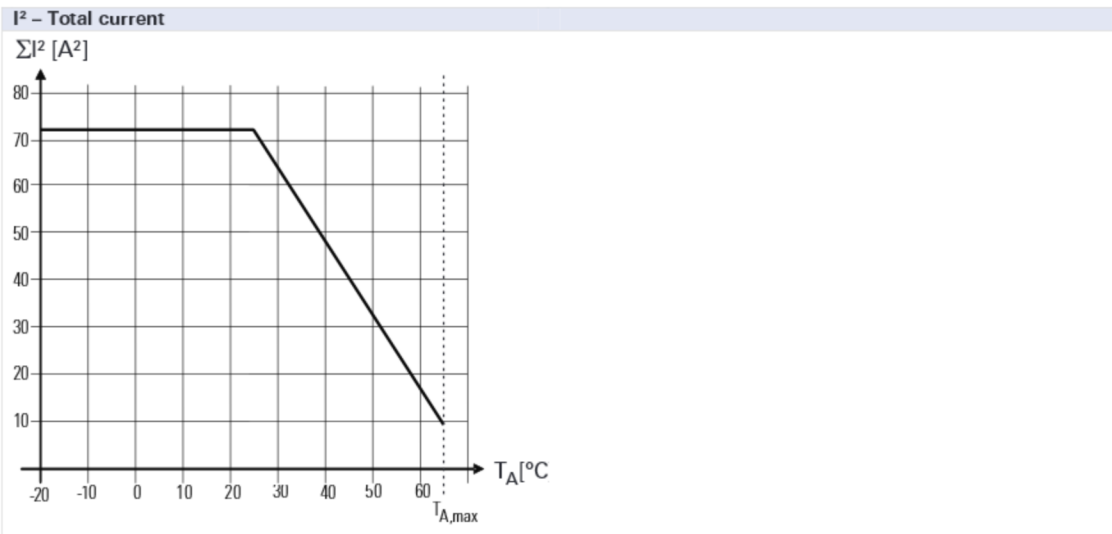

8 Relay service life

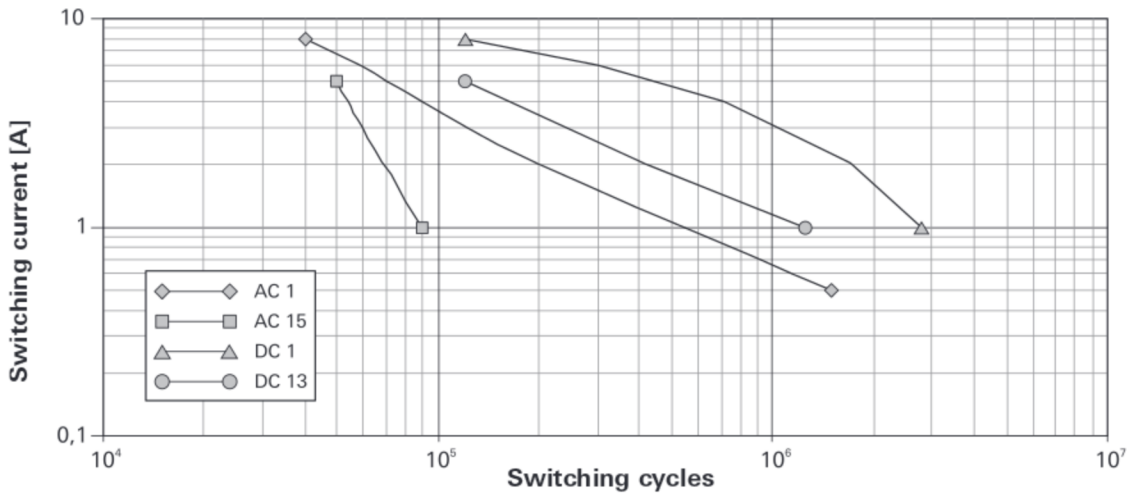

9 Dimensions

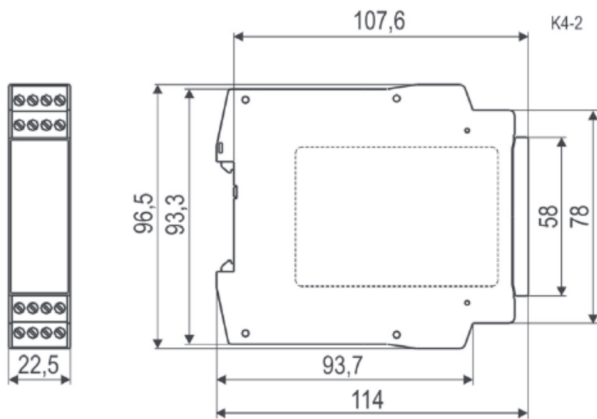

10 Technical data

NSD-3580 24 VDC

NSD-3590 115 TO 230 VAC

Function	EMERGENCY STOP relay		
Function indicator	3 LEDs, green		
Power circuit			
Rated voltage U_N	24 V DC	115–230 VAC	
Operating voltage range U_B : $0.85\text{--}1.1 \times U_N$	20.4 to 26.4 VDC	97 to 253 VAC	
Rated power	1.6 W	1.8 W / 4.0 VA	
Nominal frequency		50-60 Hz	
Electrical isolation between supply and control circuits		Yes	
Control circuits	S11/S21	S12/S22	S14/S34
Rated output voltage	22.5 V DC		
Input current		25 mA	3 mA
Max. peak current		100 mA	5 mA
Response time (manual start t_{A1} , autom. start t_{A2})	250 ms		
Minimum activation time t_M (manual start)	125 ms		
Recovery time t_W	120 ms		
Release time t_R	20 ms		
Synchronous time monitoring t_S	0.5 s / 1.5 s		
Test pulse length t_T	4 ms		
Test pulse interval T_{TEST}	200 ms		
Permissible test pulse time t_{TP}	< 0.8 ms		
Test pulse length t_{TR} of the incoming test pulse	< 16 ms		
Delay time t_D (time between test pulse and incoming test pulse)	< 48 ms		
Max. line resistance per channel ²⁾	24 VDC 115–230 VAC	$(5 + (1.176 \times U_B / U_N - 1) \times 100) \Omega$ 12 Ω	
Output circuits	Enabling current paths 13/14, 23/24, 33/34		Messaging current paths 41/42
Contact	Normally open		Normally closed
Contact type	Positively driven		
Contact material	Ag alloy, gold plated		
Rated switching voltage U	230 VAC		
Max. thermal permanent current I_{TH}	6 A		2 A
Max. total current I_N^2	55°C 65°C	25 A ² 9 A ²	
Utilisation category	AC-15 DC-13	U_o 230 V, I_o 5 A U_o 24 V, I_o 5 A	
Short circuit protection	6 A class gG fuse, fuse integral < 100 A ² s		
Mechanical service life	10 ⁷ switching cycles		

Terminals and connection data	Screw terminals	Spring-loaded terminals
Single-core or finely stranded	1 × 0.14–2.5 mm ² 2 × 0.14–0.75 mm ²	2 × 0.2–1.5 mm ²
Finely stranded with wire-end ferrule according to DIN 46228	1 × 0.25–2.5 mm ² 2 × 0.25–0.5 mm ²	2 × 0.25–1.5 mm ² (trapezoid crimping)
AWG conductor size (only use Cu wires)	26–14	24–16
Maximum tightening torque	0.5–0.6 Nm (5–7 lbf-in)	
Stripping length	Max. 8 mm	
General data		
Air gap and creepage paths between the circuits	EN 60664-1	
Protection class according to EN 60529 case/terminals	IP40/IP20	
Ambient operating temperature	–25 to +65 °C	
Storage temperature	–25 to +75 °C	
Weight	0.2 kg	
Standards	EN ISO 13849-1, EN 62061, EN 81-1, EN 50156-1	
Certifications	TUV, cULus (in progress)	

11 Error codes and correction

Flashing code	
2	Crossover, can be rectified during operation
3	Process error, failure to observe the correct sequence for two-channel actuation, can be rectified during operation by repeating the actuation sequence correctly
4	Synchronous time error, synchronous time exceeded in the case of two-channel actuation, can be rectified during operation by adhering to the synchronous time
5	Maximum reset actuating time exceeded, can be rectified during operation by repeating the reset with the correct time
6	Configuration error, can be rectified by ensuring the correct terminal assignment for the required configuration, the device has to be switched off and on again
7	Permissible input voltage limits undershot/overshot S12 and S22, can be rectified by setting the supply voltage correctly, the device has to be switched off and on again
8	Device temperature too high, can be rectified by reducing the contact loads or the ambient temperature, the device has to be switched off and on again
≥ 12	Internal monitoring event, please replace the device and contact after sales service
If an error is still indicated even after the cause has been rectified, inputs S12, S22, S14 and S34 must be kept open during power-on (e.g. pull out the connector). The error should then be cleared and you can perform a restart with the required installation by means of a power-off and power-on operation.	